



**MASTER COPY**  
**DO NOT DESTROY**

Publication: 203047

Issue Date: January 1989

## **TECHNICAL MANUAL**

### **Transmitting Antenna Coupler**

**Model TRC-5K**

**(TRC-5000)**

**The Technical Materiel Corporation**  
700 Fenimore Road  
Mamaroneck, New York 10543-0142 U.S.A.



**Publication: 203047**

**Issue Date: January 1989**

**TECHNICAL MANUAL**

**Transmitting Antenna Coupler**

**Model TRC-5K**

**(TRC-5000)**

**THE TECHNICAL MATERIEL CORP RATION**

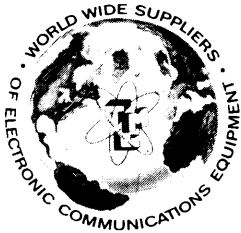

## Warranty

The Technical Materiel Corporation, hereinafter referred to as TMC, warrants the equipment - except electron tubes, semi-conductor devices, fuses, lamps, batteries, and articles made of glass or other fragile or expendable materials - purchased hereunder to be free from defect in workmanship and materials under normal use and service, when used for the purposes for which the same is designed, for a period of ONE YEAR from the date of delivery FOB factory. TMC further warrants that the equipment will perform in a manner equal to or better than published technical specifications as amended by any additions or corrections thereto accompanying the formal equipment offer.

TMC will replace or repair any such defective items, FOB factory, which may fail within the stated warranty period, provided:

- Any claim of defect under this warranty is made within sixty (60) days after discovery thereof and that inspection by TMC, if required, indicates the validity of such claim to TMC's satisfaction;
- The defect is not the result of damage incurred in shipment from or to the factory;
- The equipment has not been altered in any way either as to design or use whether by replacement parts not supplied or approved by TMC, or otherwise; and
- Any equipment or accessories furnished but not manufactured by TMC, or not of TMC design shall be subject only to such adjustments as TMC may obtain from the supplier thereof.

At TMC's option, any defective part or equipment which fails within the warranty period shall be returned to TMC's factory for inspection, properly packed with shipping charges prepaid and the TMC RETURN AUTHORIZATION number clearly marked on the package. Electron tube warranty claims should be made directly to the manufacturer of such tubes since tubes furnished by TMC bear only the manufacturer's warranty.

No warranties, expressed or implied, other than those specifically set forth herein shall be applicable to any equipment manufactured or furnished by TMC and the foregoing warranty shall constitute the purchaser's sole right and remedy. In no event does TMC assume any liability for consequential damages, or for loss, damage or expense directly or indirectly arising from the use of such equipment, or any inability to use them either separately or in combination with other equipment or materials or from any other cause.

All inquiries should be directed to the following:

### **THE TECHNICAL MATERIEL CORPORATION**

Customer Service  
700 Fenimore Road  
Mamaroneck, New York 10543 U.S.A.

Telephone 914-698-4800  
Facsimile (FAX) 914-698-4805  
Telex 137-358 TECHMAT MECK

**THE TECHNICAL MATERIEL CORPORATION**

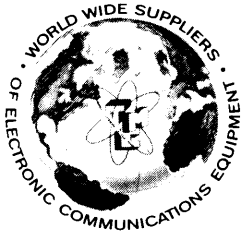

**THE CONTENTS AND INFORMATION CONTAINED IN THIS INSTRUCTION MANUAL IS PROPRIETARY TO THE TECHNICAL MATERIEL CORPORATION TO BE USED AS A GUIDE TO THE OPERATION AND MAINTENANCE OF THE EQUIPMENT FOR WHICH THE MANUAL IS ISSUED AND MAY NOT BE DUPLICATED EITHER IN WHOLE OR IN PART BY ANY MEANS WHATSOEVER WITHOUT THE WRITTEN CONSENT OF THE TECHNICAL MATERIEL CORPORATION.**

## **RECORD OF REVISIONS**

REVISION 01
REVISION 02
REVISION 03
REVISION 04
REVISION 05
REVISION 06
REVISION 07
REVISION 08



## Table of Contents

---

<b>Section 1</b>	<b>General Description</b>
1.1	Functional Description
1.2	Physical Description
1.3	Technical Specifications
1.4	TRC Product Group
<b>Section 2</b>	<b>Installation</b>
2.1	Initial Inspection
2.2	Electrical Installation
2.3	Performance Check
<b>Section 3</b>	<b>Operation</b>
3.1	General
<b>Section 4</b>	<b>Maintenance</b>
4.1	General
4.2	Preventive Maintenance
4.3	Troubleshooting
4.4	Repair
<b>Section 5</b>	<b>Parts Lists</b>

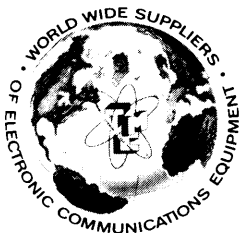

---

## List of Illustrations

Overleaf	Photographic prints of TRC-5K and TRC-20K couplers
Figure 2.1	Schematic Diagram, Typical Rhombic Antenna System
Figure 2.2	Outline Drawing with Mounting Dimensions
Figure 5.1	Cutaway View, Model TRC-5K

---

## List of Tables

Table 2.1	Loose Items Supplied
Table 5.1	Replacement Spare Parts List

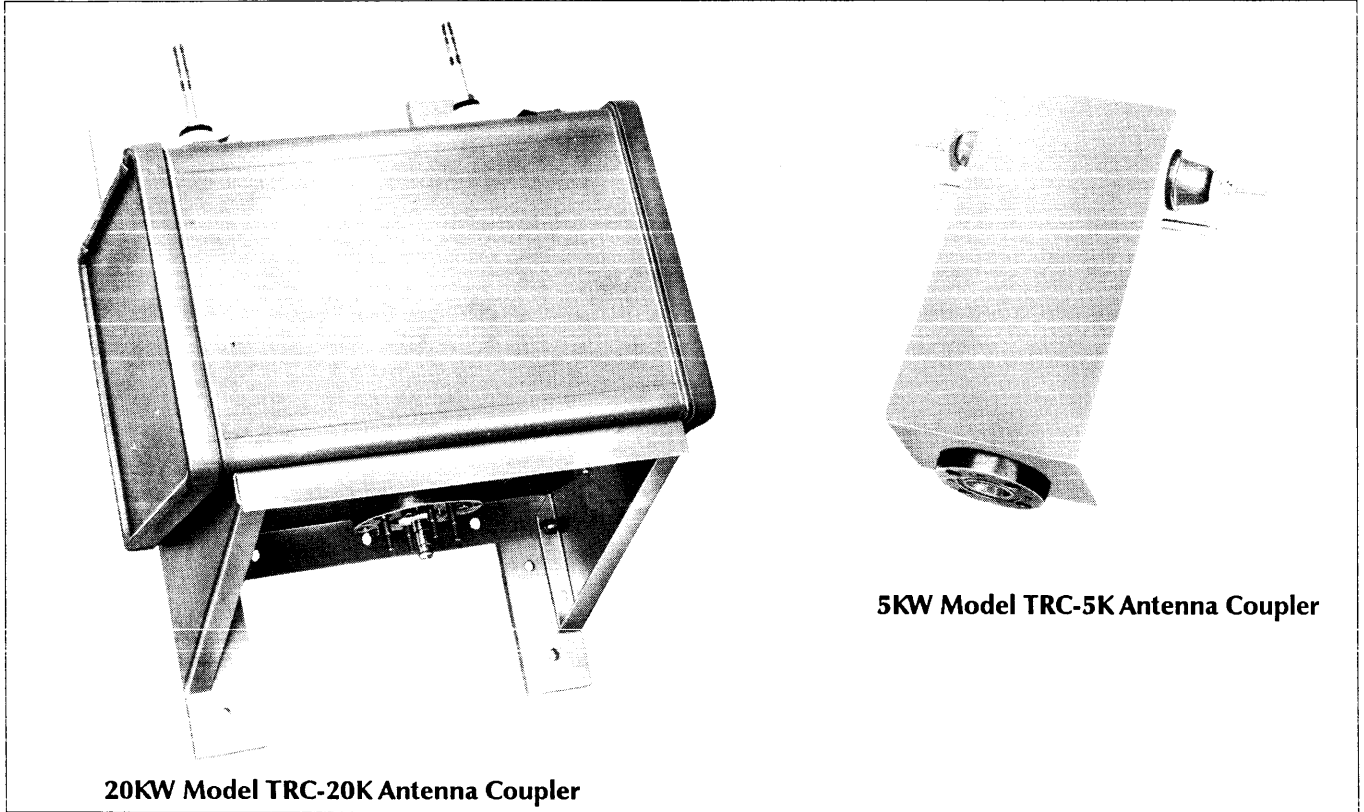

**20KW Model TRC-20K Antenna Coupler**

**5KW Model TRC-5K Antenna Coupler**

The designation "TRC" is used herein to refer interchangeably to the TRC-5K and TRC-5000.

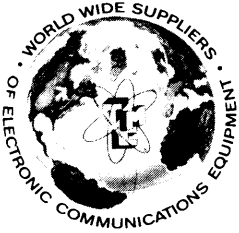

## Section 1 - General Description

---

### 1.1 Functional Description

#### 1.1.1 Overview

The TRC-5K HF Transmitting Antenna Coupler is a broadband transformer coupling unit used for matching coaxial transmission lines to rhombic or other antenna systems requiring a 600-ohm impedance. Use of the TRC-5K at a transmitting facility will allow uniform coaxial transmission and coaxial antenna transfer by providing the proper impedance match at the transmitting antenna. The TRC-5K provides an efficient means of coupling to match RF impedances at power levels of 5,000 watts average or 10,000 watts PEP over the frequency range of 2 to 28MHz. It provides an insertion loss less than 1dB over this range.

#### 1.1.2 Major Assemblies

The TRC coupler consists of one broadband transformer housed in a re-inforced fiberglass case for operation in any ambient environment from -50°C to +75°C. Spark gaps provide protection against static electricity on the antenna as well as lightning discharge. Mounts are provided for either pole or wall mounting. Since no maintenance is required, the coupler may be placed in any isolated area, such as an antenna farm. Outline and mounting dimensions of the TRC-5K are shown in Figure 2.2.

#### 1.1.3 Input/Output Characteristics

Two basic models of the TRC-5K are available: a 50-ohm version used to match a 50-ohm unbalanced impedance to a 600-ohm balanced impedance and a 70-ohm version used to match a 70-ohm unbalanced impedance to a 600-ohm balanced impedance. The models are differentiated by an option number added to the TRC-5K designation. These options, listed in Section 1.4, reflect the type of unbalanced connector assembly used.

### 1.2 Physical Description

#### 1.2.1 Equipment Mounting

The TRC-5K is designed for either pole or wall mounting. Two mounting straps with the necessary lag bolts are provided for pole mounting while wall mounting uses four mounting brackets fastened directly to the TRC case.

#### 1.2.2 Balanced RF Connections

The balanced connectors consist of two Mycroy<sup>R</sup> bowls mounted to opposite sides of the coupler case. Standard threaded rods with stainless steel nuts and flat washers are used to secure the antenna feed lines.

#### 1.2.3 Unbalanced RF Connections

Several unbalanced connectors are available for the TRC units and are mounted at the bottom of the TRC case. Although a standard 1-5/8 inch EIA flange assembly is normally provided, different choices are available depending on the antenna installation. Refer to Section 1.4 or the IMC Connector Products Catalog for other connector assemblies.



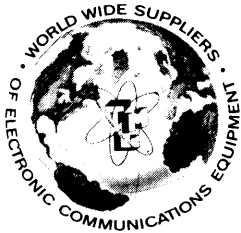

### 1.3

## Technical Specifications

### Frequency Range

2 - 28 MHz

### Insertion Loss

Less than 1dB over operating range.

### RF Power Rating

10KW PEP/5KW Average. 15KW PEP under a 20% duty cycle.

### Impedance Matching Capability

For 50-ohm operation: 50 ohms unbalanced to 600 ohms balanced.

For 70-ohm operation: 70 ohms unbalanced to 600 ohms balanced.

### RF Fittings - Unbalanced Coaxial

1-5/8 inch EIA Flange standard. Optional RG85/U, QDL or LC type assemblies with others available depending on application. (See chart Section 1.4)

### RF Fittings - Balanced Bowls

Twin Mycroy<sup>R</sup> bowls on 12-inch centers.

### Mean-Time-Between-Failure

In excess of 100,000 hours.

## Operating Features

### Cooling

Convection, no fans or moving parts

### Ambient Conditions

-50°C to +50°C; Up to 100% R.H. Storage -50°C to +80°C

### Primary Power

Passive device. No external power is required.

### Size and Weight

8W x 5D x 14H inches, 20lbs (20.3W x 12.7D x 35.6H cm, 9.1Kg)

Shipping cube approximately 2 cu.ft. Shipping weight approximately 32 lbs.

### Mounting

Crossbar with heavy-duty straps.

## Special Features

### Safety

External spark gap for protection against static charges and lightning.

### Components and Construction

Totally solid state transformer assembly, mounted internally to a reinforced fiberglass case that is sealed for protection against the environment. External hardware is stainless steel.



**1.4**

**TRC Product Group**

- TRC-500**      **HF Transmitting Antenna Coupler, 500W**
- TRC-3.5K**    **HF Transmitting Antenna Coupler, 3.5KW**
- TRC-5K**      **HF Transmitting Antenna Coupler, 5KW**
- TRC-20K**     **HF Transmitting Antenna Coupler, 20KW**

**Unbalanced Connector Assembly Options:**

	<b>Operation:</b>	<b>50-ohm</b>	<b>70-ohm</b>
● BN connector	(Note 1)	/283-1	/283-3
● BNC connector	(Note 1)	/284-1	/284-3
● C connector	(Note 1)	/286-1	/286-3
● HN connector	(Note 1)	/285-1	/285-3
● N connector	(Note 1)	/259-1	/259-3
● QDS connector	(Note 1)	/289-1	/289-3
● 1-5/8 inch EIA flange	(Note 2)	/272-1	/271-1
● LC -type connector	(Note 3)	/287-1	/287-5
● QDL-type connector	(Note 3)	/273-1	/273-3
● 3-1/8 inch EIA flange	(Note 4)	/501	/701
● 3-1/8 to 1-5/8 adapter	(Note 4)	/278	/279
● RG85/U mounting flange	(Note 5)	/274-1	/274-3
● No connector assembly		/500	/700

- Note 1      Model TRC-500 only.
- Note 2      Models TRC-3.5K and TRC-5K
- Note 3      Models TRC-500, TRC-3.5K and TRC-5K
- Note 4      Model TRC-20K only.
- Note 5      Model TRC-5K only.

**To order, specify both model and option. Example: TRC-5K/272-1.**

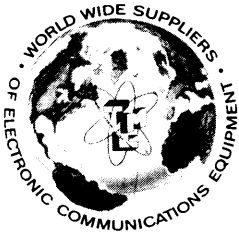

## Section 2 - Installation

---

### 2.1 Initial Inspection

#### 2.1.1 General

The TRC-5K is shipped in one container and is completely assembled at the time of delivery from the factory. Every TRC-5K undergoes a thorough testing prior to shipment. Upon receipt of the unit, check the packing case and its contents for obvious damage. Unpack the equipment carefully to reduce the risk of damage and to avoid misplacing any parts shipped as loose items. See Table 2.1 for a list of the loose items.

#### 2.1.2 Damage By Carrier

With respect to equipment damage for which the carrier is liable, TMC will assist in describing methods of repair as well as furnishing replacement parts.

### 2.2 Electrical Installation

#### 2.2.1 General

Each unit has been factory tested and arrives ready for immediate installation and operation. No preliminary adjustments are necessary.

#### 2.2.2 Mounting

The TRC-5K is designed for either pole or wall mounting. For pole mounting, two mounting straps and the necessary lag bolts are provided. For wall mounting, four mounting brackets attached to the unit case are used. Figure 2.2 illustrates the necessary outline and mounting dimensions of the TRC-5K. Figure 2.1 is a schematic illustration of a typical rhombic antenna system in conjunction with the TRC-5K.

#### 2.2.3 External Antenna Connections

The two antenna input leads are connected to the two insulator bowl terminal connectors of the TRC-5K. These bowls are located on each side of the TRC case.

#### 2.2.4 External Coaxial Connections

The coaxial lead-in cable is connected to the TRC-5K RF connector assembly located on the bottom of the case.

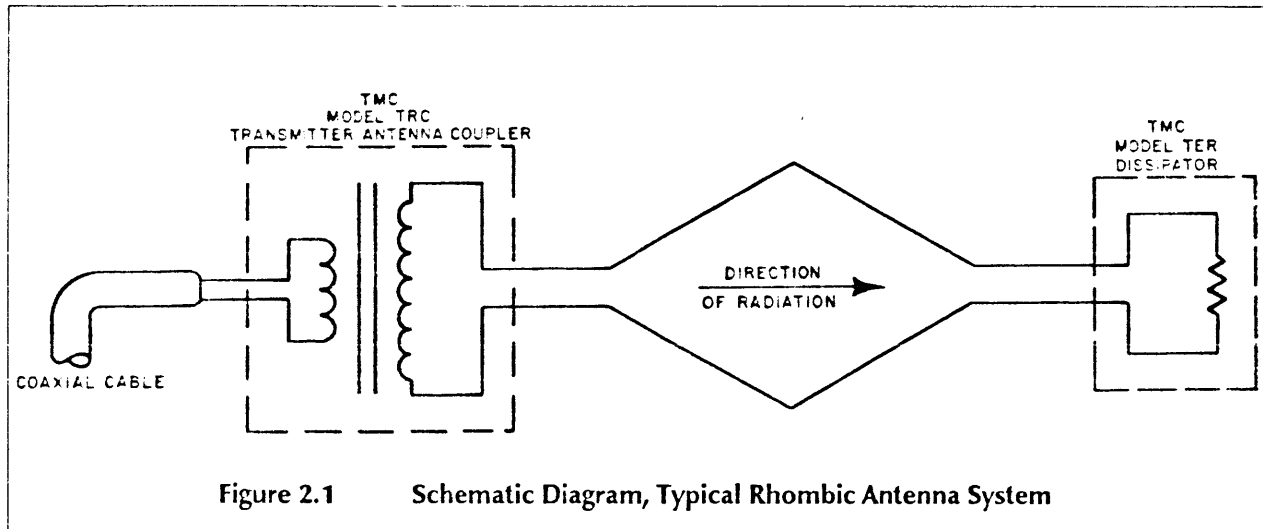
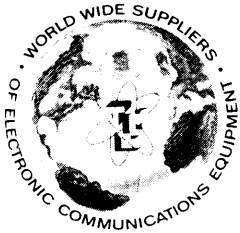

## 2.3 Performance Check

### 2.3.1 General

When the appropriate RF connections to the antenna and the coaxial lead-in cable have been made, the TRC-5K is ready for use. No further steps are required.

**Table 2.1 - Loose Items Supplied**

(Refer to Figure 2.2 for a CALL-OUT of parts by item number.)

Item	TMC Part Number	Description	Quantity
1	SC145-2	Lag Bolt	4 each
2	SCHH3118SS20	Machine Bolt	4 each
3	MS2680	Mounting Bracket	4 each
4	NTH3118SS16	Hexagonal Nut	4 each
5	MS619-1	Mounting Strap	4 each
6	FW31HSS	Flat Washer	8 each
7	LWS31MSS	Split Lock Washer	4 each

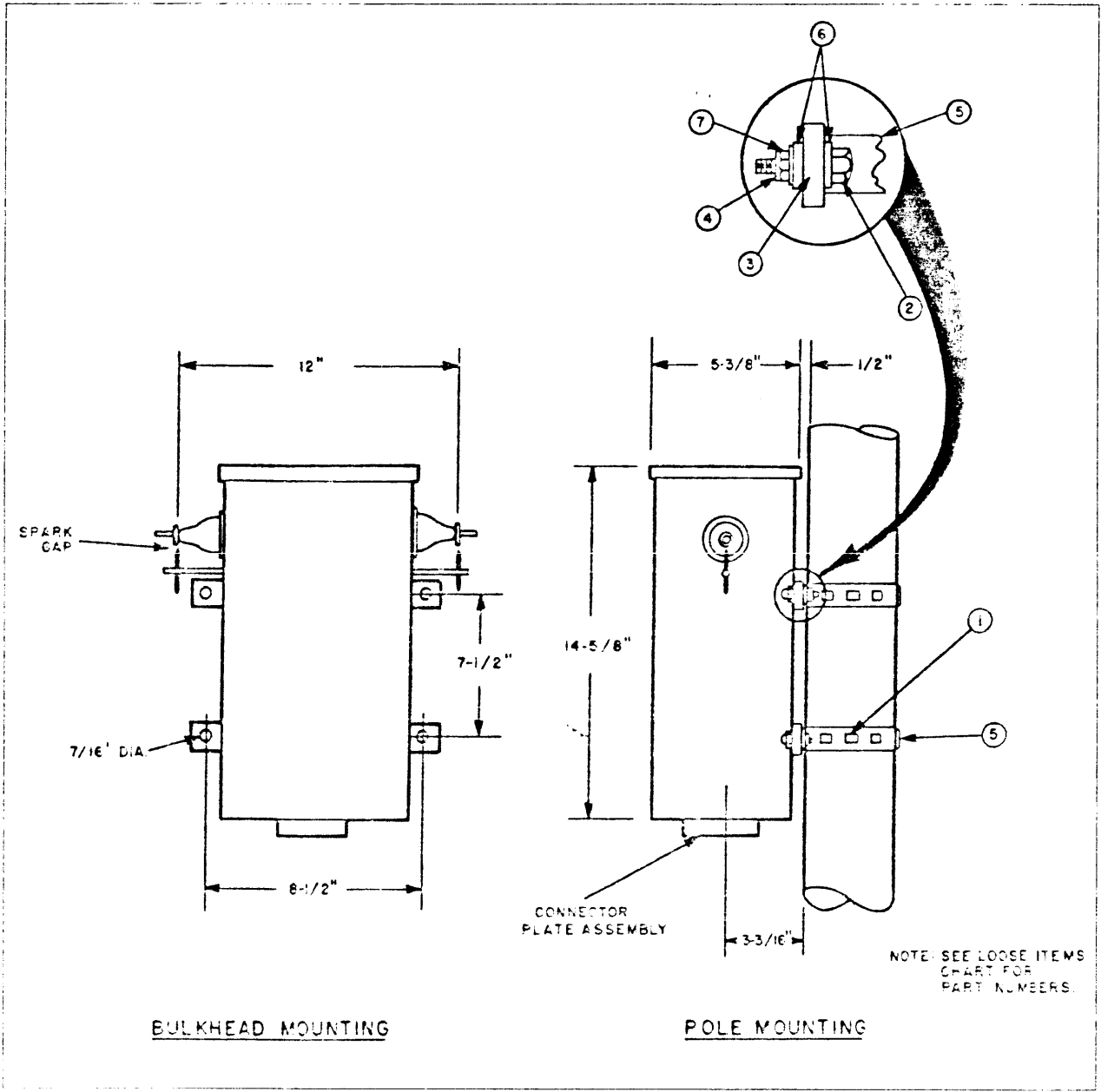
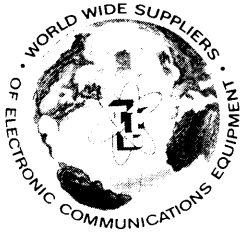
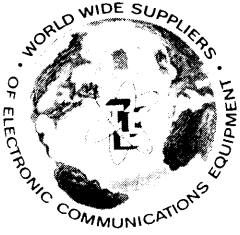

Figure 2.2 Outline Drawing with Mounting Dimensions



## **Section 3 - Operation**

---

### **3.1 General**

After connecting the antenna leads and coaxial lead-in cable, as described In **Section 2 - Installation**, no further operating procedures are required. The TRC-5K is now fully operational without further adjustment.

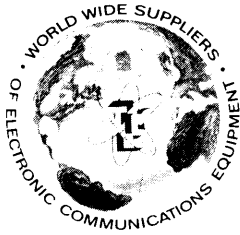

## Section 4 - Maintenance

### 4.1 General

Due to the simplicity of construction and design of the TRC-5K, maintenance may simply consist of looking for secure connections and unit cleanliness.

### 4.2 Preventive Maintenance

#### 4.2.1 General Cleaning Methods

Preventive maintenance for the TRC consists of routine functions such as visual inspection and cleaning. Periodic cleaning is recommended as dust may build up on components, reducing the efficiency of the coupler unit and possibly causing circuit failure. To facilitate cleaning the unit, use a vacuum cleaner or a low-pressure filtered compressed-air supply.

#### 4.2.2 Visual Check

A simple visual check of the unit when it is opened up for servicing or cleaning will often reveal potential trouble spots and thereby reduce downtime due to component failure. Signs of trouble may be found in discoloration, warped printed circuit boards and damaged wiring or cables. Any deteriorating component should be replaced immediately. All hardware should be checked for tightness during preventive maintenance inspections.

### 4.3 Troubleshooting

#### 4.3.1 General Failure Symptoms

During operation of the TRC, the following failure symptom may be observed:

- No signal output or weak signal to the antenna system.

Possible Cause: Transmitter failure (Output affected)  
Remedial Action: Refer to transmitter or transceiver manual

Possible Cause: Interconnection, coupler to transmitter  
Remedial Action: Check the RF coaxial cable between the transmitter and coupler.

Possible Cause: Interconnection, coupler to antenna  
Remedial Action: Check the twin RF leads between the coupler and the antenna.

Possible Cause: Antenna fault  
Remedial Action: Check for a fault in the antenna system. Make certain all of the RF connections are securely fastened.

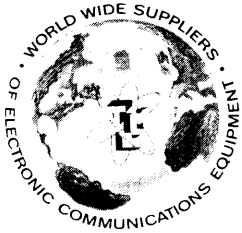

## 5.4 Repair

Repair work generally consists of replacing the defective component. The following cautions should be observed:

- Make sure the replacement component is an exact duplicate of the defective one.
- Place any new component in the same location as the component it replaces.

**The TRC-5K is unique in that only one electrical assembly is used. Other than external components such as the spark gap protection assemblies and the hardware, repair is rarely needed. In the event the internal transformer fails - a direct lightning hit would do it - the case may be opened and the entire assembly replaced. Factory repair of the TRC-5K is also available directly from TMC.**



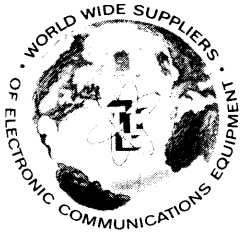

## Section 5 - Parts Lists

### Table 5.1 Replacement Spare Parts List

(Refer to Figure 5.1 for CALL-OUT of parts by item number.)

Item	TMC Part Number	Description	Quantity
1	NS115	Insulator Bowl	4 each
2	PM723-INR	Spark Gap Contact, Round	2 each
3	GA126	Inner Gasket	4 each
4	GA1511	Shoulder Gasket	4 each
5	PM724-INR	Spark Gap Contact, Rod	2 each

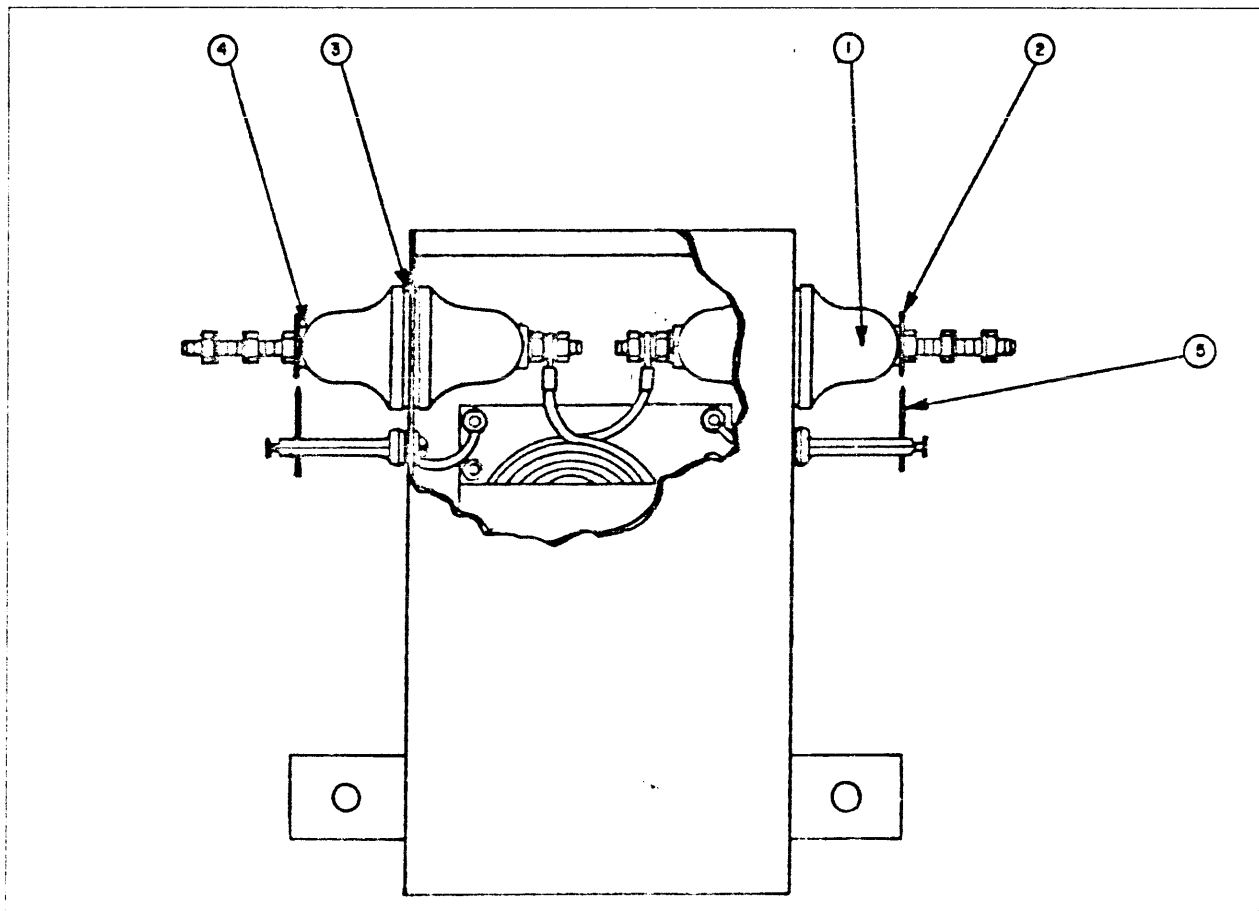

Figure 5.1 Cutaway View, Model TRC-5K