

TECHNICAL MANUAL
for
**HARMONIC FILTER
MODEL TFP()-1K**

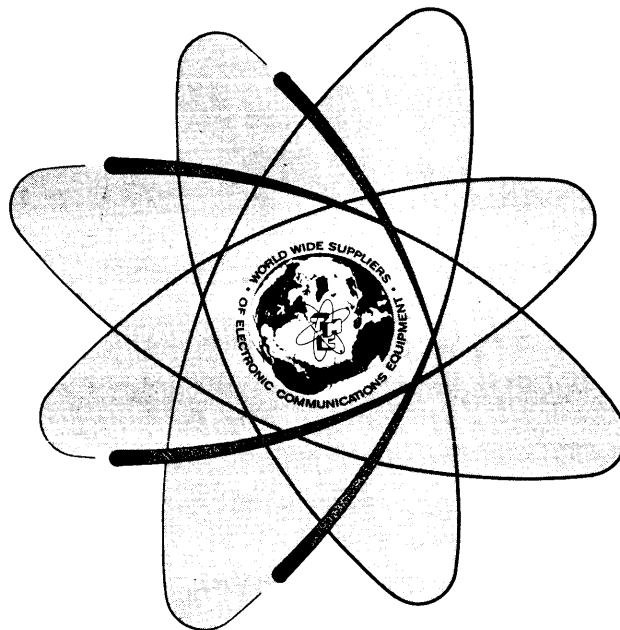

THE TECHNICAL MATERIEL CORPORATION
MAMARONECK, N. Y. OTTAWA, ONTARIO

COPYRIGHT 1971
THE TECHNICAL MATERIEL CORPORATION

Printed in U.S.A.

IN 2055

Issue Date: MAY 1971

NOTICE

THE CONTENTS AND INFORMATION CONTAINED
IN THIS INSTRUCTION MANUAL IS PROPRIETARY
TO THE TECHNICAL MATERIEL CORPORATION
TO BE USED AS A GUIDE TO THE OPERATION
AND MAINTENANCE OF THE EQUIPMENT FOR
WHICH THE MANUAL IS ISSUED AND MAY NOT
BE DUPLICATED EITHER IN WHOLE OR IN
PART BY ANY MEANS WHATSOEVER WITHOUT
THE WRITTEN CONSENT OF THE TECHNICAL
MATERIEL CORPORATION.



THE TECHNICAL MATERIEL CORPORATION

C O M M U N I C A T I O N S E N G I N E E R S

700 FENIMORE ROAD

MAMARONECK, N. Y.

Warranty

The Technical Materiel Corporation, hereinafter referred to as TMC, warrants the equipment (except electron tubes,*fuses, lamps, batteries and articles made of glass or other fragile or other expendable materials) purchased hereunder to be free from defect in materials and workmanship under normal use and service, when used for the purposes for which the same is designed, for a period of one year from the date of delivery F.O.B. factory. TMC further warrants that the equipment will perform in a manner equal to or better than published technical specifications as amended by any additions or corrections thereto accompanying the formal equipment offer.

TMC will replace or repair any such defective items, F.O.B. factory, which may fail within the stated warranty period, PROVIDED:

1. That any claim of defect under this warranty is made within sixty (60) days after discovery thereof and that inspection by TMC, if required, indicates the validity of such claim to TMC's satisfaction.
2. That the defect is not the result of damage incurred in shipment from or to the factory.
3. That the equipment has not been altered in any way either as to design or use whether by replacement parts not supplied or approved by TMC, or otherwise.
4. That any equipment or accessories furnished but not manufactured by TMC, or not of TMC design shall be subject only to such adjustments as TMC may obtain from the supplier thereof.

Electron tubes*furnished by TMC, but manufactured by others, bear only the warranty given by such other manufacturers. Electron tube warranty claims should be made directly to the manufacturer of such tubes.

TMC's obligation under this warranty is limited to the repair or replacement of defective parts with the exceptions noted above.

At TMC's option any defective part or equipment which fails within the warranty period shall be returned to TMC's factory for inspection, properly packed with shipping charges prepaid. No parts or equipment shall be returned to TMC, unless a return authorization is issued by TMC.

No warranties, express or implied, other than those specifically set forth herein shall be applicable to any equipment manufactured or furnished by TMC and the foregoing warranty shall constitute the Buyers sole right and remedy. In no event does TMC assume any liability for consequential damages, or for loss, damage or expense directly or indirectly arising from the use of TMC Products, or any inability to use them either separately or in combination with other equipment or materials or from any other cause.

*Electron tubes also include semi-conductor devices.

PROCEDURE FOR RETURN OF MATERIAL OR EQUIPMENT

Should it be necessary to return equipment or material for repair or replacement, whether within warranty or otherwise, a return authorization must be obtained from TMC prior to shipment. The request for return authorization should include the following information:

1. Model Number of Equipment.
2. Serial Number of Equipment.
3. TMC Part Number.
4. Nature of defect or cause of failure.
5. The contract or purchase order under which equipment was delivered.

PROCEDURE FOR ORDERING REPLACEMENT PARTS

When ordering replacement parts, the following information must be included in the order as applicable:

1. Quantity Required.
2. TMC Part Number.
3. Equipment in which used by TMC or Military Model Number.
4. Brief Description of the Item.
5. The *Crystal Frequency* if the order includes crystals.

PROCEDURE IN THE EVENT OF DAMAGE INCURRED IN SHIPMENT

TMC's Warranty specifically excludes damage incurred in shipment to or from the factory. In the event equipment is received in damaged condition, the carrier should be notified immediately. Claims for such damage should be filed with the carrier involved and not with TMC.

All correspondence pertaining to Warranty Claims, return, repair, or replacement and all material or equipment returned for repair or replacement, within Warranty or otherwise, should be addressed as follows:

THE TECHNICAL MATERIEL CORPORATION
Engineering Services Department
700 Fenimore Road
Mamaroneck, New York

TABLE OF CONTENTS

<u>Paragraph</u>		<u>Page</u>
	<u>SECTION 1 - GENERAL INFORMATION</u>	
1-1	Functional Description	1-1
1-2	Physical Description	1-1
1-3	Technical Specifications	1-1
	<u>SECTION 2 - INSTALLATION</u>	
2-1	Unpacking and Handling	2-1
2-2	Mechanical Installation	2-1
2-3	Electrical Installation	2-2
	<u>SECTION 3 - OPERATOR'S SECTION</u>	
3-1	Operating Instructions	3-1
	<u>SECTION 4 - PRINCIPLES OF OPERATION</u>	
4-1	General	4-1
4-2	Block Diagram Description	4-1
	<u>SECTION 5 - MAINTENANCE</u>	
5-1	Preventive Maintenance	5-1
5-2	Troubleshooting	5-1
5-3	Repair and Replacement	5-5
	<u>SECTION 6 - PARTS LIST</u>	
6-1	Introduction	6-1
	<u>SECTION 7 - SCHEMATIC DIAGRAMS</u>	

LIST OF ILLUSTRATIONS

<u>Figure</u>		<u>Page</u>
	<u>SECTION 1 - GENERAL INFORMATION</u>	
1-1	Harmonic Filter, Model TFP-1K	1-0
	<u>SECTION 2 - INSTALLATION</u>	
2-1	Tilt-Lock Slide Mechanism Details	2-2
2-2	Typical Interconnection Diagram	2-3
	<u>SECTION 3 - OPERATOR'S SECTION</u>	
3-1	Front Panel Control	3-1
	<u>SECTION 4 - PRINCIPLES OF OPERATION</u>	
4-1	Simplified Block Diagram	4-4
	<u>SECTION 5 - MAINTENANCE</u>	
5-1	Bottom Chassis Component Layout	5-6
	<u>SECTION 7 - SCHEMATIC DIAGRAMS</u>	
7-1	Schematic Diagram, TFP-1K, Sheet 1 of 2	7-2/7-3
7-2	Schematic Diagram, TFP-1K, Sheet 2 of 2	7-4/7-5

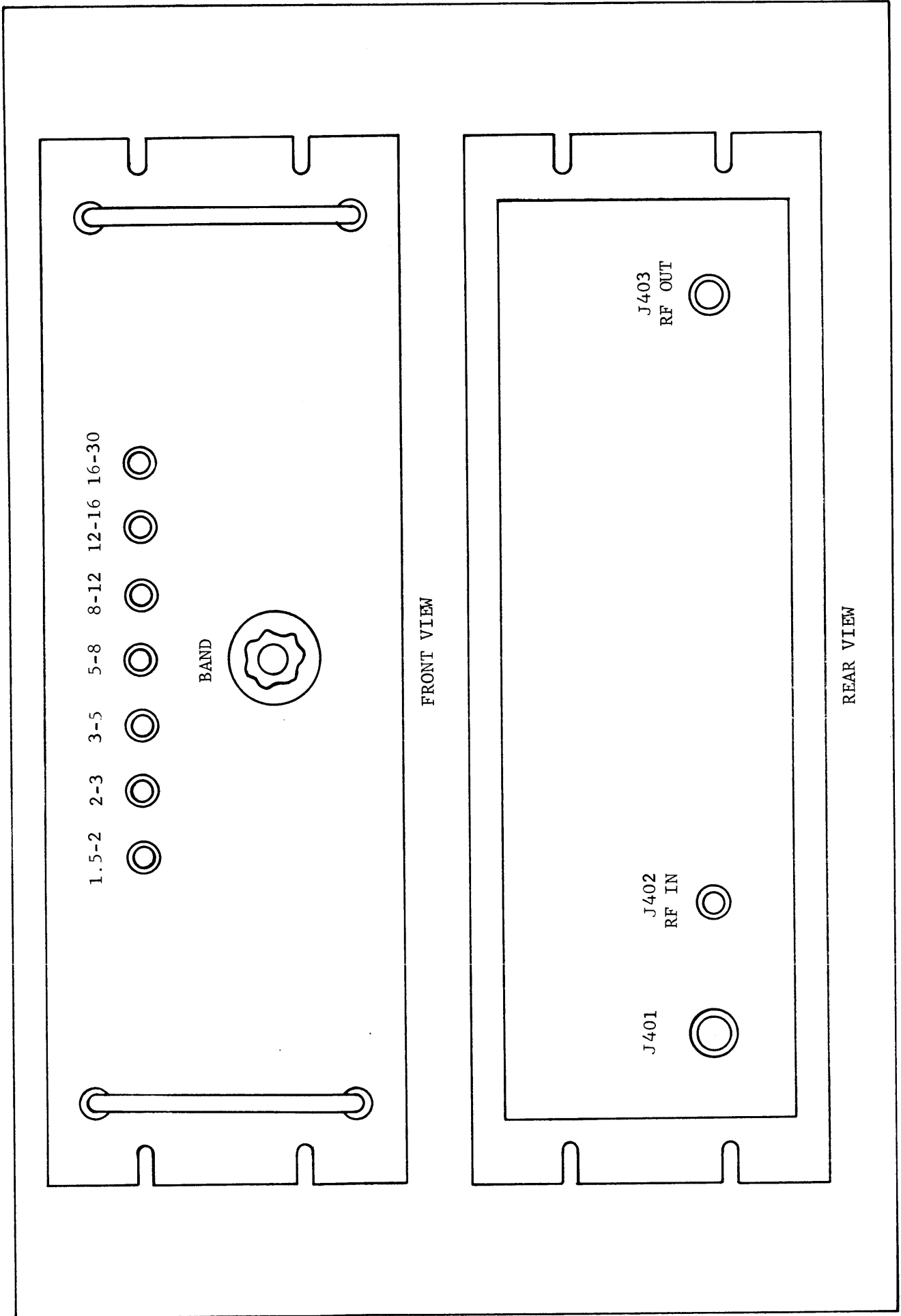

FIGURE 1-1. HARMONIC FILTER, MODEL TFP-1K

SECTION 1

GENERAL INFORMATION

1-1. FUNCTIONAL DESCRIPTION

Harmonic Filter, Model TFP-1K (figure 1-1) is an automatically switched harmonic filter unit, designed to operate in conjunction with the HFT()-1K transmitters operating in the 1.5 to 30 MHz frequency range.

Functionally the TFP-1K is an in/out filter configuration. The transmitter operating frequency is routed through a frequency corresponding harmonic filter network, the output of which is harmonically suppressed to meet FCC harmonic suppression requirements.

Harmonic filtering is accomplished by seven harmonic filter networks within the TFP.

1-2. PHYSICAL DESCRIPTION

The TFP-1K is equipped with a 19 inch wide front panel, suitable for mounting into any standard equipment rack or console.

The unit measures 5½ inches high supporting a 17 inch deep chassis.

The front panel displays one control, a seven-position filter BAND rotary selector switch and seven filter band indicator lights. The rear chassis contains three connectors: an RF INPUT connector J402, an RF OUTPUT connector J403, and a control input cable connector J401.

1-3. TECHNICAL SPECIFICATIONS

Harmonic Filter Range:	1.5 to 30 MHz in seven selectable positions:
	1.5 - 2 MHz
	2 - 3 MHz
	3 - 5 MHz
	5 - 8 MHz
	8 - 12 MHz
	12 - 16 MHz
	16 - 30 MHz

Dimensions:

19 inches wide X $5\frac{1}{4}$ inches high
X 17 inches deep.

Power Requirements:

36 vac from an external source
for relay and stepping switch
operation.

SECTION 2 INSTALLATION

2-1. UNPACKING AND HANDLING

The TFP is tested at the factory and is carefully packaged to prevent damage during shipment. Upon receipt of the equipment, inspect the packing case and its contents for damage that might have occurred during transit. Unpack the equipment carefully and inspect all packing material for parts that may have been shipped as loose items. With respect to damage to the equipment for which the carrier is liable, The Technical Materiel Corporation will assist in describing methods of repair and the furnishing of replacement parts.

2-2. MECHANICAL INSTALLATION

The TFP is equipped with a standard 19 inch wide front panel and is designed for installation in an equipment cabinet. Refer to figure 2-1 and install the unit in the rack as follows:

- a. Pull out center sections of tracks, located in the equipment rack, until they lock in extended position.
- b. Position slide mechanisms of TFP in tracks, and ease unit into rack until release fingers engage holes in tracks.
- c. Depress release fingers and slide unit completely into rack.

NOTE

To prevent the cables from snagging, attach cable retractors (located inside the rack) to the cables before sliding the unit into the rack.

- d. Make necessary cable and electrical connections as described in paragraph 2-3.
- e. Secure front panel of TFP to rack with screws and washers.

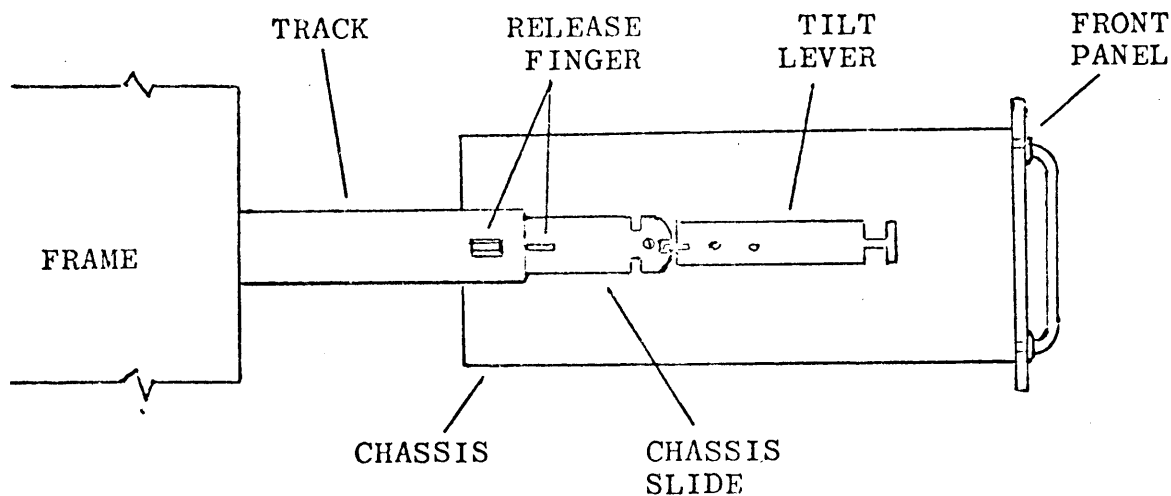

Figure 2-1. Tilt-Lock Slide Mechanism Details

2-3. ELECTRICAL INSTALLATION

a. Power Requirements

The TFP operates from voltages received from the associated transmitter system; 36 vac is required for relay and stepping switch solenoid operation.

b. Interconnections

Refer to the interconnect cabling diagram provided in the associated system manual and make the cabling connections between the TFP and related units as indicated. All connections to the TFP are made at the rear panel.

See figure 2-2 for a typical interconnection diagram of the TFP in relation to a typical transmitter system configuration.

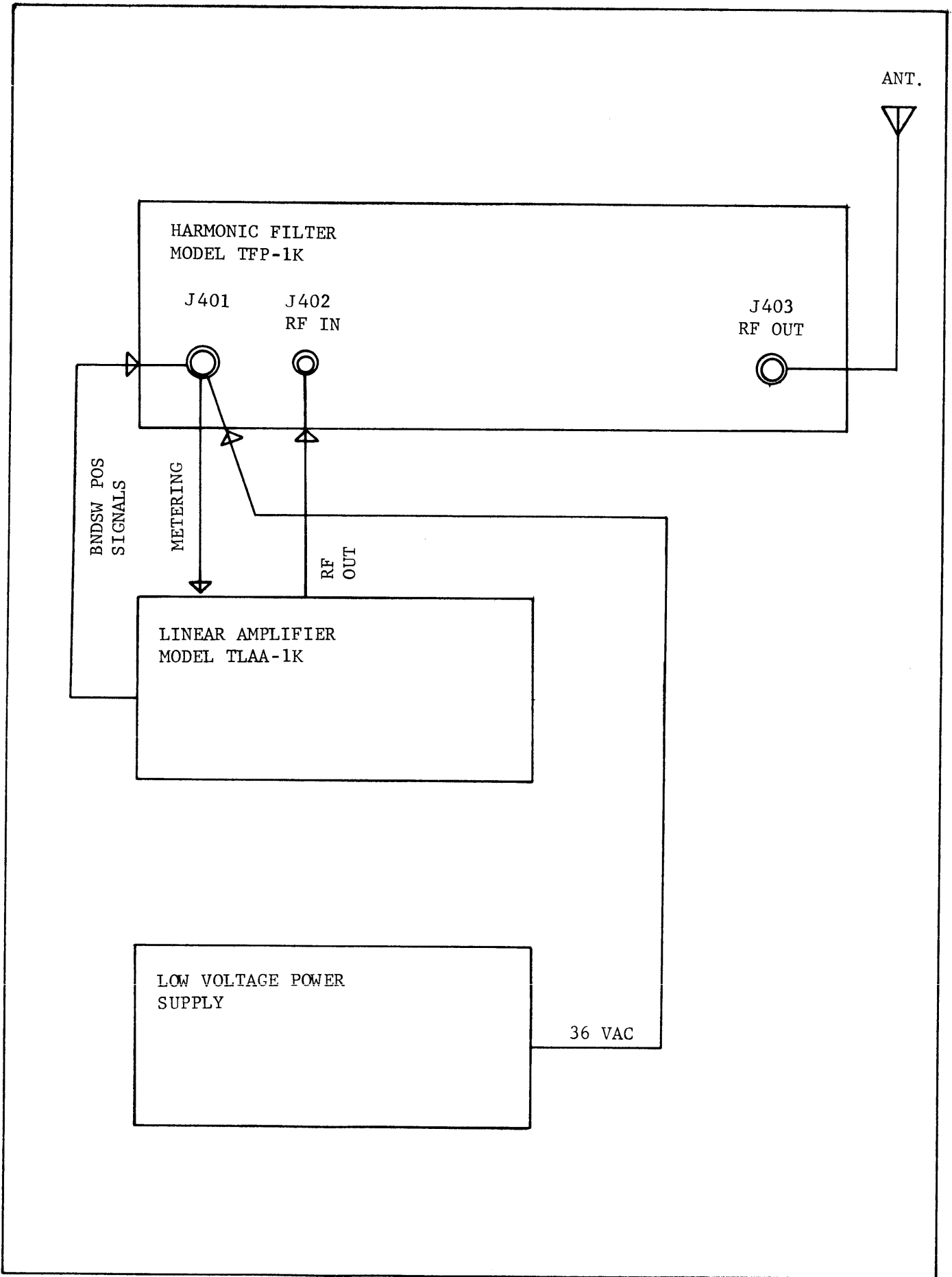

FIGURE 2-2. TYPICAL INTERCONNECTION DIAGRAM

SECTION 3 OPERATOR'S SECTION

3-1. OPERATING INSTRUCTIONS

The TFP contains one operating control, a front panel mounted seven position filter band rotary solenoid switch. The 1.5 to 30 MHz frequency range is covered in seven positions: 1.5-2 MHz, 2-3 MHz, 3-5 MHz, 5-8 MHz, 8-12 MHz, 12-16 MHz and 16-30 MHz. Refer to figure 3-1.

The filter band control is used to select the appropriate harmonic filter network corresponding to the transmitter operating frequency. Band selections are made automatically in conjunction with transmitter band position. (Manual selection is provided in the event of solenoid failure.)

Manual selection is accomplished by manually setting the filter band control to a band that includes the frequency band setting of the transmitter's bandswitch control. Should the filter bandswitch be mistakenly set to the improper filter network setting, the transmitter will be in a standby condition (biased off).

Automatic selection is accomplished by a positioning signal, initiated by the transmitter's frequency bandswitch control, automatically positioning the FILTER BANDSWITCH control to the proper setting.

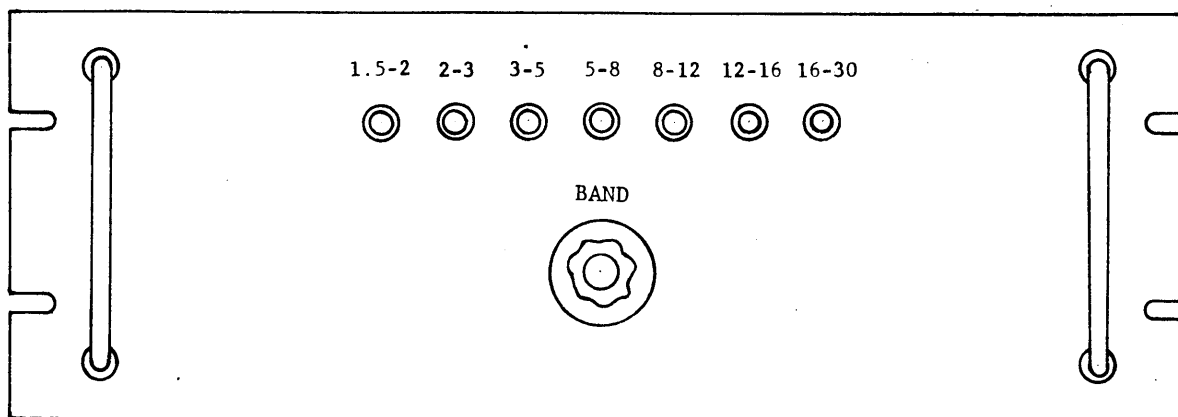

FIGURE 3-1. FRONT PANEL CONTROL

SECTION 4

PRINCIPLES OF OPERATION

4-1. GENERAL

The TFP is an in/out filter configuration. The selected transmitter frequency, in the 1.5 MHz to 30 MHz range, is applied at the input connector J402 of the TFP, routed through a corresponding frequency harmonic filter network, and through the directional coupler to the transmitter system's antenna.

The TFP is configured to cover the 1.5 MHz to 30 MHz frequency range in seven separate harmonic filter networks. These seven filter networks (1.5-2 MHz, 2-3 MHz, 3-5 MHz, 5-8 MHz, 8-12 MHz, 12-16 MHz, 16-30 MHz) are selected automatically via transmitter control circuitry. The filter band control is a seven position, ledex controlled rotary stepping switch, that receives the proper filter frequency positioning control voltages from the transmitter system. The filter band control, being slave controlled by the transmitter, is automatically set to the proper harmonic filter setting within the selected transmitter operating frequency.

The filter band control may also be set manually to the desired setting in the event of ledex motor control failure. However, to ensure that the filter band is set at the proper position, including the selected transmitter operating frequency, a filter protection system is employed. If the filter band is incorrectly positioned, the transmitter will not operate.

4-2. BLOCK DIAGRAM DESCRIPTION (Refer to figure 4-1)

The selected transmitter RF output, from the transmitter system's linear amplifier section, is applied to the wiper of the filter band control (S402) via RF Input connector J402. The filter band control is

set automatically to the correct filter position within the selected transmitter frequency range. The RF is then routed through that harmonic filter network.

The filtered output, harmonically suppressed to meet FCC requirements, is then routed through the directional coupler, DC401 to the OUTPUT connector J403. The harmonic filter networks are employed for all operating frequencies in the frequency range of 1.5-30 MHz.

Automatic filter band positioning is accomplished by control voltages, initiated in the transmitter and applied to connector J401 in the TFP. The control voltages are applied to the stepping switch solenoid of the filter band control via contacts on filter relay K401.

The control voltage derived in the transmitter is routed to a particular switch position of S401A. This voltage, appearing at a position corresponding to the transmitter system's operating frequency band, is routed through the wiper of S401A to the solenoid of relay K401.

Relay K401 energizes and closes a set of normally open contacts. The closed contacts of relay K401 then route a 36 vac potential, from the system's power supply, to the filter band stepping switch solenoid. The stepping switch solenoid will then rotate the filter band control until it reaches the predetermined switch position corresponding to the transmitter system's operating frequency band. Stopping the filter bandswitch at the predetermined setting is accomplished when the slotted portion of the S401A switch ring, rotated by the stepping switch solenoid, reaches the voltage bearing contact. At this point, the energizing voltage for the relay solenoid of K401 is removed, deenergizing it and thereby removing the 36 vac control voltage from the stepping switch solenoid.

Filter band switch protection of improper positioning of the band switch is performed by relay K401. Relay K401 is energized via a voltage

appearing at switch S401A front wafer, When K401 energizes the normally closed contacts 5 and 8 of K401 open. Relay contact 5 is connected to the PTT (push-to-talk) relay coil located in the low voltage power supply. Relay contact 8 is part of the transmitter's control circuitry that is connected to the second side of the PTT relay coil.

When the filter bandswitch is in the correct position relay K401 is deenergized and the normally closed contacts 5 and 8 complete the line to the PTT relay and it energizes. Energized PTT relay acts upon the transmitter bias circuitry in such a manner that normal operating bias voltages are established when the PTT relay is energized.

Improper positioning of the filter band switch will cause filter band relay K401 to remain energized, opening the normally closed contacts 5 and 8 which will cause the PTT relay to deenergize. Deenergized PTT relay will react upon the transmitters bias circuitry to produce maximum bias voltage to the RF amplifier tubes, placing them at or near cutoff.

The TFP is protected against improper positioning by the action of filter band relay K401 in conjunction with the PTT relay located in the transmitter low voltage supply.

The filter bandswitch position control voltage, stepping switch control solenoid voltage, and system wiring are all routed via connector J401.

The aforementioned paragraphs have described the TFP in a configuration used with the HFT()-1K series of transmitters, however the same principle may also be used in any one kilowatt transmitter with slight modifications.

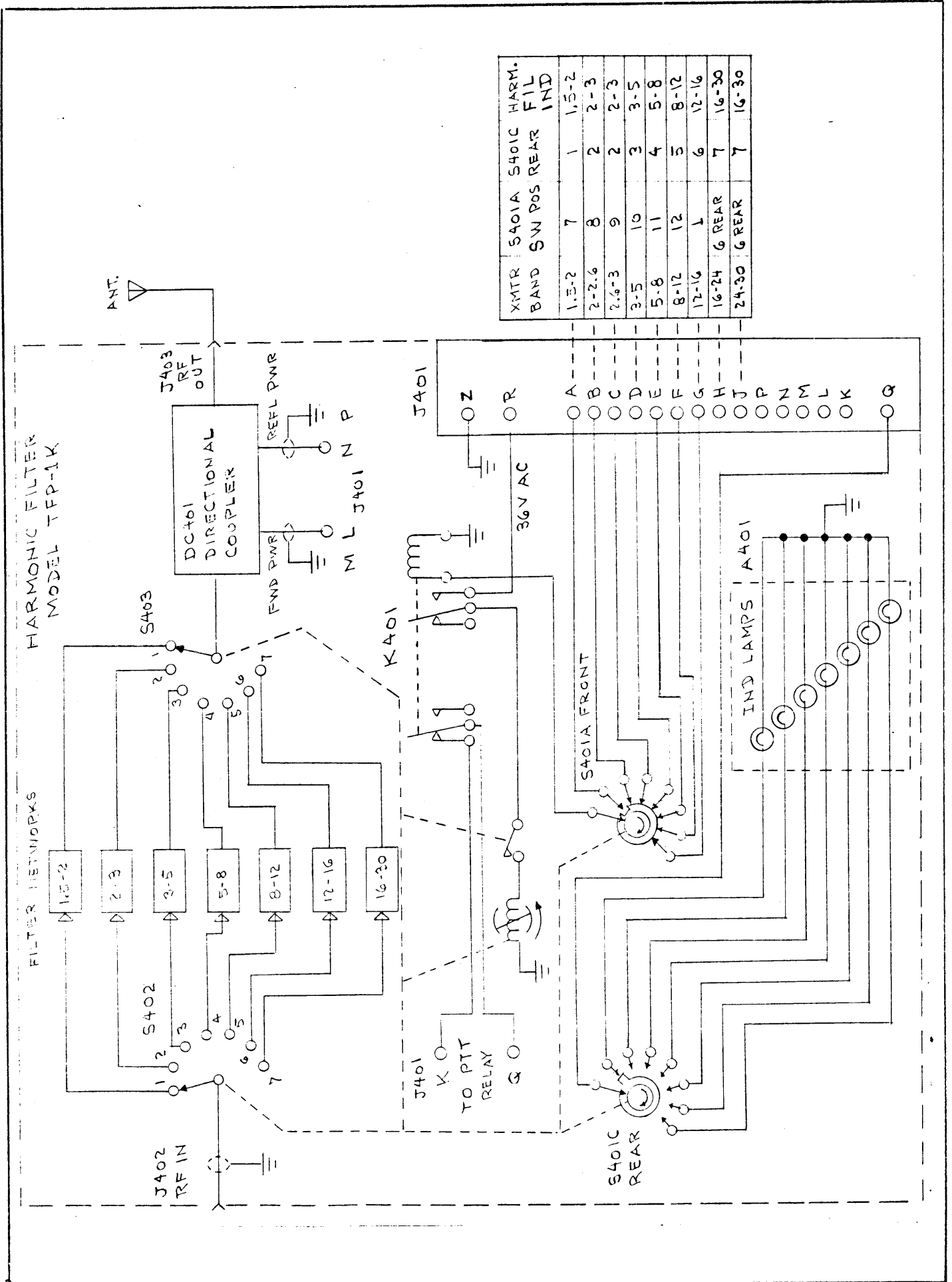

FIGURE 4-1. SIMPLIFIED BLOCK DIAGRAM

SECTION 5

MAINTENANCE

5-1. PREVENTIVE MAINTENANCE

In order to prevent equipment failure due to dust, dirt or other destructive elements, it is suggested that a schedule of preventive maintenance be set up and adhered to.

At periodic intervals, the equipment should be removed from its mounting for cleaning and inspection. The wiring and all components should be inspected for dirt, dust, corrosion, grease or other harmful conditions. Remove dust with a soft brush or vacuum cleaner. Remove dirt or grease with any suitable cleaning solvent. Use of carbon tetrachloride should be avoided due to its highly toxic effects. Trichlorethylene or methylchloroform may be used, providing the necessary precautions are observed.

WARNING

WHEN USING TOXIC SOLVENTS, MAKE CERTAIN THAT ADEQUATE VENTILATION EXISTS. AVOID PROLONGED OR REPEATED BREATHING OF THE VAPOR. AVOID PROLONGED OR REPEATED CONTACT WITH SKIN. FLAMMABLE SOLVENTS SHALL NOT BE USED ON ENERGIZED EQUIPMENT OR NEAR ANY EQUIPMENT FROM WHICH A SPARK MAY BE RECEIVED. SMOKING, "HOT WORK", ETC. IS PROHIBITED IN THE IMMEDIATE AREA.

CAUTION

When using trichlorethylene, avoid contact with painted surfaces, due to its paint removing effects.

5-2. TROUBLESHOOTING

When a piece of equipment has been operating satisfactorily and suddenly fails, the cause of failure may be due to symptoms of past failures or due to component ageing.

The first step in troubleshooting is to ascertain that proper equipment voltages are present and that all interconnecting cables are secure and functional.

If the above mentioned checks fail to locate the fault, and the fault is known to be that of the TFP, disconnect all interconnecting cables and remove unit from its mounting. Remove access cover and perform a visual check. Observe for trouble causing conditions such as arcing, grease, dirt, dust or other harmful conditions. Observe for loose connections, broken or burned wires, charred or discolored components. Proceed with the following troubleshooting procedures.

In order to isolate the trouble causing condition in the TFP, the technician should perform a systematic continuity check of the various TFP component sections. These sections may be categorized as: the harmonic filter sections, stepping switch S401, relay K401, filter band-switching circuit S402 and S403, and their associated harness and cable wiring.

The first logical step is to ascertain that the inter-system cabling is correct, operative, and that the required voltages and terminations to the TFP are correct and available. After a general overall visual inspection of the unit, proceed with a continuity check of the filter band-switching circuit S402 and its associated intercabling and wiring.

Refer to figure 7-1 sheet 2 and proceed with a continuity check starting from the RF INPUT jack J402. Continuity should be present from J402 to the wiper of S402. Proceed by measuring for continuity from RF IN jack J402 to RF OUT jack J403 (switching the filter band control through the 1.5-2 MHz to 16-30 MHz positions respectfully). Continuity through all seven positions indicates that the input circuit to the harmonic filter sections is functional.

Perform a short circuit check for the harmonic filter input and output circuit. This is performed by measuring from the RF INPUT connector J402 to ground and RF OUTPUT connector J403 to ground. This check is similar to the preceding continuity check, switching the Filter Bandswitch through the 1.5-2 to 16-30 MHz positions. There should be no low resistance or short circuit indications.

Continuity across all of the preceding described points and no indications of short circuits establishes the functional condition of the harmonic filter input/output circuit.

To check the condition of relay K401 (refer to figure 7-1 sheet 1) the technician may remove the relay from it's socket and measure for continuity and resistance across the relay terminals. The relay solenoid, measured across terminals 2 and 7 should read approximately 400 ohms. Continuity should be present across terminals 5 and 8 and terminals 4 and 1. An open condition should therefore be measured across terminals 6 and 8 and terminals 3 and 1. A similar check of the relay K401 plug-in socket should follow. Terminal 7 of relay K401 plug-in socket should measure continuity to ground. Terminal 2 should measure continuity to the wiper terminal of switch wafer S401A front. Terminal 1 should measure continuity to pin R of connector J401. Terminal 3 should measure continuity to the input of the stepping switch contactor arm. Terminals 4 and 6 are intentionally unused.

The stepping switch wafers S401A front and rear contacts are all directly wired to connector J401. To check the S401A front section, proceed as follows: Check for continuity from the wiper (terminal 2 of relay K401 plug-in socket) to connector J401. Continuity should be measured across pins A through G of connector J401, except at the pin corresponding to the selected Filter Bandswitch setting, i.e., when set

at the 1.5-2 position an open indication should be measured from the wiper to pin A of J401, all other pins B through G should measure continuity. Repeat this check through all seven Filter Bandswitch positions.

To check the S401C section, proceed as follows: Check for continuity from the wiper of S401C (pin Q of J401) to the pin corresponding to the FILTER BANDSWITCH setting, i.e., when set at the 1.5-2 position, continuity should be measured at terminal 2 of Filter Band Indicator PC board A401, measuring an open indication at the remaining pins. Repeat this check through all seven Filter Bandswitch position.

The stepping switch solenoid of S401 operates from an externally produced 36 volts ac. Therefore, the surest method for checking the condition of the motor is to apply a 36 vac potential to the input contactor arm via terminal 3 of relay K401 plug-in socket, with relay removed. Application of 36 vac to the stepping switch solenoid should cause it to operate. While the switch wafer is rotating, visually inspect the components, i.e., switch wafers, shaft, shaft-couplers, etc, for smooth and trouble free operation.

Assuming that all preceding checks failed to locate the fault, it may be assumed that the fault lies in the harmonic filter sections. The faulty harmonic filter section should be evident to the particular Filter Bandswitch control range used when the fault occurred.

Observe the suspected harmonic filter section and inspect, check and replace the faulty component.

The preceding checks may be further enhanced or shortened as to the technicians own methods, troubleshooting techniques and short-cuts. Use of the schematic diagram in section 7 and the parts list in section 6 should be used as a guide and reference.

5-3. REPAIR AND REPLACEMENT

Maintenance of the TFP will consist mainly of component replacement, requiring no tuning or aligning. It should be noted that when replacing components having many wires connected, such as switches, relays, etc., the wires should first be tagged and marked for accurate identification for replacement.

When replacing components, the technician should observe for exact or equivalent replacements, by referring to the parts list in section 6.

Positioning and polarity of certain components should be observed before removing, so that the replacement component will fit and operate correctly. See figure 5-1 for component locations.

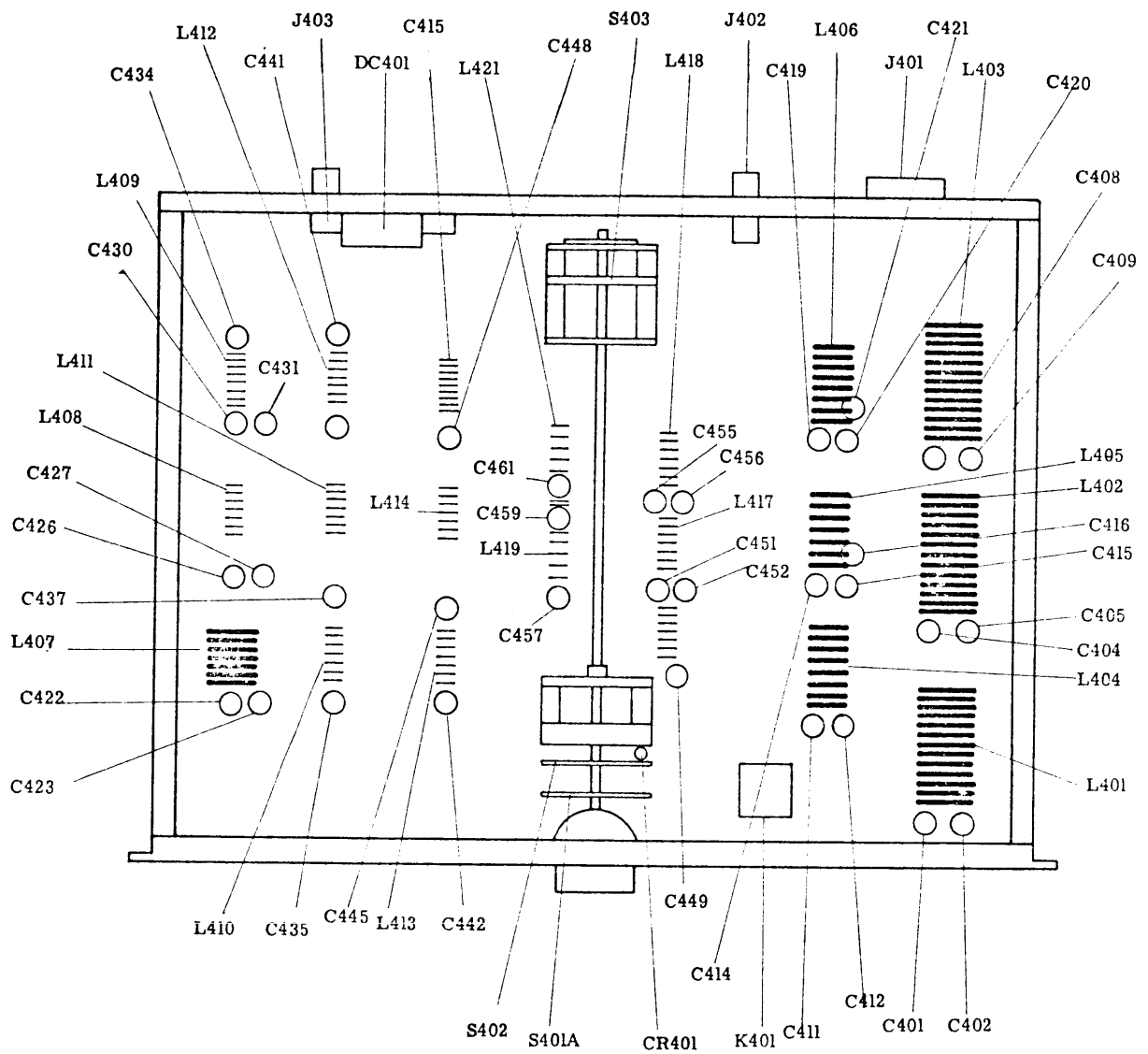

Figure 5-1. Bottom Chassis Component Layout

SECTION 6

PARTS LIST

6-1. INTRODUCTION

The parts list presented in this section is a cross-reference list of parts identified by a reference designation and TMC part number. In most cases, parts appearing on schematic diagrams are assigned reference designations in accordance with MIL-STD-16. Wherever practicable, the reference designation is marked on the equipment, close to the part it identifies. In most cases, mechanical and electro-mechanical parts have TMC part numbers stamped on them.

To expedite delivery when ordering any part, specify the following:

- a. Reference symbol.
- b. Description as indicated in parts list.
- c. TMC part number.
- d. Model and serial numbers of the equipment containing the part being replaced; this can be obtained from the equipment nameplate.

For replacement parts not covered by warranty (refer to warranty sheet in front of manual), address all purchase orders to:

The Technical Materiel Corporation
Attention: Sales Department
700 Fenimore Road
Mamaroneck, New York

SECTION 6

PARTS LIST
TFP-1K

REF SYMBOL	DESCRIPTION	TMC PART NUMBER
A401	BD ASSY, PC IND	A4881 *
A402	BD ASSY, PC ALDC	A4850-2*
C401	CAP.,FXD,CER	CC109-38
C402	CAP.,FXD,CER	CC116-8
C403	CAP.,FXD,CER	CC116-9
C404	SAME AS C401	
C405	SAME AS C401	
C406	CAP.,FXD,CER	CC109-36
C407	SAME AS C402	
C408	SAME AS C401	
C409	SAME AS C406	
C410	SAME AS C402	
C411	SAME AS C406	
C412	SAME AS C402	
C413	SAME AS C402	
C414	SAME AS C401	
C415	SAME AS C402	
C416	CAP.,FXD,CER	CC109-19
C417	SAME AS C402	
C418	SAME AS C406	
C419	SAME AS C401	
C420	CAP.,FXD,CER	CC109-28
C421	SAME AS C416	
C422	SAME AS C406	
C423	CAP.,FXD,CER	CC116-7

TFP-1K (continued)

REF SYMBOL	DESCRIPTION	TMC PART NUMBER
C424	SAME AS C423	
C425	SAME AS C416	
C426	SAME AS C406	
C427	SAME AS C402	
C428	SAME AS C402	
C429	SAME AS C406	
C430	SAME AS C406	
C431	SAME AS C423	
C432	SAME AS C420	
C433	SAME AS C406	
C434	SAME AS C406	
C435	SAME AS C406	
C436	SAME AS C420	
C437 thru C439	SAME AS C406	
C440	SAME AS C402	
C441	SAME AS C402	
C442	SAME AS C423	
C443	SAME AS C416	
C444	CAP., FXD, CER	CC109-13
C445	SAME AS C402	
C446	SAME AS C420	
C447	SAME AS C416	
C448	SAME AS C402	
C449	SAME AS C423	

TFP-1K (continued)

REF SYMBOL	DESCRIPTION	TMC PART NUMBER
C450	SAME AS C416	
C451	SAME AS C423	
C452	SAME AS C416	
C453	SAME AS C416	
C454	SAME AS C444	
C455	SAME AS C423	
C456	SAME AS C416	
C457	SAME AS C416	
C458	SAME AS C420	
C459	SAME AS C416	
C460	SAME AS C402	
C461	SAME AS C416	
C462	CAP., FXD, CER	CC100-44
C463	SAME AS C462	
C464	CAP., FXD, CER	CC109-1
C465	CAP., FXD, CER	CM15B300J03
CR401	SCOND DEV, DIODE	1N547
CR402	SCOND DEV, DIODE	1N645
CR403 thru CR405	SAME AS CR402	
DC401	COUPLER, DIRECTIONAL	DC108
J401	CONN, RECP, ML 24/C	MS3102A24-28P
J402	CONN, RECP, HN	UG560/U
J403	SAME AS J402	
K401	REL, ARM, DPDT	RL168-2C10-24
L401	COIL, RF	CL401-16

TFP-1K (continued)

REF SYMBOL	DESCRIPTION	TMC PART NUMBER
L402	SAME AS L401	
L403]	SAME AS L401	
L404	COIL,RF	CL401-6
L405	COIL,RF	CL401-17
L406	SAME AS L404	
L407	COIL,RF	CL401-19
L408	COIL,RF	CL401-12
L409	SAME AS L408	
L410	SAME AS L408	
L411	COIL,RF	CL140-15
L412	COIL,RF	CL140-18
L413	SAME AS L412	
L414	SAME AS L411	
L415	SAME AS L412	
L416	SAME AS L411	
L417	COIL,RF	CL401-14
L418	SAME AS L417	
L419	COIL,RF	CL401-1
L420	COIL,RF	CL401-20
L421	COIL,RF	CL401-2
R401	RES,FXD,WW 10W	RW110-1
S401	SW,ROT,SOL	SW429
S402	WAFER SW	WS106-7
S403	SAME AS S402	
XK401	SOC,OCT	TS100-3

A-4881 BAND INDICATOR ASSEMBLY, PC BOARD

REF SYMBOL	DESCRIPTION	TMC PART NUMBER
C1 thru C7	CAP., FXD	CX119-104M
DS1 thru DS7	LAMP, IND	BI114-2
R1	RESISTOR, FXD, COMP	RC32GF391J
A-4850-2 ALDC ASSEMBLY, PC BOARD		
C1	CAP., FXD, CER	CC100-28
C2	SAME AS C1	
C3	CAP., FXD, CER	CE107-6
CR1	SCOND, DEV, DIO	IN34A
R1	RESISTOR, FXD, COMP	RC20GF272J
R2	RESISTOR, FXD, COMP	RC20GF102J

SECTION 7
SCHEMATIC DIAGRAMS

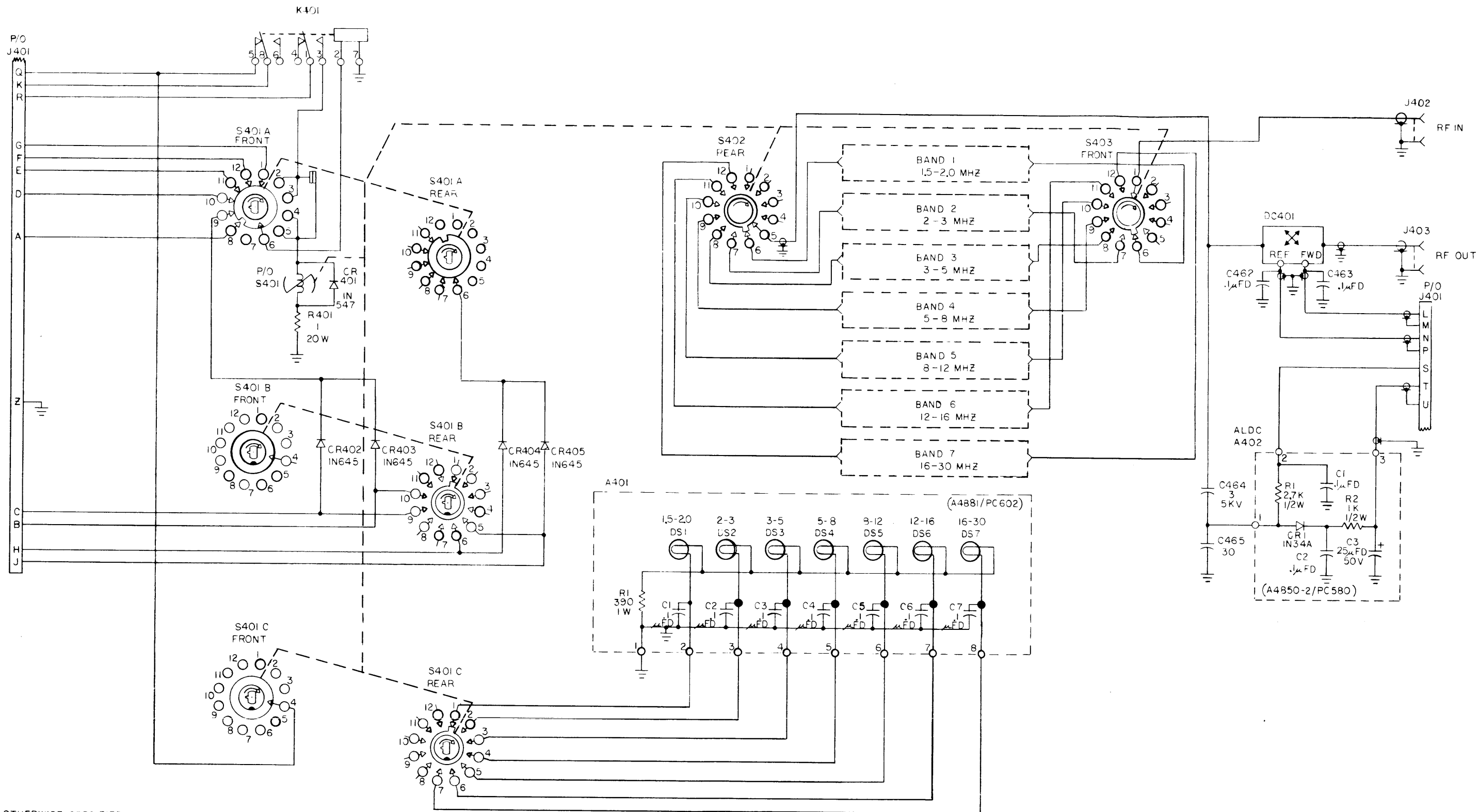

UNLESS OTHERWISE SPECIFIED:
 1. SWITCH SHOWN IN POSITION 1, BAND 1.
 2. RESISTANCES ARE IN OHMS.
 3. CAPACITANCES ARE IN PICO-FARADS.
 4. PARTIAL REFERENCE DESIGNATIONS ARE SHOWN.
 FOR COMPLETE DESIGNATION, PREFIX WITH THE
 SUB-ASSEMBLY DESIGNATION.

LAST SYMBOLS		
400 SERIES	A401 SERIES	
A402	XK401	C7
C465		DS7
CR405		E8
DC401		R1
J403		
K401		
L421		
R401		
S403		

(CK1882A)

Figure 7-1. Schematic Diagram TFP-1K
 (Sheet 1 of 2)

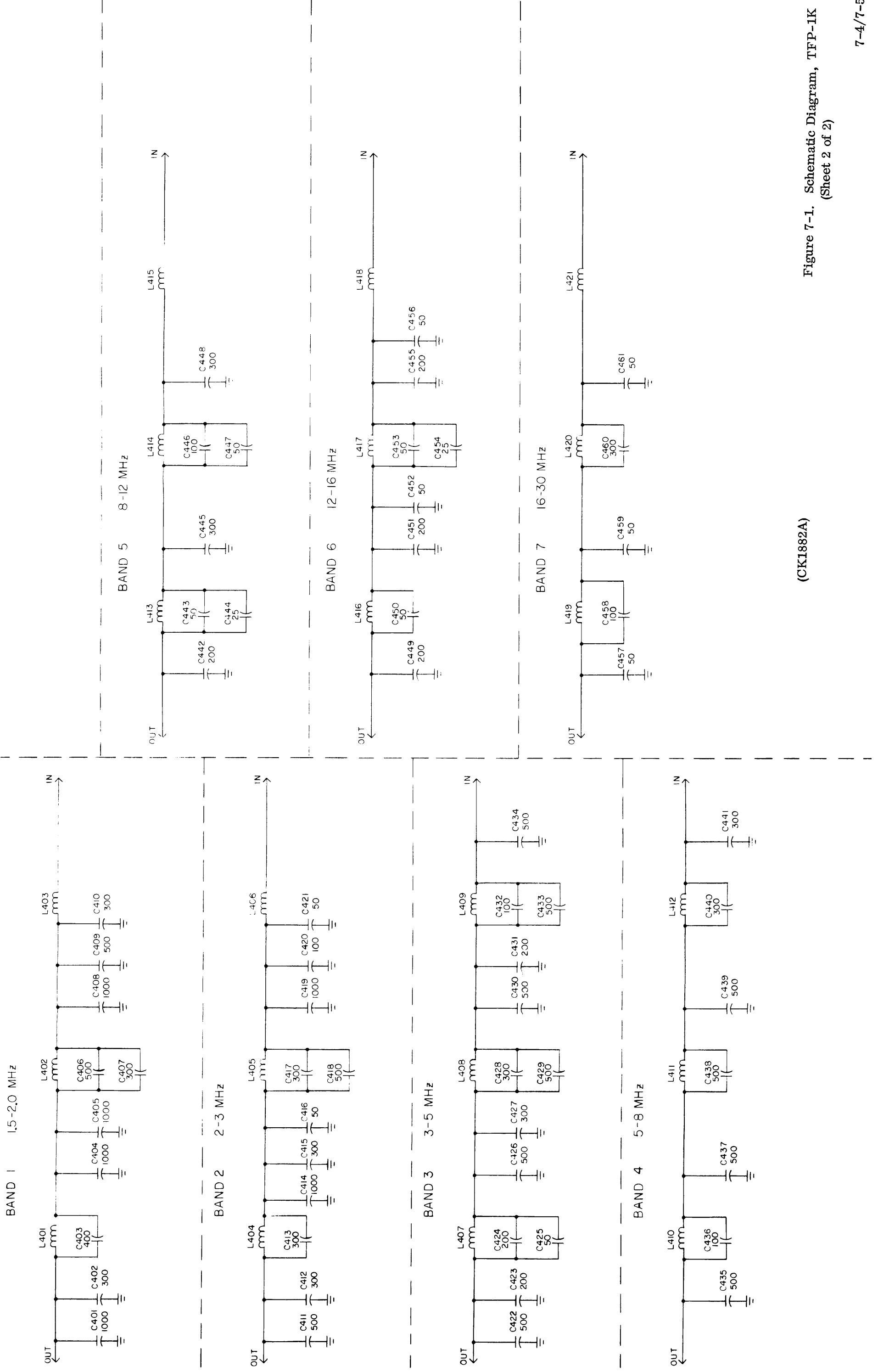

(CK1882A)

Figure 7-1. Schematic Diagram, TFP-1K
(Sheet 2 of 2)

BAND 1 1.5-2.0 MHz

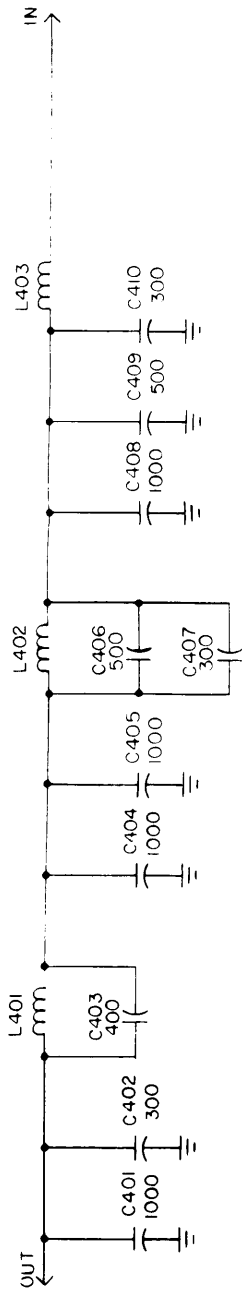

BAND 2 2-3 MHz

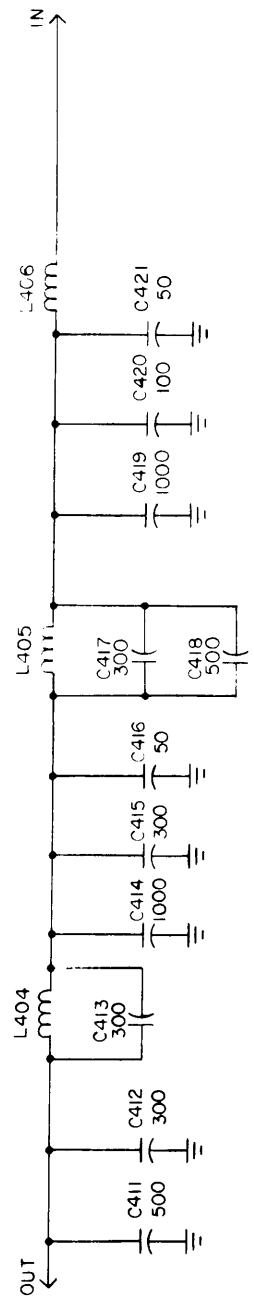

BAND 3 3-5 MHz

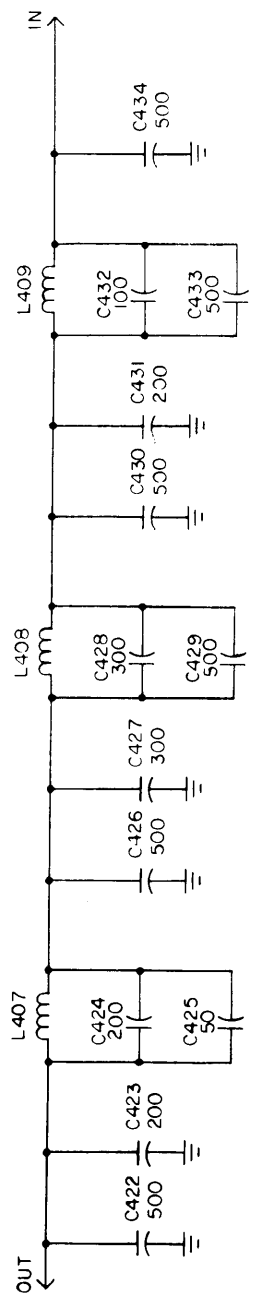

BAND 4 5-8 MHz

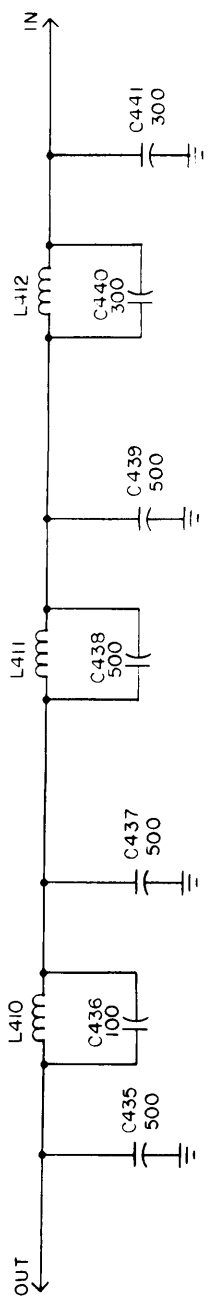

BAND 5 8-12

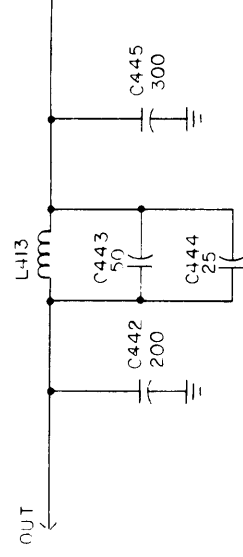

BAND 6 12-16

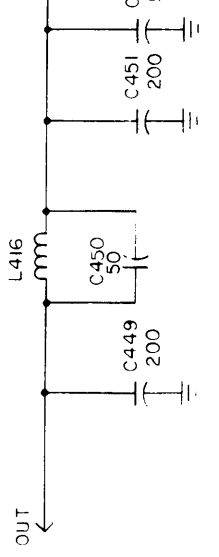

BAND 7 16-30

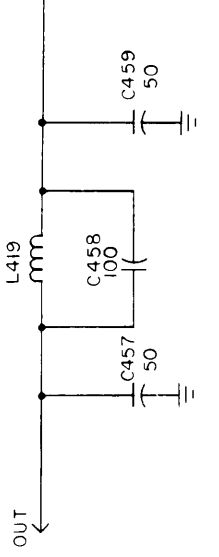

(CK1882A)