

MASTER COPY
DO NOT DESTROY

TECHNICAL MANUAL

for

COASTAL HARBOR RADIO TRANSMITTING

SYSTEM MODEL SYM 1202

FOR

STATION KTJ

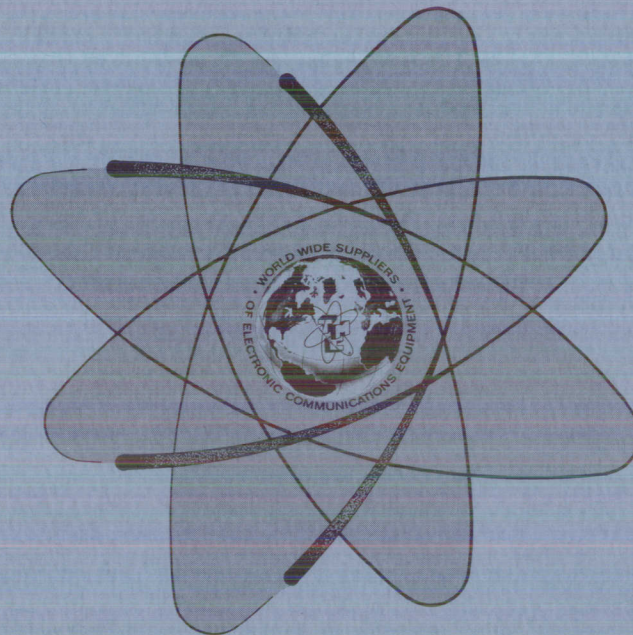

THE TECHNICAL MATERIEL CORPORATION
MAMARONECK, N.Y.

OTTAWA, ONTARIO

TECHNICAL MANUAL
for
COASTAL HARBOR RADIO TRANSMITTING
SYSTEM MODEL SYM 1202
FOR
STATION KTJ

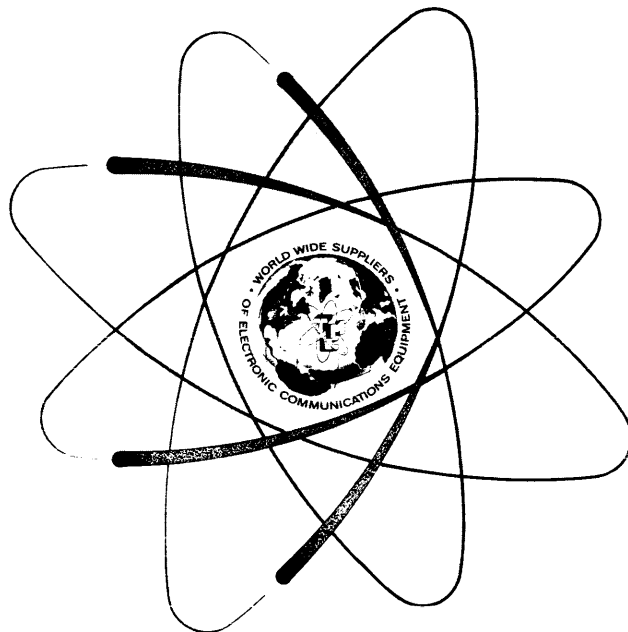

THE TECHNICAL MATERIEL CORPORATION
MAMARONECK, N.Y. OTTAWA, ONTARIO

COPYRIGHT 1971
THE TECHNICAL MATERIEL CORPORATION

Printed in U.S.A.

IN 1062

Issue Date: AUGUST 27, 1971

NOTICE

THE CONTENTS AND INFORMATION CONTAINED
IN THIS INSTRUCTION MANUAL IS PROPRIETARY
TO THE TECHNICAL MATERIEL CORPORATION
TO BE USED AS A GUIDE TO THE OPERATION
AND MAINTENANCE OF THE EQUIPMENT FOR
WHICH THE MANUAL IS ISSUED AND MAY NOT
BE DUPLICATED EITHER IN WHOLE OR IN
PART BY ANY MEANS WHATSOEVER WITHOUT
THE WRITTEN CONSENT OF THE TECHNICAL
MATERIEL CORPORATION.

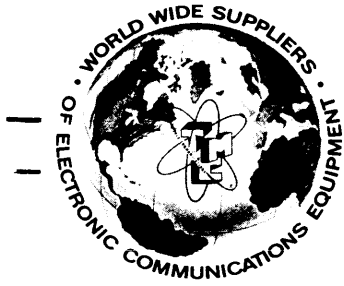

THE TECHNICAL MATERIEL CORPORATION

C O M M U N I C A T I O N S E N G I N E E R S

700 FENIMORE ROAD

MAMARONECK, N. Y.

W a r r a n t y

The Technical Materiel Corporation, hereinafter referred to as TMC, warrants the equipment (except electron tubes,*fuses, lamps, batteries and articles made of glass or other fragile or other expendable materials) purchased hereunder to be free from defect in materials and workmanship under normal use and service, when used for the purposes for which the same is designed, for a period of one year from the date of delivery F.O.B. factory. TMC further warrants that the equipment will perform in a manner equal to or better than published technical specifications as amended by any additions or corrections thereto accompanying the formal equipment offer.

TMC will replace or repair any such defective items, F.O.B. factory, which may fail within the stated warranty period, PROVIDED:

1. That any claim of defect under this warranty is made within sixty (60) days after discovery thereof and that inspection by TMC, if required, indicates the validity of such claim to TMC's satisfaction.
2. That the defect is not the result of damage incurred in shipment from or to the factory.
3. That the equipment has not been altered in any way either as to design or use whether by replacement parts not supplied or approved by TMC, or otherwise.
4. That any equipment or accessories furnished but not manufactured by TMC, or not of TMC design shall be subject only to such adjustments as TMC may obtain from the supplier thereof.

Electron tubes*furnished by TMC, but manufactured by others, bear only the warranty given by such other manufacturers. Electron tube warranty claims should be made directly to the manufacturer of such tubes.

TMC's obligation under this warranty is limited to the repair or replacement of defective parts with the exceptions noted above.

At TMC's option any defective part or equipment which fails within the warranty period shall be returned to TMC's factory for inspection, properly packed with shipping charges prepaid. No parts or equipment shall be returned to TMC, unless a return authorization is issued by TMC.

No warranties, express or implied, other than those specifically set forth herein shall be applicable to any equipment manufactured or furnished by TMC and the foregoing warranty shall constitute the Buyers sole right and remedy. In no event does TMC assume any liability for consequential damages, or for loss, damage or expense directly or indirectly arising from the use of TMC Products, or any inability to use them either separately or in combination with other equipment or materials or from any other cause.

*Electron tubes also include semi-conductor devices.

PROCEDURE FOR RETURN OF MATERIAL OR EQUIPMENT

Should it be necessary to return equipment or material for repair or replacement, whether within warranty or otherwise, a return authorization must be obtained from TMC prior to shipment. The request for return authorization should include the following information:

1. Model Number of Equipment.
2. Serial Number of Equipment.
3. TMC Part Number.
4. Nature of defect or cause of failure.
5. The contract or purchase order under which equipment was delivered.

PROCEDURE FOR ORDERING REPLACEMENT PARTS

When ordering replacement parts, the following information must be included in the order as applicable:

1. Quantity Required.
2. TMC Part Number.
3. Equipment in which used by TMC or Military Model Number.
4. Brief Description of the Item.
5. The *Crystal Frequency* if the order includes crystals.

PROCEDURE IN THE EVENT OF DAMAGE INCURRED IN SHIPMENT

TMC's Warranty specifically excludes damage incurred in shipment to or from the factory. In the event equipment is received in damaged condition, the carrier should be notified immediately. Claims for such damage should be filed with the carrier involved and not with TMC.

All correspondence pertaining to Warranty Claims, return, repair, or replacement and all material or equipment returned for repair or replacement, within Warranty or otherwise, should be addressed as follows:

THE TECHNICAL MATERIEL CORPORATION
Engineering Services Department
700 Fenimore Road
Mamaroneck, New York

SECTION 1

GENERAL INFORMATION

1-1. FUNCTIONAL DESCRIPTION

This manual presents system instructions for Radio Transmitting System Model SYM-1202. Included are general descriptions of the equipment, installation and operating procedures; principles of operation and troubleshooting data.

Radio Transmitting System, Model SYM-1202 (figure 1-1), hereinafter referred to as system, consists of two Sideband Strip Exciters Model STE-5A used in conjunction with two 500 watt Linear Amplifiers, Model PAL-500. The combination of Models STE-5A and PAL-500 is commonly known as the Model GPT-500YA Transmitter. Therefore, the System 1202 is essentially two complete 500 watt transmitting systems housed in a single equipment rack. The exciters provide PTT A3H, PTT A3J and PTT A3A modes of emission. The Linear Power Amplifiers amplify the exciter output to provide 500 watts output at carrier frequencies of 2182.0 kHz and/or 2566.0 kHz. Additionally, the SYM-1202 provides remote control of the linear amplifier primary power ON/OFF, and remote selection of transmitter emission modes.

Table 1-1 lists the system components as they appear in figure 1-1.

TABLE 1-1. COMPONENTS OF RADIO SYSTEM SYM-1202

<u>Nomenclature</u>	<u>Common Name</u>
QDP-7ALX8	Patch Panel
RFE-1	Linear Amplifier
STE-5A	Sideband Strip Exciter
RFE-1	Linear Amplifier
STE-5A	Sideband Strip Exciter
PSP-500	Power Supply
AX5135	Remote Power Control Unit
PSP-500	Power Supply
AX5135	Remote Power Control Unit

1-2. PHYSICAL DESCRIPTION

As shown in figure 1-1, the system consists of a single equipment cabinet 72 inches high by 20-5/8 inches wide by 22-1/2 inches deep, which houses all the components which comprise the SYM-1202. Primary power connections are made at AC jack, located in the rear of the equipment cabinet. RF power is routed through Low Pass filter LPF-750-3 to output connector J2 and re-routed to patch panel QDP-7ALX8, located in the upper rear portion of the equipment cabinet. The GPT-500YA components (STE-5A and PAL-500) are slide mounted into the equipment cabinet for easy access and maintenance purposes.

1-3. REFERENCE DATA

The Transmitting System, Model SYM-1202 consists of two model GPT-500YA Transmitters which are FCC type accepted under part 81 and is type approved by the Department of Transport in Canada, refer to the Technical Manual for the GPT-500YA for technical specifications.

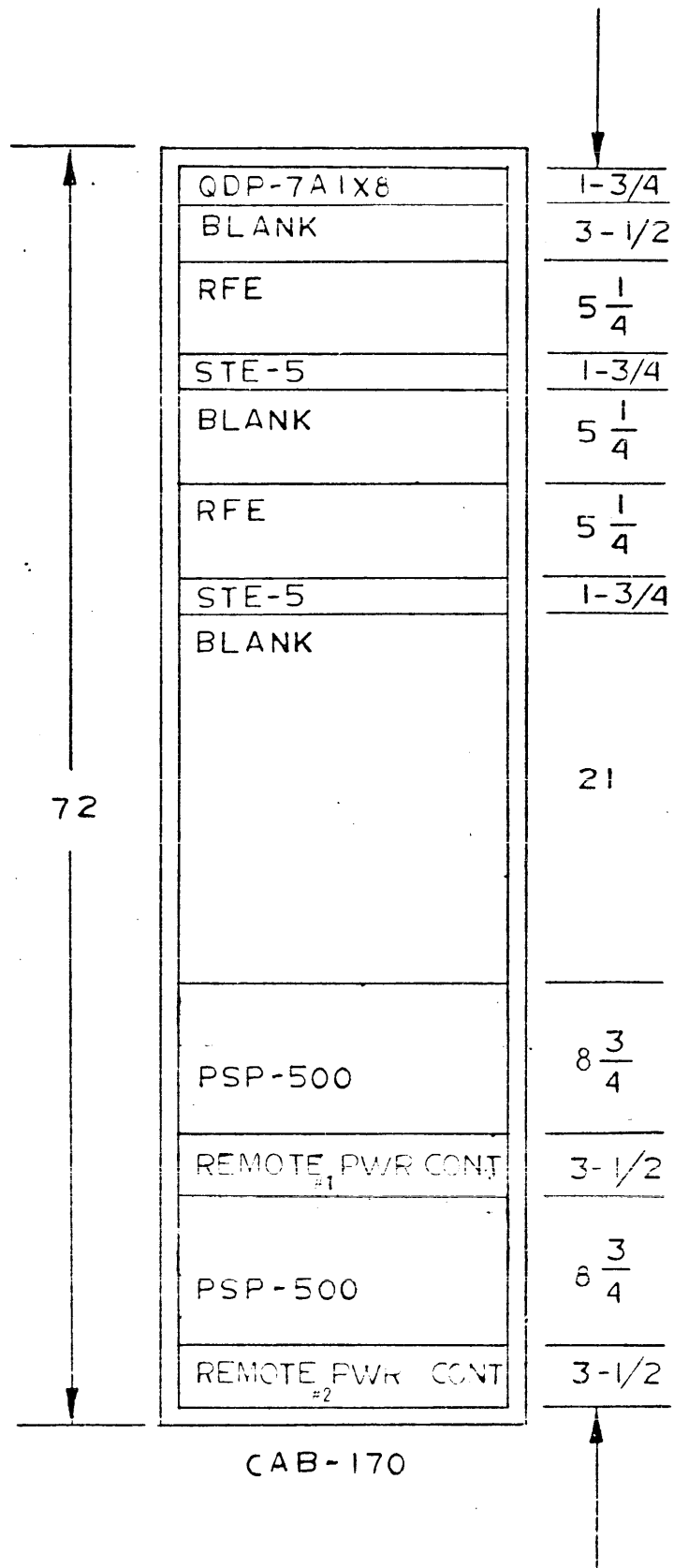

NOTE : AF AND RF ACCESS THROUGH TOP OF RACK.
 (SEE CUSTOMER EQUIPMENT SPEC 8.02,
 DATED 3-15-71 FOR DETAILS. SO.518810)

Figure 1-1. Component Location Drawing

SECTION 2

INSTALLATION

2-1. UNPACKING AND HANDLING

The SYM-1202 Transmitter System is shipped in boxes as shown by (figures 2-1 and 2-2). The box number is stenciled on the outside of each box and the contents are listed on the packing list. Inspect all boxes for possible damage when they arrive at the operating site. With respect to equipment damage for which the carrier is liable, The Technical Materiel Corporation will assist in describing methods of repair and the furnishing of replacement parts.

Inspect the contents of each box for possible damage and inspect the packing material for parts that may have been shipped as loose items.

2-2. POWER REQUIREMENTS

All units of the System leave the factory wired for 115 volt, 50/60 cycle, single phase line voltage unless ordered otherwise. Power consumption of the system is approximately 2300 watts (1150 watts for each GPT-500); power cabling of sufficient size to provide 30 amperes at 115 volts ac, single phase, is adequate.

2-3. INSTALLATION

a. Location of Transmitter - Before attempting to install the SYM-1202 ensure that adequate power (paragraph 2-2) is available at the selected site or location. Refer to outline dimensional drawing figure 2-3 when choosing the operating location. The room (or van) in which the transmitter is located must have a ceiling height of at least 7 feet. Adequate ventilation must be provided; operation of the transmitter in a poorly ventilated room will cause the surrounding temperature to become too high. Also, a clearance of about two feet at the rear of the rack is needed for opening the door.

After unpacking and inspecting the cabinet, place it in its operating location. It is advisable to do this while modular units are not installed because the added weight of the assembled transmitter will make movement more difficult. The four holes in the top of the rack and the four eyebolts included as loose parts in the shipment are for moving the rack with a crane hoist. Holes in the base are for rigid-mounting or shock mounting the rack to the floor. Holes along the top of the rear wall are for the top shock mounts. Use these holes as a template for drilling holes in the shelter or van.

NOTE

When equipment is to be shock mounted, a shock mounting kit and separate installation instructions are supplied.

b. Installation of Modular Units - Refer to figure 1-1 for information regarding cabinet location of all modular units.

All modular units are slide mounted except for Patch Panel QDP-7A1X8, Remote Power Control Unit AX5135. Remote Power Control Unit AX5135 is installed in the rack prior to shipment. To install any slide-mounted unit in its compartment refer to figure 2-4 and proceed as follows:

- (1) Untape or unstrap cable assemblies and all other components secured to the rack frame for shipment.
- (2) Pull center section of associated compartment track out until it locks in an extended position.
- (3) Position slide mechanisms of modular unit in tracks, and ease modular unit forward into rack until release buttons engage hole in track.
- (4) Start at the bottom and proceed up to prevent the rack from tipping over.
- (5) Make the necessary cable and electrical connections as described in paragraph 2-3c. To prevent the cables extending from modular units from snagging, utilize the reel-mounted springs located inside the rack.
- (6) Depress release buttons and slide modular unit completely into compartment.
- (7) Secure front panel of modular unit to the rack with screws.

c. Interconnection of Modular Units - Figure 2-5 illustrates the cabling and wiring interconnection between the various modular units contained in the system. Refer to figure 2-5 and connect modular units as indicated.

d. Initial Adjustments - The SYM-1202 has been factory tested and adjusted before disassembly for crating. No initial adjustments of chassis mounted variable components are necessary before operation.

e. External Connections to SYM-1202

(1) Remote Power control Voltage - Remote power control voltage connections are provided at terminal board TB2 located on the right wall of the equipment cabinet. The control voltage required is -48 vdc. Connect -48 vdc to TB2 terminals 5 and 6 for Remote Power Control Unit 1. Connect -48 vdc to TB2 terminal 7 and 8 for Remote Power Control Unit 2.

NOTE

Remote Power Control unit 1 controls the application of primary power to transmitter 1.

(2) The primary AC input connection is provided at the rear of the equipment cabinet. Terminate the ac input cable with AC plug (PL-190-NG) supplied as a loose item and connect to J1 located at the rear bottom portion of the equipment cabinet. Bear in mind that when the primary ac is connected to the equipment cabinet, only the exciter units (STE-5A) will receiver power.

Power to the linear amplifier portion of the system is applied via Remote Power Control Unit AX5135, only when the -48 vdc remote line voltage is applied to terminal board TB-2 (located on right wall inside of cabinet) terminals 5 and 6, 7 and 8.

NOTE

Cable entry holes are provided at the top of the equipment cabinet for 600 ohm audio lines, remote emission mode select and RF Output. Determine required length and route cables through cable entry holes and connect as indicated below.

(3) Audio Input Connections - Provide two separate 600 ohm lines (shielded pairs) one audio line for each sideband exciter and connect lines to terminal board TB1501 terminals 1, 2, 3 located on the rear of each STE-5A exciter unit. Terminals 1, 2 and 3 on TB1501 are the 600 ohm balanced audio input terminals.

(4) Remote Mode Selection - Remote mode selection is accomplished in the STE-5A exciters when external connections are made to terminal board TB1501. The external connections are merely contact closures and may be completed via switches or pushbuttons. The remote mode connections are as follows:

for A3H operation short TB1501 7 to 5
for A3A operation short TB1501 7 to 6
for A3J operation short TB1501 7 to 12

(5) External RF Output Indication - RF Output Indicator AX5137 provides a contact closure for an indicating device when the transmitted power is at a pre-determined output level. Connect indicator lines on TB2 (located on cabinet wall) terminals 1 and 2 for Output Indicator 1 and terminals 3 and 4 for output indicator 2.

(6) RF Power Output Connection - Transmitter RF power is routed from each Linear amplifier through separate low pass filters and terminated at patch panel QDP-7A1X8. Antenna connections for each transmitter within the system consists of connecting the transmission line to the appropriate connector on the patch panel.

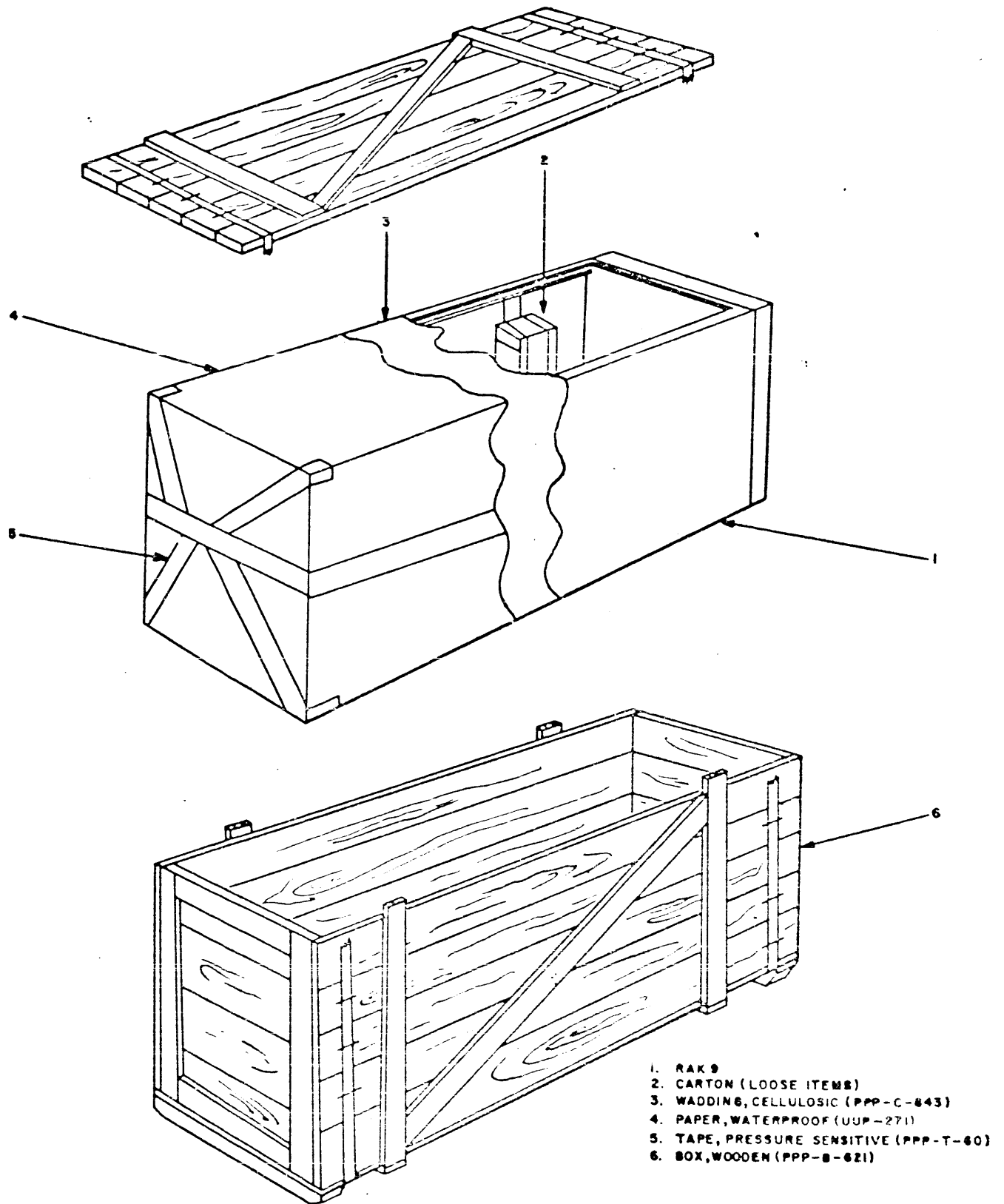

Figure 2-1. Rack, Preparation for Shipment

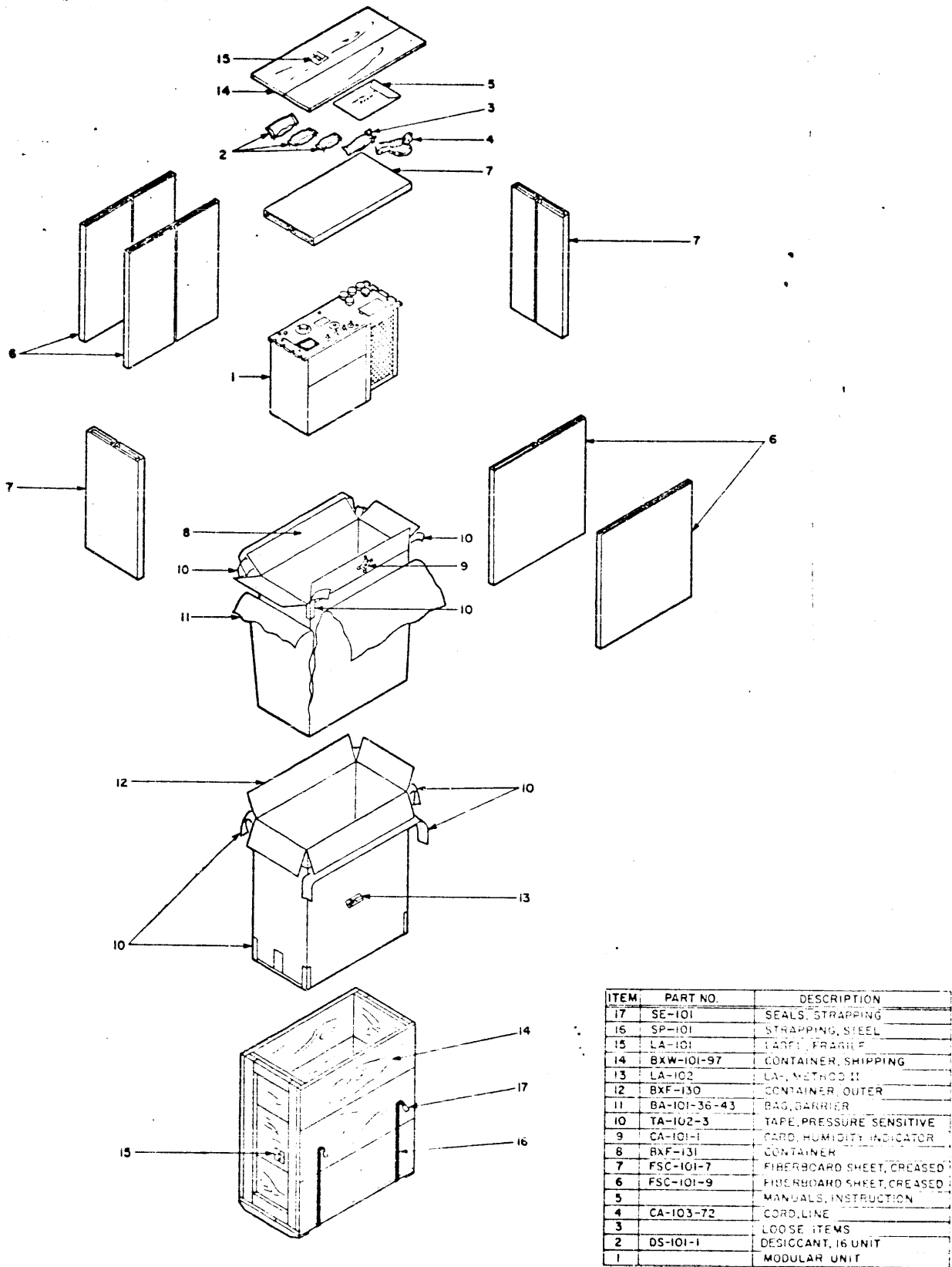

Figure 2-2. Modular Units, Preparation for Shipment Typical

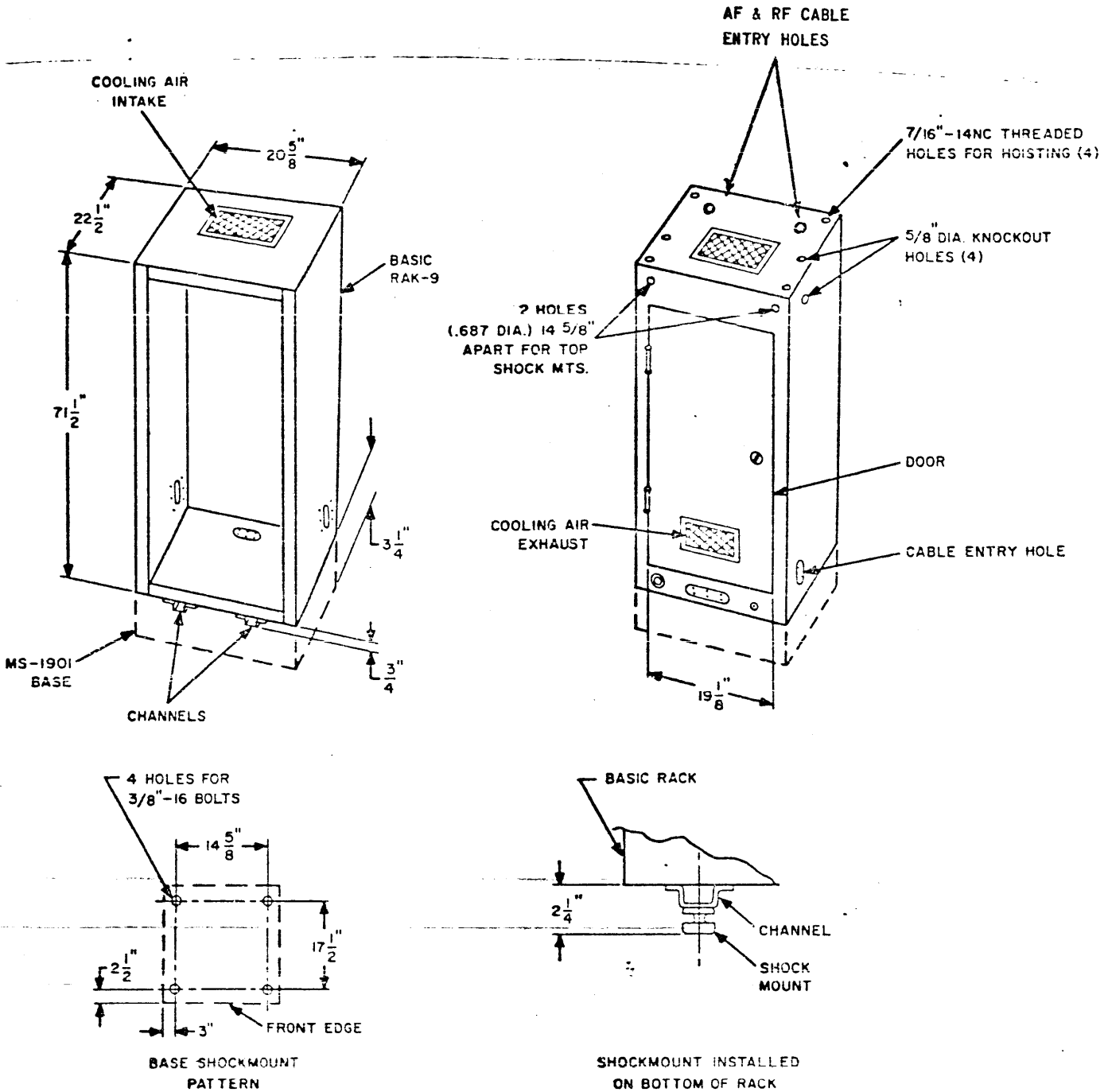
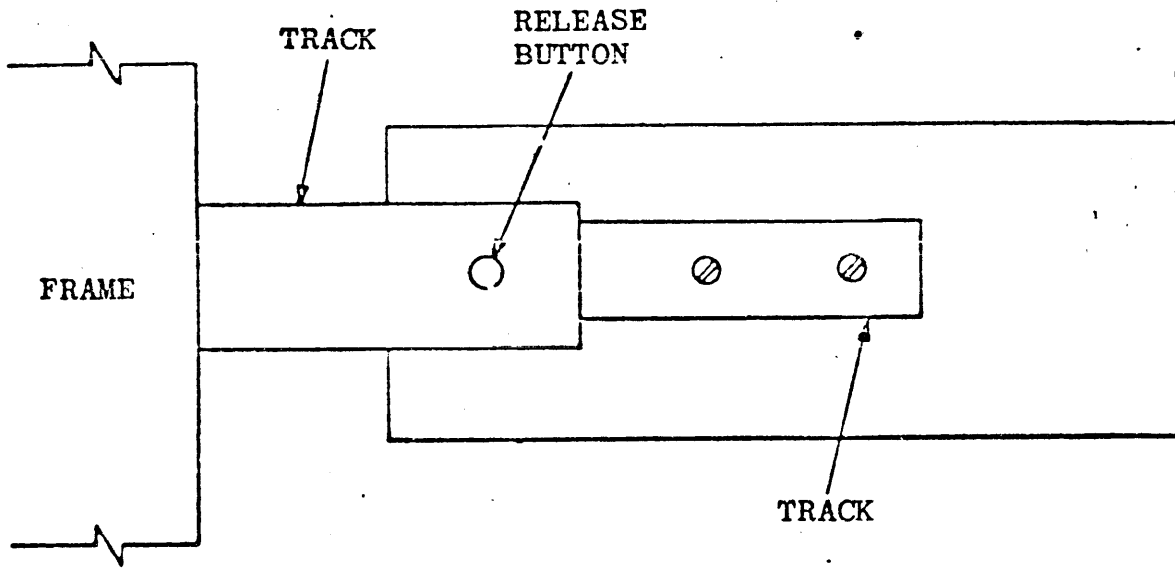
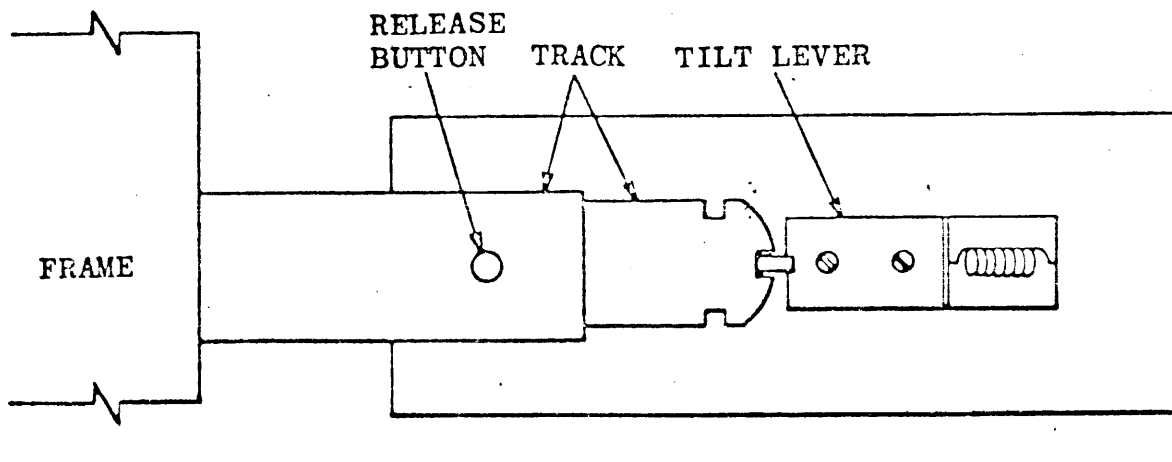

Figure 2-3. Outline Dimensional and Installation Drawing



NON-TILT CHASSIS SLIDE



TILT CHASSIS SLIDE

Figure 2-4. Slide-Mounting Details

B

QDP-7AIX8

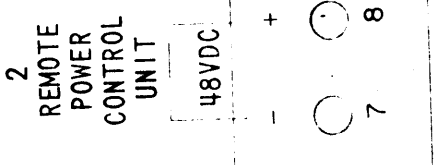
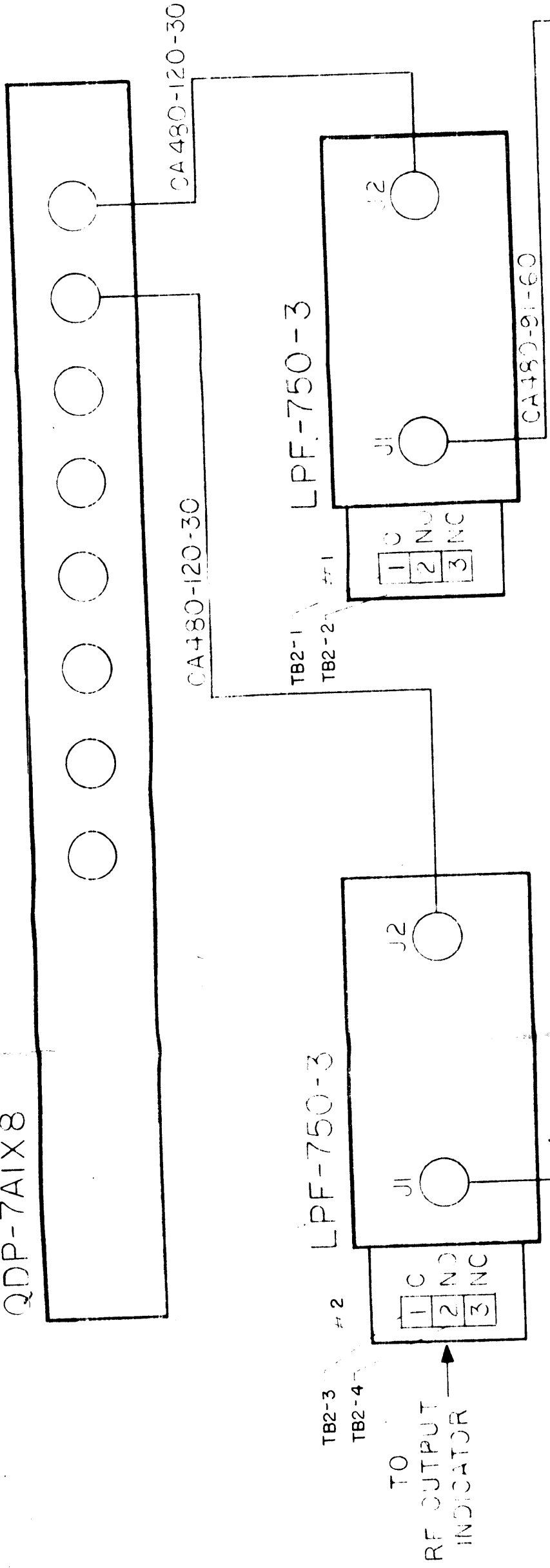

RFE-1

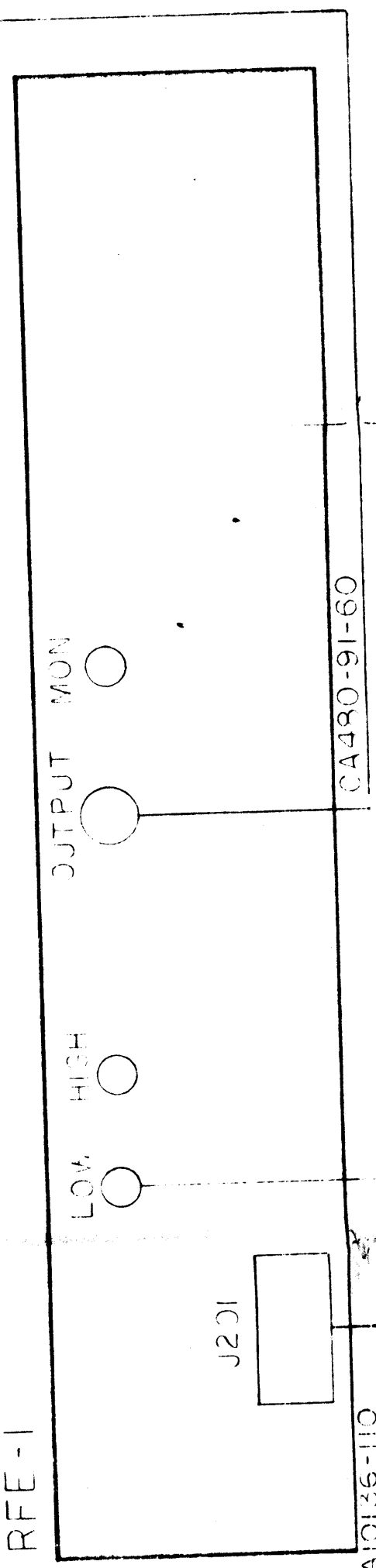

ED IN THE EQUIPMENT CABINET
MED FROM THE REAR OF THE

STE-5A

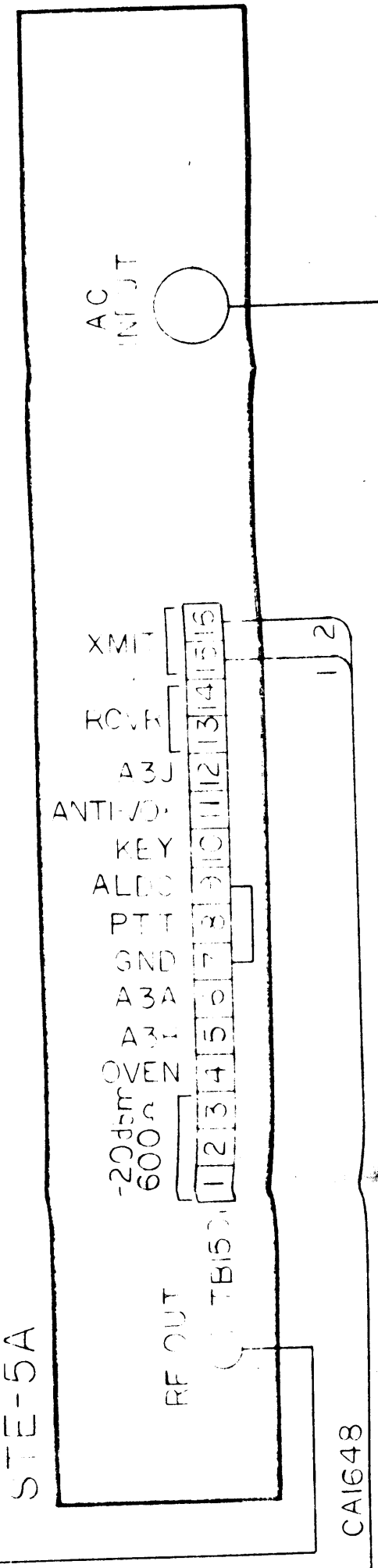

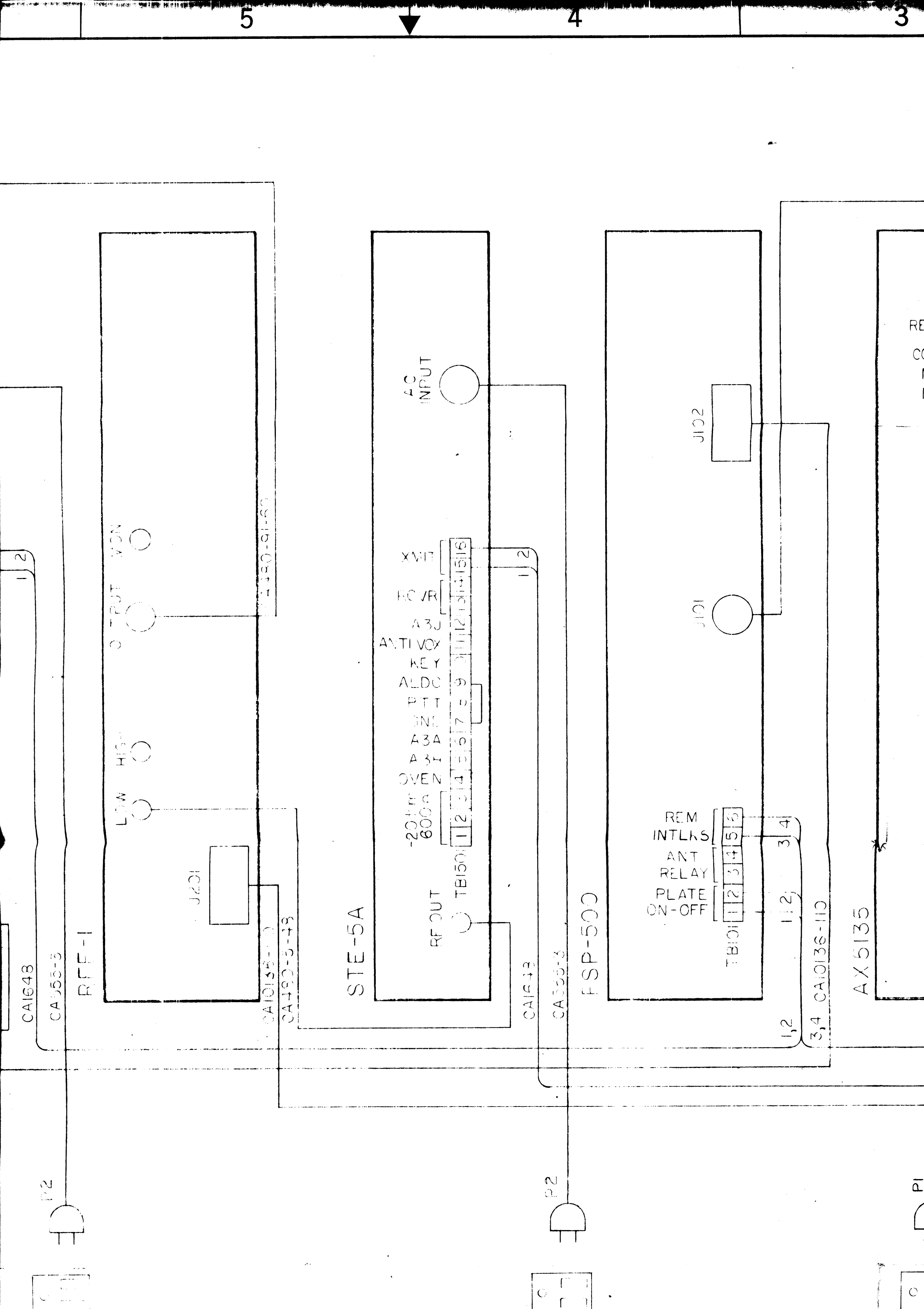

REVISIONS					DATE	APPROVED
E.M.N.NO	DRAFT	CHKD	ZONE	LTR	DESCRIPTION	

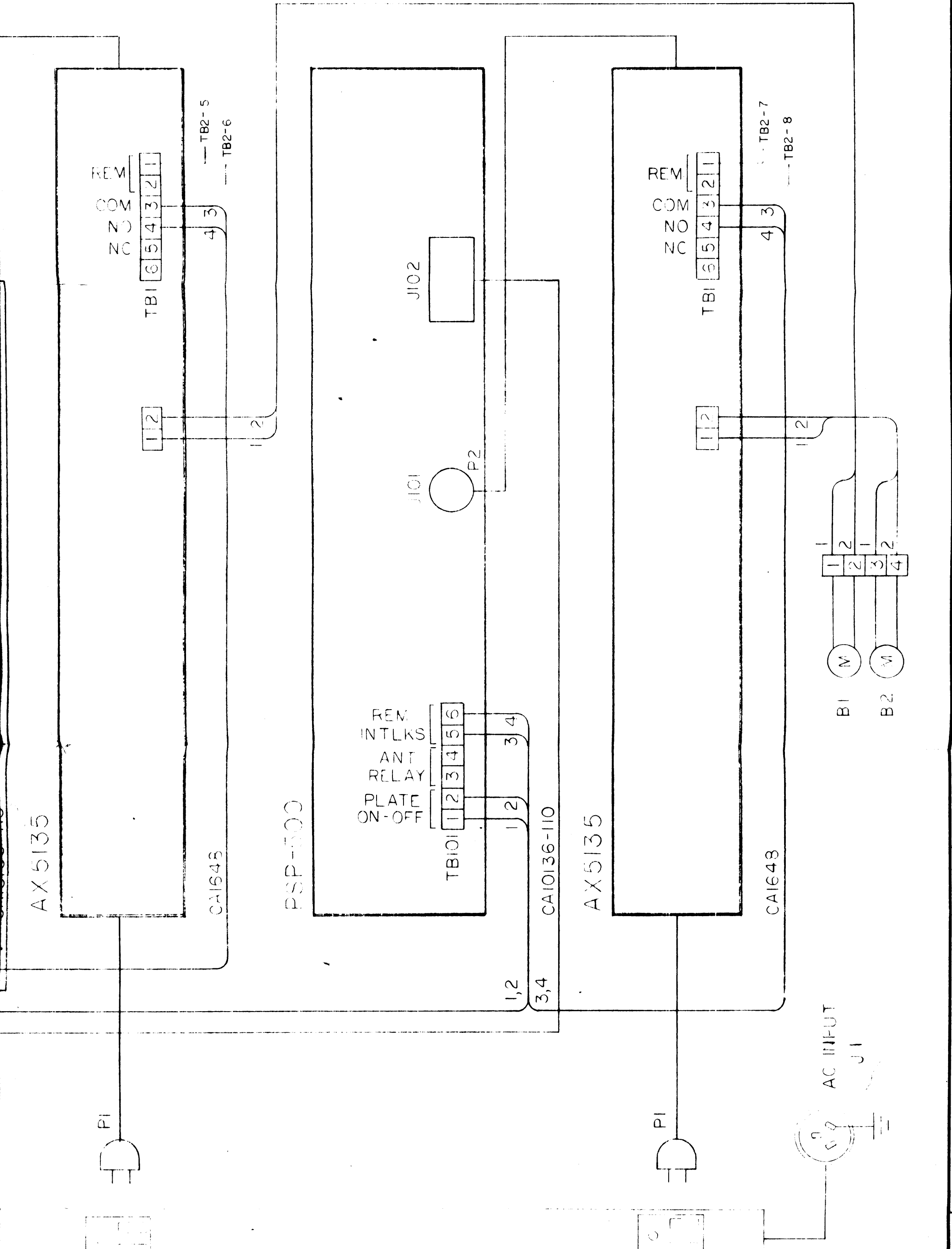

D

C

B

1061X0

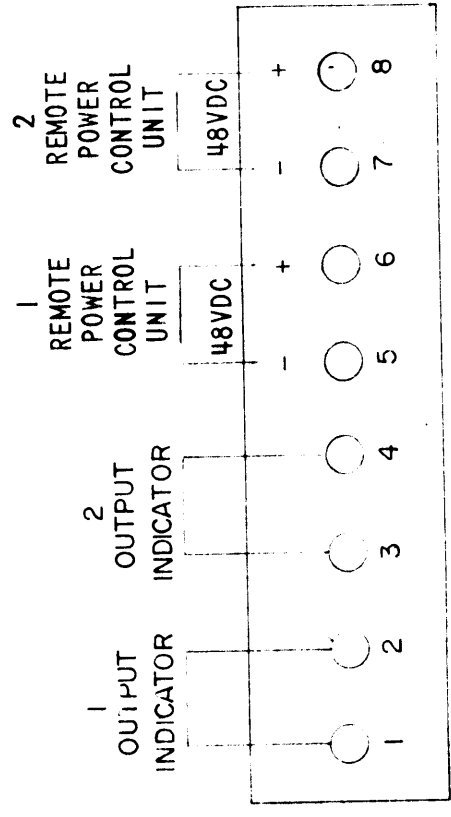
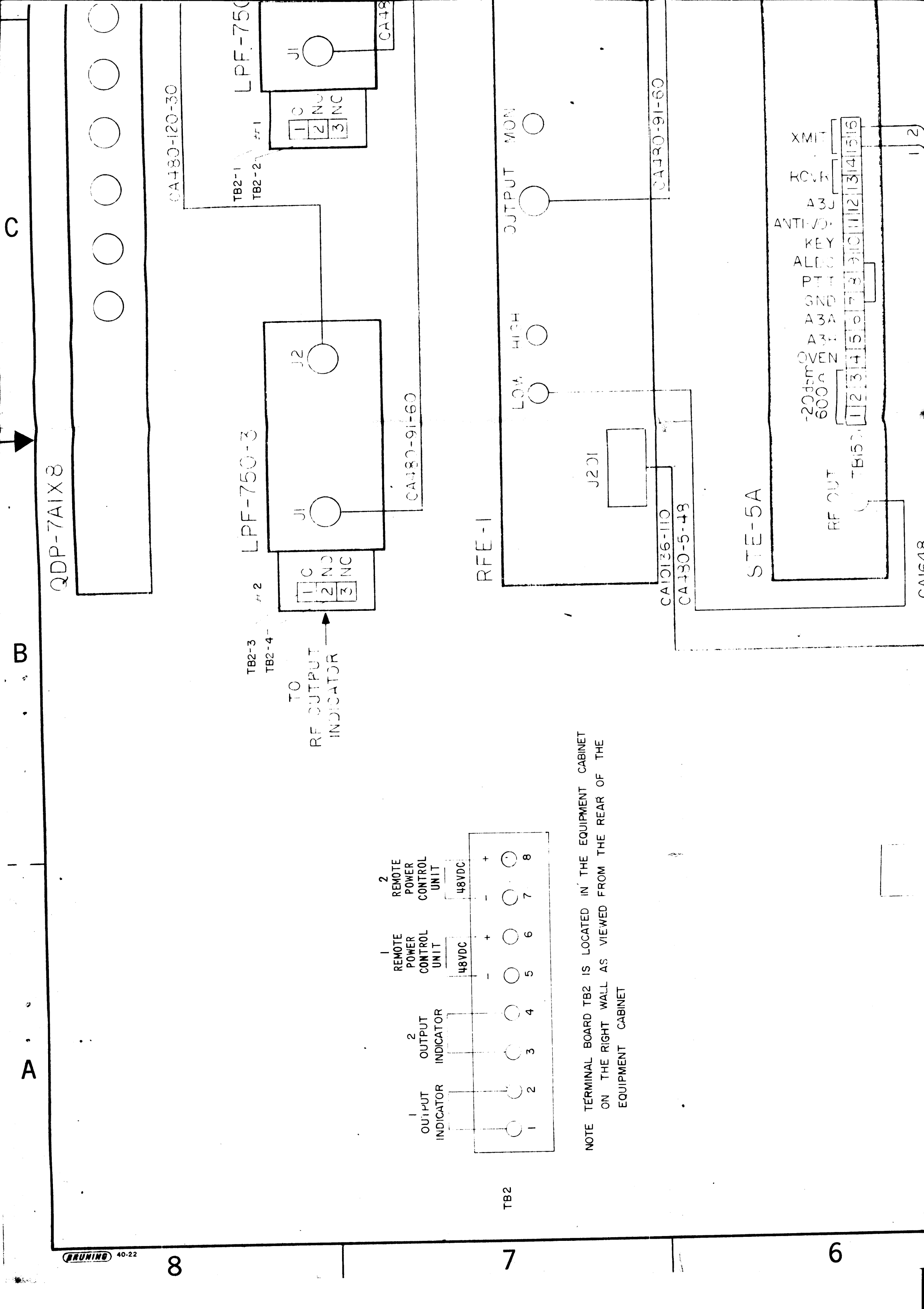

NOTE TERMINAL BOARD TB2 IS LOCATED IN THE EQUIPMENT CABINET ON THE RIGHT WALL AS VIEWED FROM THE REAR OF THE EQUIPMENT CABINET

QDP-7A1X8

LPF-750-3

RFE-1

STE-5A

CA480-120-30

CA480-91-60

CA10136-110
CA480-5-48

CA480-91-60

TB2-1
TB2-2

TB2-3
TB2-4

TO
RF OUTPUT
INDICATOR

TB15
1 2 3 4 5 6 7 8 9 10 11 12 13 14 15 16
RF OUT
-20dBm
600Ω
OVEN
A3A
A3B
GND
PTT
ALEDC
KEY
ANTI-VO
A3J
RCVR
XMIT

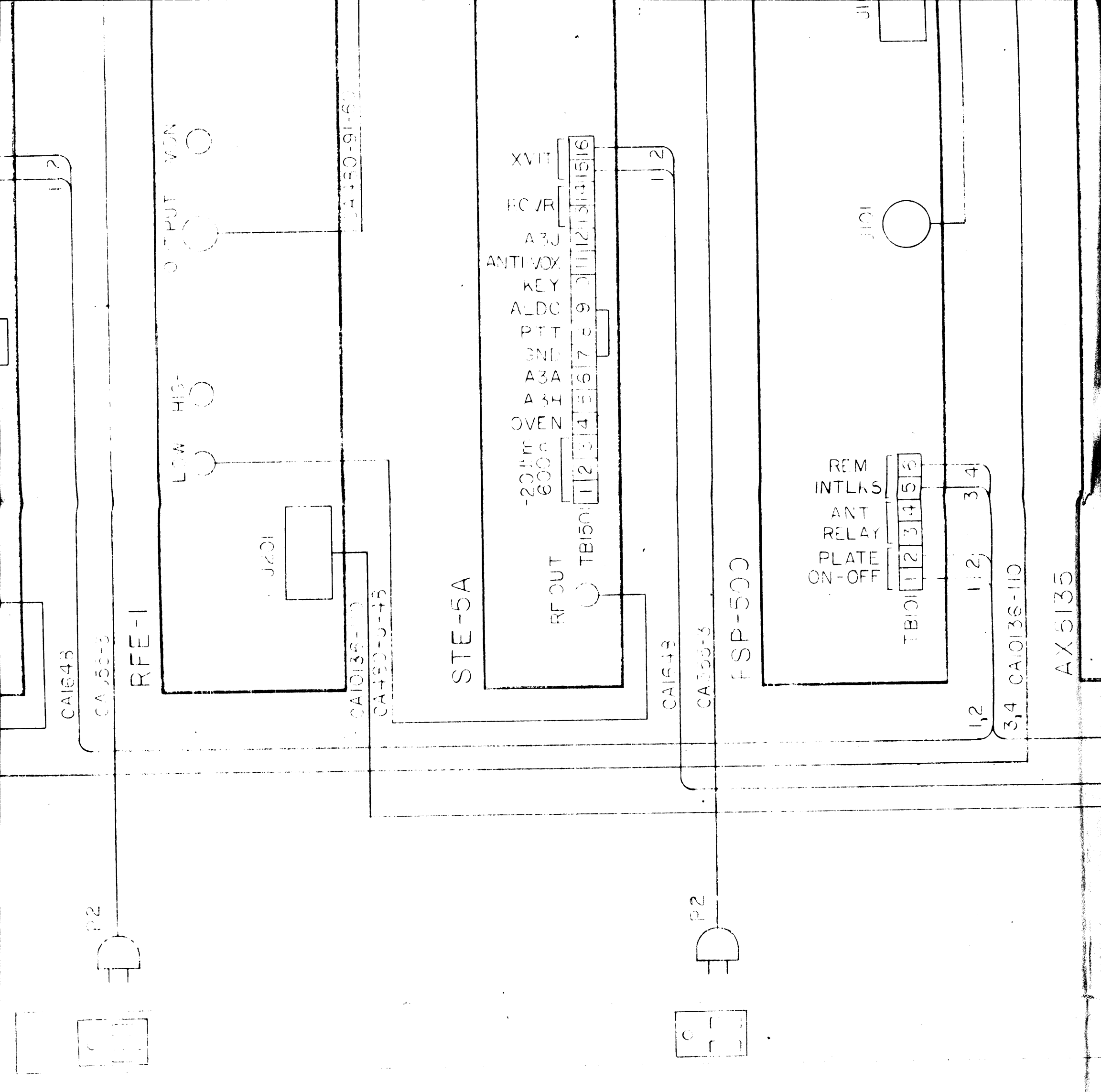

STANDARD
AC
STRIP
CUT
BY
FILE

SYM 1202		
QTY / UNIT	MODEL USED ON	ASS'Y NO.
APPLICATION		
	CODE	
<p>NOTICE TO PERSONS RECEIVING THIS DRAWING THE TECHNICAL MATERIEL CORPORATION claims proprietary right in the material disclosed hereon. This drawing is issued in confidence for engineering information and may not be reproduced or used to manufacture anything shown hereon without permission from THE TECHNICAL MATERIEL CORPORATION to the user. This drawing is loaned for mutual assistance and is subject to recall at any time.</p>		

5



4

UN
D
AND
DE
J
MA
FIN

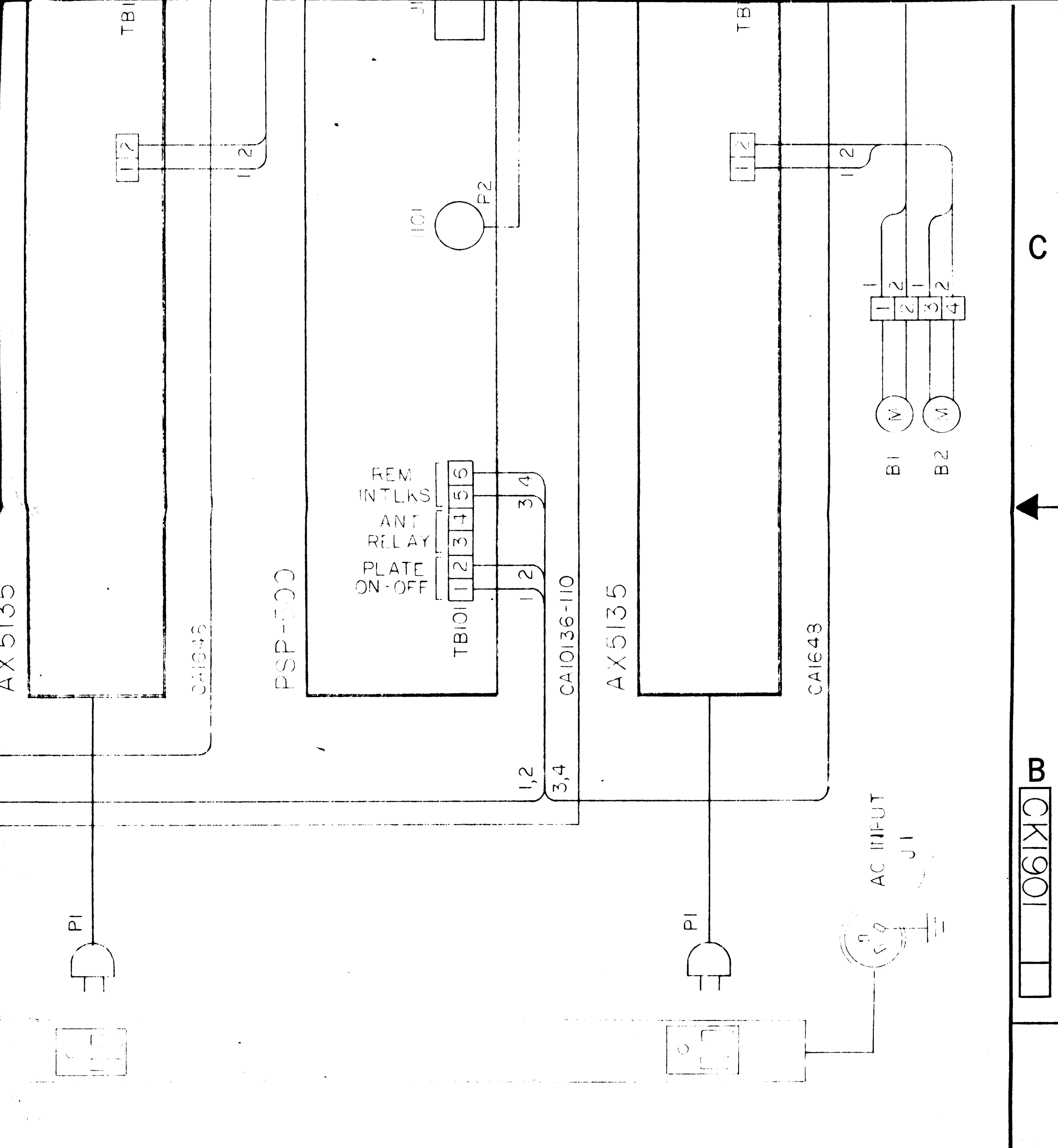

C ←

B

CK1901

QTY. REQ.	ITEM	PART NO.	DESCRIPTION	SYMBOL
LIST OF MATERIAL				
UNLESS OTHERWISE SPECIFIED DIMENSIONS ARE IN INCHES AND INCLUDE CHEMICALLY APPLIED OR PLATED FINISHES		FINAL APPROVAL <i>[Signature]</i>	DATE 20 Aug 71	THE TECHNICAL MATERIEL CORP. MAMARONECK, NEW YORK Figure 2-5 Wiring Diagram of SYM1202
TOLERANCES ON		MECH. DES.	DATE	
DECIMALS	FRACTIONS	ELECT. DES. <i>[Signature]</i>	DATE 20 Aug 71	
.X ± .05	± 1/64	CHECKED	DATE	
.XX ± .01	ANGLES	DRAWN <i>[Signature]</i>	DATE 23 Jul 71	
.XXX ± .005	± 0° -30'			
MATERIAL		SIZE	CODE IDENT NO.	DWG NO.
FINISH		D	82679	CK1901
		SCALE		SHEET OF

A

1

2

3

SECTION 3

OPERATOR'S SECTION

3-1. GENERAL

The Radio Transmitting System, SYM-1202 is capable of supplying up to 500 watts PEP from each GPT-500YA transmitter within the SYM-1202 system for transmission on two separate unbalanced antennas or dummy load. The RF output may also be safely set to any power level below 500 watts PEP. The system RF output is controlled by the AF GAIN control on the exciter. Remote control provisions are provided for the following:

- a. Primary power ON/OFF
- b. Indication of transmit power level (by using a set of closed contacts provided for each transmitter within the SYM-1202).
- c. Control of carrier (modes - A3A, A3H or A3J) with PTT

3-2. CONTROLS AND INDICATORS

All controls and indicators for the system are located on the front panels of the modular unit except the HAND SET/LINE switch which is on the rear of the STE-5A. For a detailed description of these controls and their functions refer to the units technical manual.

3-3. OPERATING PROCEDURES

A. General - Detailed operating procedures for individual units may be found in the unit technical manuals. Before attempting to operate the system, the operator should become familiar with the controls and indicators of the individual units and the units capabilities.

To give the operator the sequence of system operation, a general operating procedure is given in paragraph B.

B. Starting Procedure:

1. Application of Primary Power to Linear Amplifiers.

(a) Apply remote power control voltage (-48 vdc) to terminal board TB-2 terminals 5 and 6 for transmitter 1.

(b) Apply remote power control voltage (-48 vdc) to terminal board terminals 7 and 8 for transmitter 2.

2. Controls and Indicator Settings.

(a) Set AF GAIN control to off (disconnects power to exciter).

(b) Set MODE switch to AME and select carrier level as desired via remote contacts or locally from front panel.

- (c) Set PTT/VOX switch to PTT.
- (d) Turn ANTI-VOX control maximum clockwise.
- (e) Turn VOX-GAIN control maximum counter clockwise.
- (f) H.V. LINE breaker to OFF.
- (g) TRANSMITTER PLATES switch to STANDBY/REMOTE.
- (h) Turn PA TUNING control to 0.
- (i) Turn PA LOADING control to 0.
- (j) Set MAIN LINE circuit breaker to ON.
- (k) Set DRIVER BAND switch to desired frequency range.
- (l) Set PA BAND switch to desired frequency range.
- (m) Set MULTIMETER switch to RF DR.
- (n) Activate push to talk and turn AF GAIN control clockwise slightly.
- (o) Set the TRANSMITTER PLATES switch to ON. (After 60 second time delay transmitter plate indicator will light.)
- (p) Adjust DRIVER TUNING for a peak on the MULTIMETER.

NOTE

Keep peaks below 20 when tuning the DRIVER
by decreasing (ccw) the AF GAIN.

- (q) Reduce exciter AF GAIN maximum ccw.
- (r) Insure that an antenna or dummy load is connected to the output.
- (s) Set H.V. LINE circuit breaker ON.
- (t) Turn AF GAIN control slowly until the PA PLATE meter indicates approximately 300 ma.
- (u) Adjust PA TUNING control for a resonant dip on the PA PLATE meter.
- (v) Adjust the PA LOADING and TUNING controls for a dip in PA PLATE current indication and until the PA LOADING control causes no further increase in PA PLATE meter indication.
- (w) Increase the AF GAIN control until the desired RF output is obtained.

- (x) Adjust TRIP control R1, (located on fixed filter, LPF-750-3) until a contact closure is present between terminals 1 and 2, on TB-2. (check contact with ohmmeter)

CAUTION

Do not exceed 340 ma for a CW signal on PA PLATE meter and 380 ma for a two tone signal.

For other modes of operation and a more detailed operating procedure refer to the individual unit technical manuals.

C. Standby Procedure

1. Turn AF GAIN maximum CCW.
2. Set TRANSMITTER PLATES switch to STANDBY/REMOTE.
3. Set H.V. LINE breaker to OFF.

D. Remote Shutdown Procedure

1. Remove remote power control voltage applied to TB-2 terminal 5 and 6 and/or terminals 7 and 8. (disconnects primary power to linear amplifiers).

E. Remote Mode Selection (Terminal board TB1501 on STE-5A)

1. Set MODE switch to AME position.
2. Provide contact closure for desired mode of emission (via switch, pushbutton, etc.) as follows: for

PTT A3H short contacts 7 to 5 on TB1501
PTT A3A short contacts 7 to 6 on TB1501
PTT A3J short contacts 7 to 12 on TB1501

SECTION 4

PRINCIPLES OF OPERATION

4-1. GENERAL

The Coastal Radio Transmitting System, SYM-1202 (Refer to figure 4-1) is a dual channel fixed frequency transmitter. The channels or carrier frequencies are determined by a plug-in module (TTRT) in each STE-5A exciter. The channel frequency is stamped on the front of the plug-in (TTRT) module.

Each Linear Amplifier section of the transmitter (model RFE-1) uses two 4CX350A tubes connected in parallel feeding a pi network. The final tubes (4CX350A) are biased to operate in class AB1.

This unit (RFE-1) will accept one of two RF inputs, a low input of 100 milliwatts or a high input of 1 watt. It will require 100 milliwatts or less to produce the 500 watt peak envelope power output.

The exciter (STE-5) RF output is transformer coupled from a 2N3553 type transistor and is capable of delivering 100 milliwatts to the power amplifier section of a transmitter.

Principles of operation are presented in detail for each major modular unit in their respective unit technical manual. In addition to the dual GPT-50QYA Transmitters, low pass filter, model LPF750-3, remote power control unit, model AX5135, and RF indicator, model AX5137 are included in the SYM-1202 Transmitting System. These additional units and assemblies are discussed in the following paragraphs only to the extent of their interrelationship to the overall system.

4-2. LOW PASS FILTER LPF750-3 (refer to Modular technical manual)

The LPF-750-3 is a low pass fixed filter which is designed to attenuate harmonics and spurious emissions above 4000 kHz. The filter will pass fundamental frequencies between 2000 kHz and 3500 kHz without appreciable loss provided the transmitter is properly terminated.

The filter is connected in the system between the PAL-500 output connector and patch panel QDP-7A1XS.

4-3. REMOTE POWER CONTROL UNIT AX5135 (refer to figure 4-2)

Remote power control unit, AX5135 provides external ON/OFF control of primary 115 vac to the PAL-500 linear amplifier. The control unit also provides the system with remote interlock closure. There are no operating controls therefore operation consists of simply applying -48 vdc at pins 5 and 6 on TB-2 and -48 vdc to terminals 7 and 8 on TB-2 for transmitter 1 and 2 respectively.

When the SYM-1202 is interconnected as shown on Wiring Diagram CK1901, 115 vac input is applied to plug P1 on the Remote Power control Unit.

This 115 vac voltage will not be applied to the linear amplifiers or the rack blowers until -48 vdc is applied between pins 5 and 6 and 7 and 8 on TB-2. TB-2 is located on the right wall of equipment cabinet. The application of -48 vdc at TB-2 pins 5, 6, 7 and 8 will cause control relay K1 on both line control units to energize, closing relay contacts 1, 3, 6 and 8. The closed relay contacts will provide a voltage path to 115 vac OUT plug P2, which is connected to ac input plug J101 of the PAL-500 power supply.

Simultaneously the voltage bearing contacts on relay K1 also provide voltage to time delay M1. Time delay M1 upon completion of its elapsed time provides a contact closure between pins 3 and 4 on TB1. Pins 3 and 4 on TB1 are interconnected to the remote interlock circuitry of the PSP-500 (p/o PAL-500).

Thus it can be seen that the application of -48 vdc controls primary ac to the linear amplifier and H.V. can not be applied until time delay M1 elapsed time is completed. (Safety interlocks must be closed before H.V. can be applied to linear amplifier).

To remove primary ac simply remove the -48 vdc control voltage and relay K1 will de-energize removing the applied 115 vac to the linear amplifier.

Bear in mind that each time the control voltage is removed and re-applied, time delay M1 must complete its elapsed time before the transmitter can be operated. (Delay time of M1 is set for 60 seconds).

4-4. RF OUTPUT INDICATOR AX5137 (refer to figure 4-3)

Output Indicator, AX5137 is connected to the input connector J1 of Low Pass Filter LPF-750-3. This assembly serves to provide contact closure to a remotely located indicating device when the transmitter provides a predetermined RF output level.

During ON THE AIR periods of transmission RF power is routed through the Low Pass Filter to the transmitting antenna via patch panel QDP-7A1X8. The RF power is sampled and routed to output indicator board A1 via pin 1, this sampled rf voltage is rectified and routed to output pin 2. The rectified voltage is then routed through trip potentiometer R1, which is connected to one side output indicator relay K1. This dc voltage energizes relay K1 and provides contact closure between pins 1 and 2, 3 and 4 on TB2 (common and normally open respectively on each output indicator unit. Trip potentiometer R1 determines the sensitivity of relay K1. (Terminal board TB2 is located on right wall inside the equipment cabinet, as viewed from the rear of cabinet).

RF INDICATOR ←

AUDIO 600Ω
A3H PTT
A3J PTT
A3A PTT

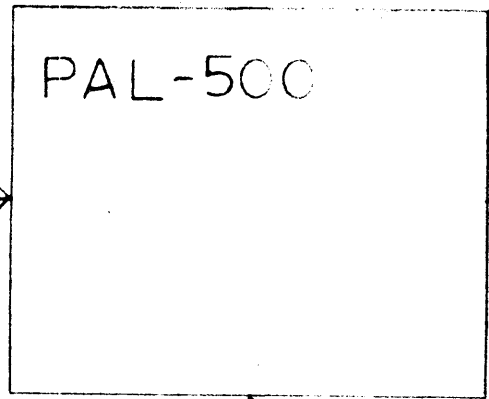
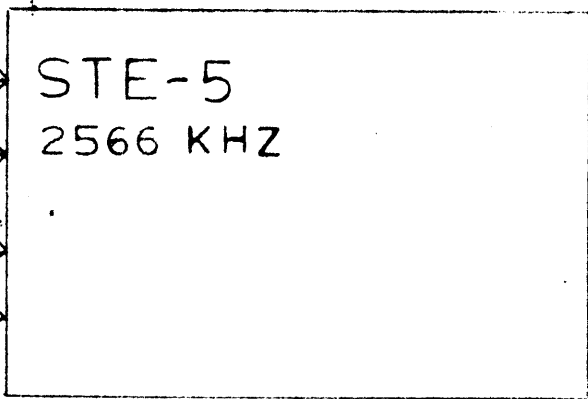

110V AC

REMOTE ON-OFF CONTROL

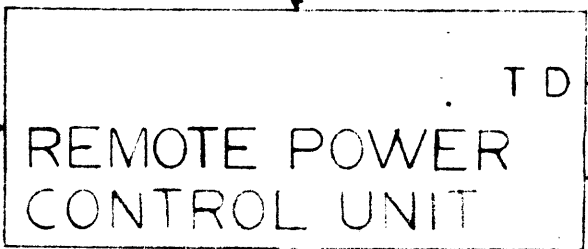

TD

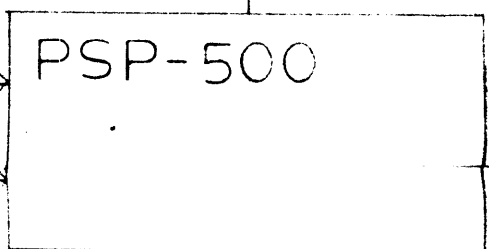

RF INDICATOR ←

AUDIO 600Ω
A3H PTT
A3J PTT
A3A PTT
FUTURE

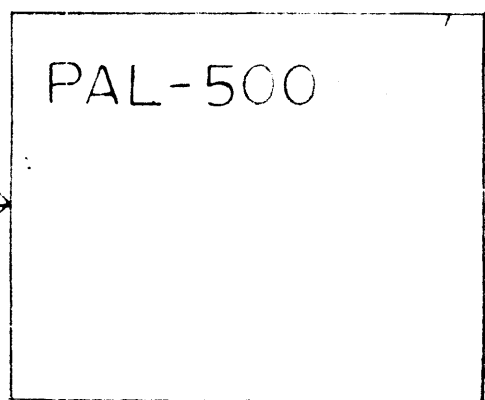
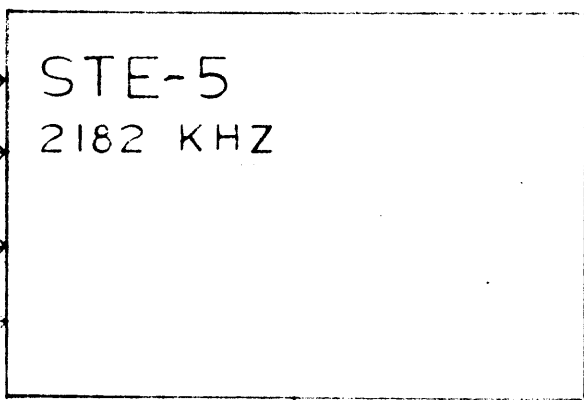

110V AC

REMOTE ON-OFF CONTROL

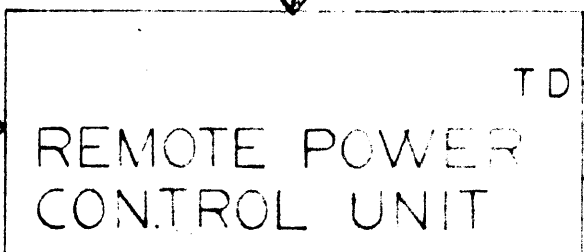

TD

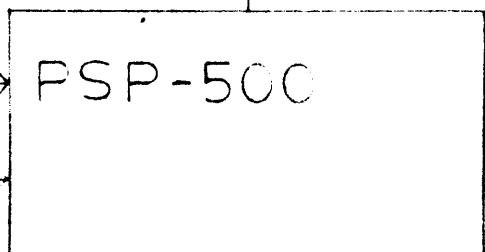

UNLESS OTHERWISE DIMENSIONS ARE IN INCHES AND INCLUDE CHEMICAL OR PLATED FINISH

TOLERANCES

DECIMALS
.X ± .05
.XX ± .01
.XXX ± .005

MATERIAL

FINISH

QTY / UNIT	MODEL USED ON	ASS'Y NO.
APPLICATION		
CODE		

NOTICE TO PERSONS RECEIVING THIS DRAWING
THE TECHNICAL MATERIEL CORPORATION claims proprietary right in the material disclosed hereon. This drawing is issued in confidence for engineering information only and may not be reproduced or used to manufacture anything shown hereon without permission from THE TECHNICAL MATERIEL CORPORATION to the user. This drawing is loaned for mutual assistance and is subject to recall at any time.

					REVISIONS		
E.M.N.NO	DRAFT	CHKD	ZONE	LTR	DESCRIPTION	DATE	APPROVED

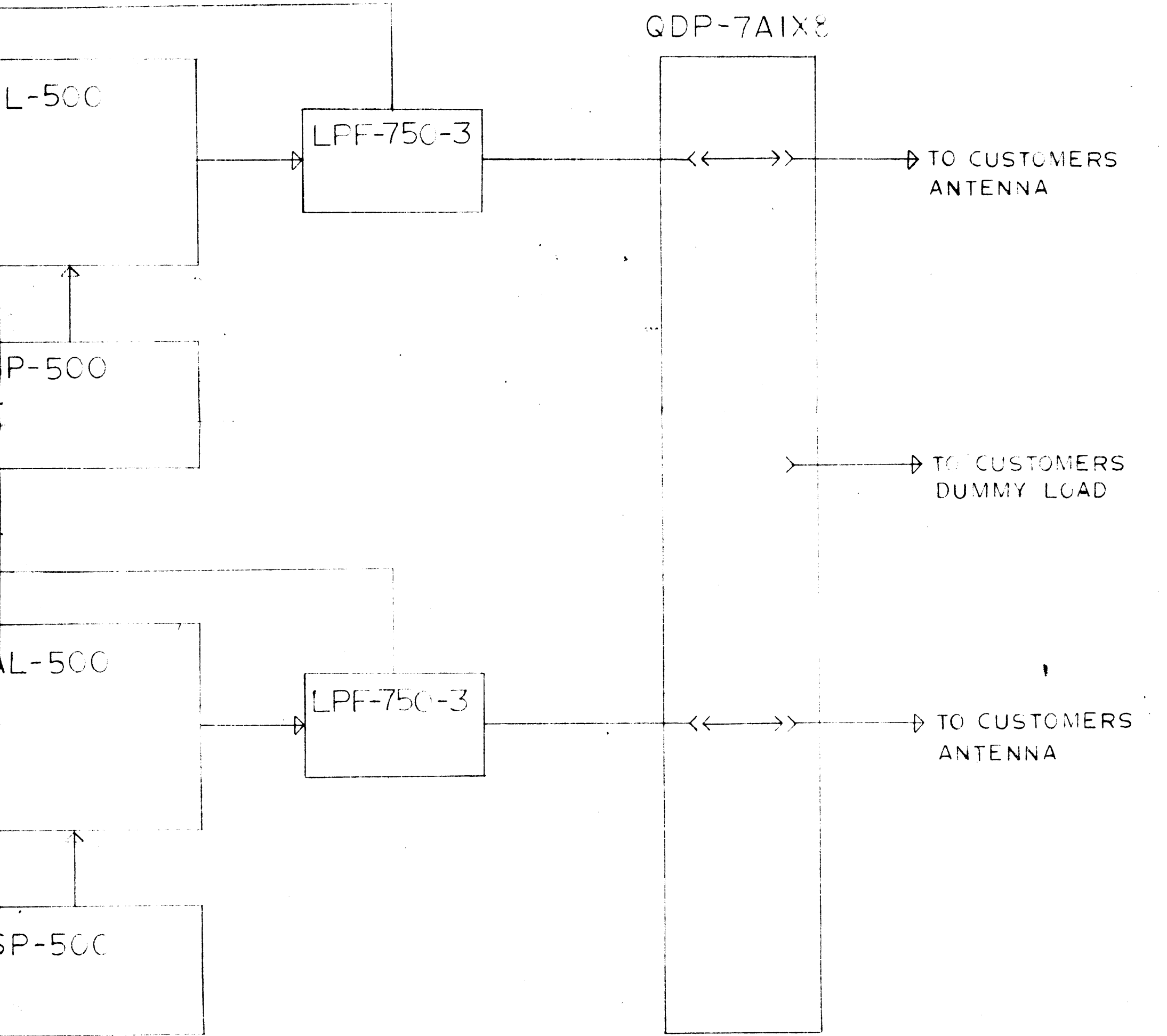

NOTE: CUSTOMER WILL SUPPLY -48V DC FOR ALL CONTROL CIRCUITS.

QTY. REQ.	ITEM	PART NO.	DESCRIPTION	SYMBOL
-----------	------	----------	-------------	--------

LIST OF MATERIAL

UNLESS OTHERWISE SPECIFIED DIMENSIONS ARE IN INCHES AND INCLUDE CHEMICALLY APPLIED OR PLATED FINISHES	FINAL APPROVAL	DATE
	MECH. DES.	DATE
	ELECT. DES.	DATE
	CHECKED	DATE
	DRAWN C. D. DEAN	DATE 7-9-71

THE TECHNICAL MATERIEL CORP.
MAMARONECK, NEW YORK

Figure 4-1
Flow Chart

MATERIAL	SIZE	CODE IDENT NO.	DWG NO.	ISSUE
FINISH	C	82679		
SCALE		SHEET		OF

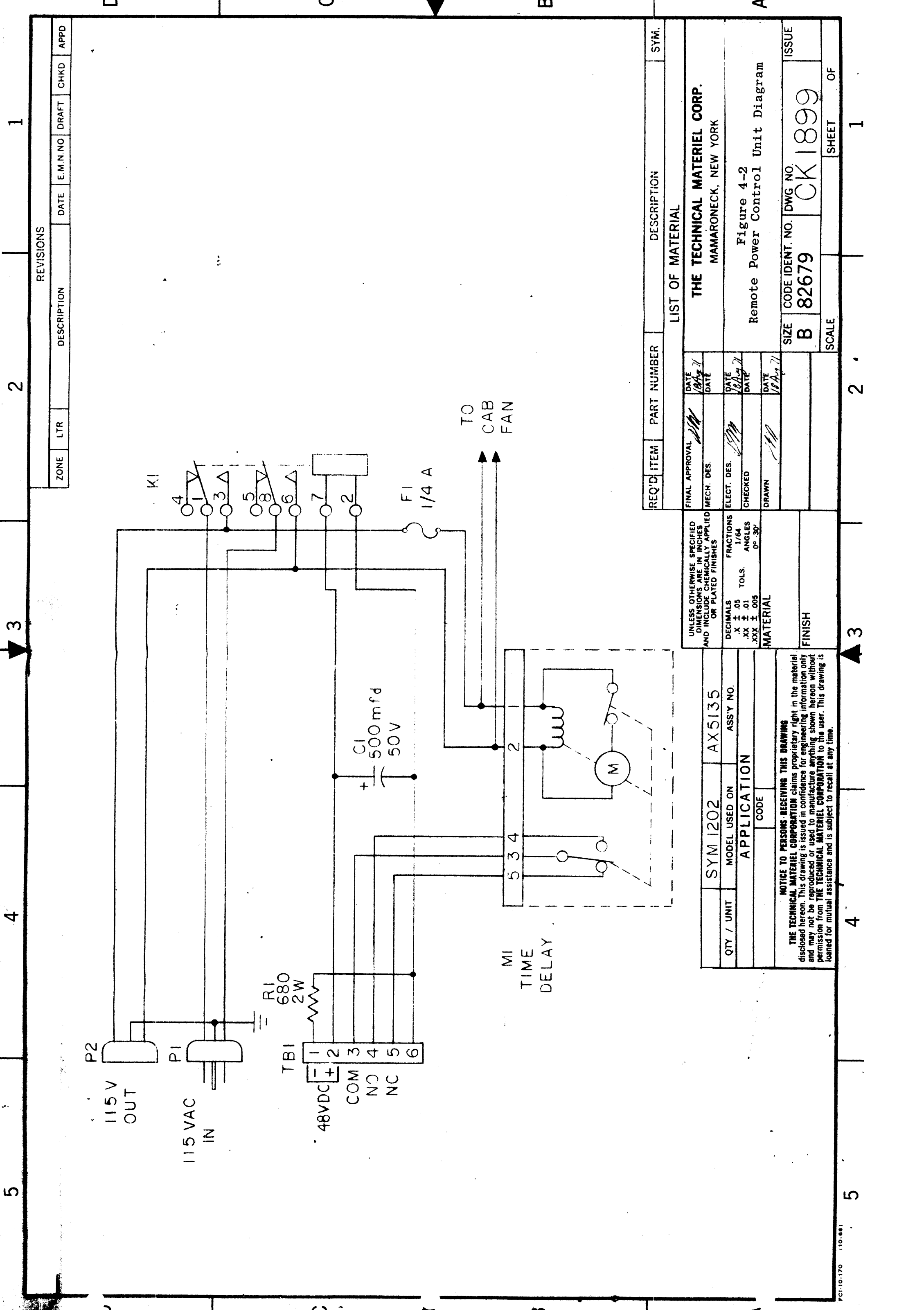

REVISIONS			
ZONE	LTR	DESCRIPTION	DATE

APPD	CHKD	DRAFT	E.M.N.NO	1
------	------	-------	----------	---

REQ'D ITEM	PART NUMBER	DESCRIPTION	SYMBOL
LIST OF MATERIAL			
THE TECHNICAL MATERIEL CORP.			
MAMARONECK, NEW YORK			
Figure 4-2			
Remote Power Control Unit Diagram			
SIZE	CODE IDENT. NO.	DWG NO.	ISSUE
B	82679	CK 1899	
SCALE	SHEET	OF	
			1

UNLESS OTHERWISE SPECIFIED DIMENSIONS ARE IN INCHES AND INCLUDE CHEMICALLY APPLIED OR PLATED FINISHES	DATE
DECIMALS	1/8, 1/4, 3/8, 1/2, 5/8, 3/4, 7/8
FRACTIONS	1/64
TOLS.	.XX ± .01
ANGLES	0°-30°
MATERIAL	
FINISH	

QTY / UNIT	MODEL USED ON	ASSY NO.
	AX5135	
APPLICATION		
CODE		

NOTICE TO PERSONS RECEIVING THIS DRAWING
 THE TECHNICAL MATERIEL CORPORATION claims proprietary right in the material disclosed hereon. This drawing is issued in confidence for engineering information only and may not be reproduced or used to manufacture anything shown hereon without permission from THE TECHNICAL MATERIEL CORPORATION to the user. This drawing is loaned for mutual assistance and is subject to recall at any time.

REVISIONS

ZONE	LTR	DESCRIPTION	DATE	E.M.N.NO	DRAFT	CHKD	APPD

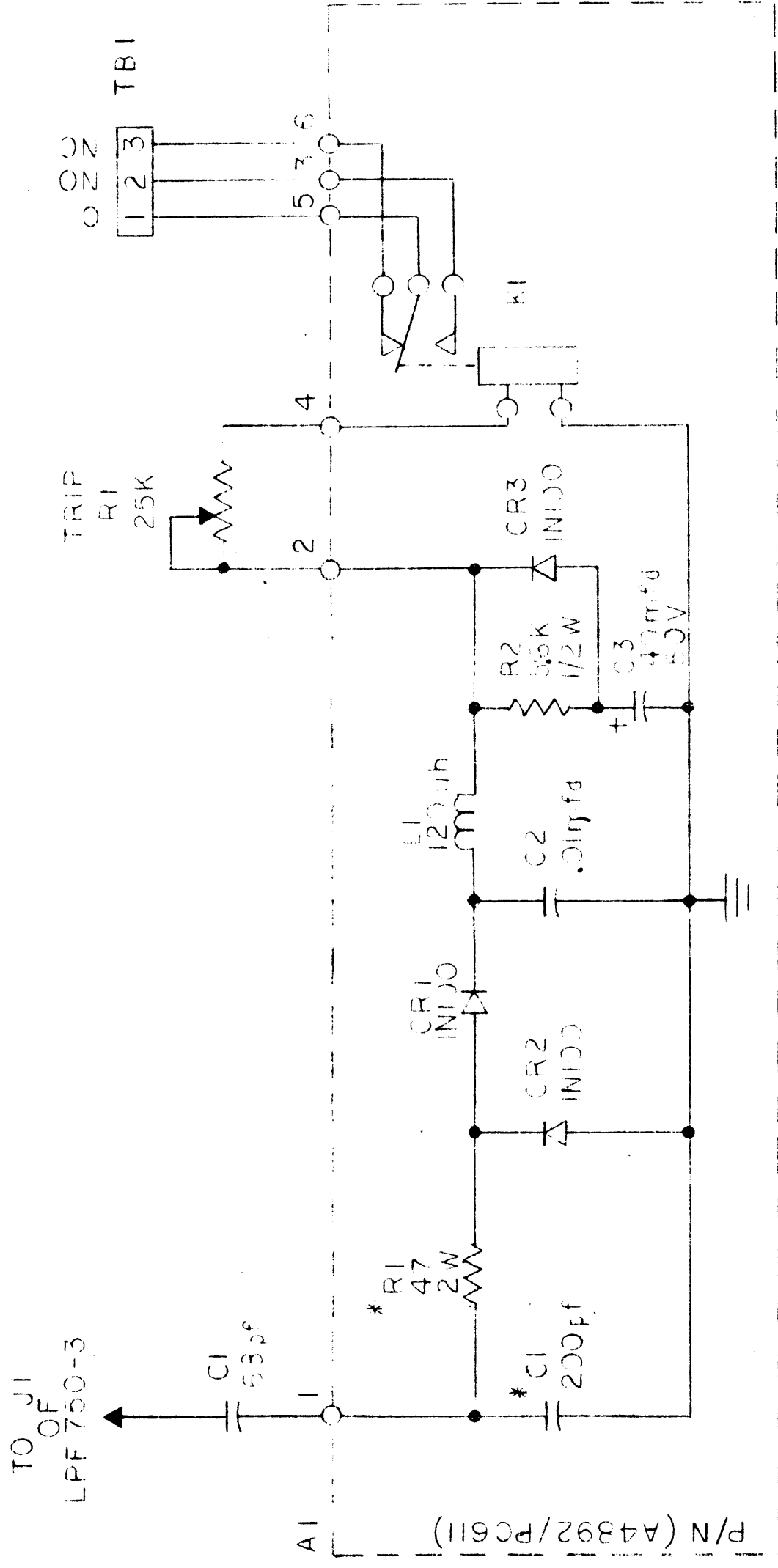

* PARTIAL REFERENCE DESIGNATIONS ARE SHOWN.
 PREFIX WITH SUB-ASSEMBLY DESIGNATION. (A/C)

REQ'D ITEM	PART NUMBER	DESCRIPTION	SYM.
LIST OF MATERIAL			
THE TECHNICAL MATERIEL CORP.			
MAMARONECK, NEW YORK			
Figure 4-3			
RF Output Indicator Diagram			
SIZE	CODE IDENT. NO.	DWG NO.	ISSUE
B	82679	CK1902	
SCALE	SHEET		OF

FINAL APPROVAL	DATE	MECH. DES	DATE	ELECT. DES.	DATE	CHECKED	DATE	DRAWN	DATE

UNLESS OTHERWISE SPECIFIED DIMENSIONS ARE IN INCHES AND INCLUDE CHEMICALLY APPLIED OR PLATED FINISHES		FRACTIONS		ANGLES	
DECIMALS	.X ± .05	TOLS.	1/64		
.XX ± .01			0° - 30'		
.XXX ± .005					
MATERIAL		FINISH			

QTY / UNIT	MODEL USED ON	ASSY NO.
APPLICATION		

NOTICE TO PERSONS RECEIVING THIS DRAWING
 THE TECHNICAL MATERIEL CORPORATION claims proprietary right in the material disclosed hereon. This drawing is issued in confidence for engineering information only and may not be reproduced or used to manufacture anything shown hereon without permission from THE TECHNICAL MATERIEL CORPORATION to the user. This drawing is loaned for mutual assistance and is subject to recall at any time.

SECTION 5

MAINTENANCE

5-1. INTRODUCTION

The SYM-1202 System is designed for long term, trouble-free operation. When it becomes necessary to perform alignment and/or adjustments to the system, it is recommended that technicians perform the necessary operations outlined in the associated PAL-500 and STE-5A technical manuals. The following data is provided for troubleshooting and maintenance.

- a. Overall Flow Chart Diagram (Section 4, figure 4-1).
- b. Component Location (figure 1-1).
- c. System Wiring Diagram (figure 2-5).

5-2. TEST EQUIPMENT REQUIRED

Table 5-1 lists the test equipment required for maintaining and troubleshooting the transmitter. Refer to the STE-5 and PAL-500 technical manuals for additional equipment required to maintain and troubleshoot these two components.

TABLE 5-1. TEST EQUIPMENT REQUIRED

EQUIPMENT	TYPE
Signal Generator:	Hewlett-Packard Model 606A, or equivalent
VTVM:	Hewlett-Packard Model 410B, or equivalent
Multimeter:	Simpson Model 260, or equivalent
Oscilloscope:	Tektronix, Model 541A or equivalent

5-3. OPERATOR MAINTENANCE

Operators maintenance consist of maintaining recordings of operating transmitter front panel meter readings on a routine basis. During off the air periods the operator should perform the following preventive maintenance procedures:

- (1) Check and record exciter operating frequency.
- (2) Check and replace or tighten if necessary, all spare fuses, control knobs, indicator lamps, interconnect cabling and external equipment connections.

- (3) Clean all air filters and remove dust and foreign matter accumulated during operating periods.
- (4) Check mechanical operation of operational controls (tuning control rotations, (clockwise and counterclockwise) ON/OFF switches and circuit breakers.
- (5) Check chassis and terminal strip hardware for looseness, and tighten as necessary.
- (6) Check and record the adjustable bias control ranges, and report any abnormalities to supervisor in charge. (Refer to PAL-500 technical manual).
- (7) Check Remote circuitry to insure operation. (Mode selection and AC ON/OFF)
- (8) Check PA, Bandswitch for signs of overheating.

5-5. TROUBLESHOOTING

NOTE

Before troubleshooting determine if transmitter is connected for remote or local operation.

Troubleshooting the SYM-1202 consists of isolating faults to either the STE-5A Exciter or the PAL-500 Power Amplifier. Once a fault is isolated to a particular unit refer to the associated technical manuals for detailed troubleshooting procedures of the STE-5A or the PAL-500. Refer to operator's section for normal indications.

To isolate a fault between the STE-5A exciter and PAL-500 amplifier proceed as follows:

- a. Exciter Check - Disconnect the STE-5A RF OUTPUT from the LOW jack on the RFE and connect the STE-5A to a 50 ohm, 1 watt, non-inductive dummy load. Use an oscilloscope to monitor the exciter output, referring to the STE-5A technical manual for normal indications and exciter control positions.
- b. External Signal Inputs Connections - Use an ohmmeter or VTVM to check for continuity and/or signal levels via interconnecting cables between the STE-5A and PAL-500. (Refer to figure 2-5).
- c. PAL-500 Check - Disconnect the STE-5A and connect a signal generator to the RFE LOW input jack. Signalgenerator output and frequency must be within the range normally provided by the STE-5A exciter. Operate the PAL-500 into a dummy load (if available) and monitor the PAL-500 meters for proper operation. (Refer to the PAL-500 technical manual for normal indications. Refer to paragraph 2-3 and check all internal and external jack connections.)
- d. Remote AC ON/OFF check - Check faulty Remote Power Control Unit as follows:

WARNING

Primary AC voltage is present on relay K1 contacts. Use caution when taking voltage measurements.

1. Check for open fuse F1 (1/4 amp).
2. Remove AC input plug P1 from cabinet AC strip and temporarily disconnect leads on TB1 terminals 3 and 4.
3. Refer to figure 4-2 and apply 48 vdc between terminals 1 and 2 on TB1 (located on Line Control Unit).
4. Observe that control relay K1 energizes (K1 is a 24 vdc relay) and contact sets 1 and 3, 6 and 8 close. (Closed contacts should provide continuity from plug P1 to plug P2.)
5. Connect plug P1 to AC strip. (Connecting P1 to AC strip applies 115 vac to relay K1 contacts.)
6. Check plug P2 for 115 vac when 48 vdc is applied to terminals 1 and 2 on TB-1.
7. Observe that time delay M1 is operating and after approximately 60 seconds check for a short between terminals 3 and 4 on TB1.
8. This completes the remote power control unit check, repair or replace as necessary any defective component.
9. Reconnect all cables and leads temporarily disconnected in trouble-shooting procedure.

SECTION 6

PARTS LIST

6-1. INTRODUCTION

Reference designations have been assigned to identify all Subassembly/PC Card parts of the equipment. They are used for marking the equipment and are included on drawings, diagrams, and in the parts list. The letters of a reference designation indicate the kind of part (generic group), such as resistor, capacitor, unit, subassembly, PC card, transistor, integrated circuit, etc. The number differentiates between parts of the same generic group. Sockets associated with a particular plug-in device, such as electron tubes or lamps, are identified with a reference designation which includes the reference designation of the plug-in device.

NOTE

Parts list data for the SYM-1202 is divided between the STE-5A, PAL-500 and LPF-750-3 technical manuals. Refer to the applicable technical manual for Technical Materiel Corporation part numbers when ordering replacement parts for the above mentioned modular units.

Parts list for Remote Power Control Unit AX5135 and Output Indicator AX5137 are listed on the following page.

REMOTE POWER CONTROL UNIT AX-5135

REF SYMBOL	DESCRIPTION	TMC PART NUMBER
C1	Capacitor, fixed, electrolytic: 500 mfd, 50 v	CE116-10VN
F1	Fuse, slow blow	FU102-.025
K1	Relay, armature, DPDT	RL168-2C10-24 vdc
M1	Timer	TI105-3
P1	Connector Plug, male, AC	PL218
P2	Connector Plug, female, AC	PL176
R1	Resistor, fixed, composition: 680 ohm 2 watt ±5%	RC42GF681J
TB1	Terminal Board, Barrier	TM102-6
XF1	Fuse Holder	FH100-1
XK1	Socket, relay	TS101-P01
<u>RF OUTPUT INDICATOR AX5137</u>		
A1	P/C Board Assembly	A4892*
C1	Capacitor, fixed, mica	CM15B680K
R1	Resistor, variable, composition	RV106UX10B253A
TB1	Terminal Board, Barrier	TM100-3
<p>* The parts list for Assembly, A4892 is listed separately.</p>		

ASSEMBLY A4892 (p/o AX5137)

REF SYMBOL	DESCRIPTION	TMC PART NUMBER
C1	Capacitor, fixed, mica: 200 pf	CM15B201K
C2	Capacitor, fixed, ceramic: .01 mfd	CC100-16
C3	Capacitor, fixed, electrolytic: 40 mfd, 50 v	CE105-40-50
CR1	Semiconductor device, diode	1N100
CR2	Same as CR1	
CR3	Same as CR1	
K1	Relay, armature, SPDT	RL142
L1	Coil, RF	CL240-120
R1	Resistor, fixed, composition: 47 ohm, 2 watt ±5%	RC42GF470J
R2	Resistor, fixed, composition: 5,600 ohm 1/2 watt ±5%	RC20GF562J