

NOTICE

THE CONTENTS AND INFORMATION CONTAINED IN THIS INSTRUCTION MANUAL IS PROPRIETARY TO THE TECHNICAL MATERIEL CORPORATION TO BE USED AS A GUIDE TO THE OPERATION AND MAINTENANCE OF THE EQUIPMENT FOR WHICH THE MANUAL IS ISSUED AND MAY NOT BE DUPLICATED EITHER IN WHOLE OR IN PART BY ANY MEANS WHATSOEVER WITHOUT THE WRITTEN CONSENT OF THE TECHNICAL MATERIEL CORPORATION.

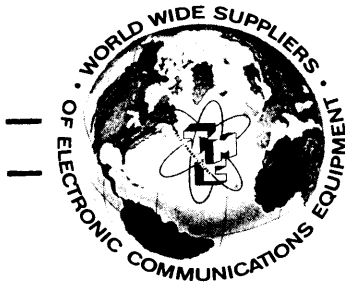

THE TECHNICAL MATERIEL CORPORATION

C O M M U N I C A T I O N S E N G I N E E R S

700 FENIMORE ROAD

MAMARONECK, N. Y.

W a r r a n t y

The Technical Materiel Corporation, hereinafter referred to as TMC, warrants the equipment (except electron tubes,*fuses, lamps, batteries and articles made of glass or other fragile or other expendable materials) purchased hereunder to be free from defect in materials and workmanship under normal use and service, when used for the purposes for which the same is designed, for a period of one year from the date of delivery F.O.B. factory. TMC further warrants that the equipment will perform in a manner equal to or better than published technical specifications as amended by any additions or corrections thereto accompanying the formal equipment offer.

TMC will replace or repair any such defective items, F.O.B. factory, which may fail within the stated warranty period, PROVIDED:

1. That any claim of defect under this warranty is made within sixty (60) days after discovery thereof and that inspection by TMC, if required, indicates the validity of such claim to TMC's satisfaction.
2. That the defect is not the result of damage incurred in shipment from or to the factory.
3. That the equipment has not been altered in any way either as to design or use whether by replacement parts not supplied or approved by TMC, or otherwise.
4. That any equipment or accessories furnished but not manufactured by TMC, or not of TMC design shall be subject only to such adjustments as TMC may obtain from the supplier thereof.

Electron tubes*furnished by TMC, but manufactured by others, bear only the warranty given by such other manufacturers. Electron tube warranty claims should be made directly to the manufacturer of such tubes.

TMC's obligation under this warranty is limited to the repair or replacement of defective parts with the exceptions noted above.

At TMC's option any defective part or equipment which fails within the warranty period shall be returned to TMC's factory for inspection, properly packed with shipping charges prepaid. No parts or equipment shall be returned to TMC, unless a return authorization is issued by TMC.

No warranties, express or implied, other than those specifically set forth herein shall be applicable to any equipment manufactured or furnished by TMC and the foregoing warranty shall constitute the Buyers sole right and remedy. In no event does TMC assume any liability for consequential damages, or for loss, damage or expense directly or indirectly arising from the use of TMC Products, or any inability to use them either separately or in combination with other equipment or materials or from any other cause.

*Electron tubes also include semi-conductor devices.

PROCEDURE FOR RETURN OF MATERIAL OR EQUIPMENT

Should it be necessary to return equipment or material for repair or replacement, whether within warranty or otherwise, a return authorization must be obtained from TMC prior to shipment. The request for return authorization should include the following information:

1. Model Number of Equipment.
2. Serial Number of Equipment.
3. TMC Part Number.
4. Nature of defect or cause of failure.
5. The contract or purchase order under which equipment was delivered.

PROCEDURE FOR ORDERING REPLACEMENT PARTS

When ordering replacement parts, the following information must be included in the order as applicable:

1. Quantity Required.
2. TMC Part Number.
3. Equipment in which used by TMC or Military Model Number.
4. Brief Description of the Item.
5. The *Crystal Frequency* if the order includes crystals.

PROCEDURE IN THE EVENT OF DAMAGE INCURRED IN SHIPMENT

TMC's Warranty specifically excludes damage incurred in shipment to or from the factory. In the event equipment is received in damaged condition, the carrier should be notified immediately. Claims for such damage should be filed with the carrier involved and not with TMC.

All correspondence pertaining to Warranty Claims, return, repair, or replacement and all material or equipment returned for repair or replacement, within Warranty or otherwise, should be addressed as follows:

THE TECHNICAL MATERIEL CORPORATION
Engineering Services Department
700 Fenimore Road
Mamaroneck, New York

ADDENDUM #1

The purpose of this addendum is to adapt the Technical Manual for Sideband Generator SBG-1 or SBG-2 to cover Frequency Standard System Model CPO-1A.

This manual with the supplied interconnecting diagram but less the individual manual for the Sideband Exciter Model CBE-1, 2 and Tone Intelligence Unit Model TIS-3 provides coverage for Frequency Standard System Model CPO-1A.

When using this manual disregard all references to the Model CBE-1, 2 and TIS-3.

ADDENDUM #2

for

SIDEBAND GENERATOR SBG-1 OR SBG-2

The Tone Intelligence Unit TMC Model TIS-3, referenced in this manual does not form a part of the frequency determining and rf translation units contained within the SBG-1, however, since the TIS-3 is utilized in conjunction with the SBG in most of our transmitter installations, it is referenced throughout the system description for the SBG.

The function of the TIS-3 is to provide audio tones for A-1, F-1 and F-4 type of transmission to the CBE in lieu of audio intelligence signals. Should your system not contain the TIS-3, kindly disregard any information to the TIS-3 within the description.

CHANGE NO. 4 SBG-1 and SBG-2



INSTRUCTION BOOK CHANGE NOTICE

Date 3/4/64

Manual affected: Sideband Generator SBG-1 or SBG-2 IN -220

All references to Primary Standard Model CSS-1 apply to Model CSS-1B

Figure I-3-1 Page 3-7/3-8 and Figure I-3-2 Page 3-9/3-10

Change designation of Primary Standard from "CSS-1" to "CSS-1B".

On CSS-1B unit change fuse values as follows:

FROM	TO
.5A/115V	1A/115V
.25A/230V	.5A/230V
B+.75A	B+1A

SHOULD ADDITIONAL COPIES OF THIS CHANGE NOTICE BE REQUIRED, PLEASE CONTACT:

THE TECHNICAL MATERIEL CORP., 700 Fenimore Road, Mamaroneck, New York

Attn.: Director of Eng. Services.

FOREWORD

TMC manufactures single sideband transmitters whose output ranges from 350 to 40,000 watts (PEP). In any given type, the exciter units vary from model to model in order to meet varying field requirements. To satisfy this condition most practically, individual manuals on each exciter unit are written; then combined as required to cover any over-all exciter. In this way the "building block" manuals may be assembled in many arrangements in order to fully describe a great many specific exciter equipments.

The following colloquial terms are used in this preliminary manual to simplify formal nomenclature terminology:

FORMAL	COLLOQUIAL
Sideband Generator SBG-1* (Modulator-Oscillator Group AN/URA-30).	SBG*
Sideband Exciter CBE-1* (Oscillator, Radio Frequency O-714/UR).	CBE*

FORMAL	COLLOQUIAL
Controlled Precision Oscillator CPO-1 (Oscillator-Power Supply Group AN/URA-31).	CPO
Tone Intelligence Unit TIS-3 (Telegraph Terminal, TH-39A/UGT).	TIS

*TMC manufactures two types of sideband generators:

a. Wide band (SBG-1) using sideband exciter (CBE-1) whose audio bandwidths extend from 350 to 7500 cycles.

b. Narrow band (SBG-2) using sideband exciter (CBE-2) whose audio bandwidths extend from 350 to 3300 cycles.

Unless otherwise stated, this manual deals with the SBG-1 and CBE-1 units.

TABLE OF CONTENTS OF SIDEBAND GENERATOR MODELS SBG-1 AND SBG-2

Part	Title	Part	Title
I	GENERAL DESCRIPTION OF SIDEBAND GENERATOR MODEL SBG-1 (AN/URA-30) OR SBG-2 (NO AN DESIGNATION)	III(C)	PRIMARY STANDARD, CSS-1
II	TECHNICAL MANUAL FOR SIDEBAND EXCITER MODEL CBE-1 (O-714/UR) OR CBE-2 (NO AN DESIGNATION)	III(D)	DIVIDER CHAIN, CHL-1
III	TECHNICAL MANUALS FOR CONTROLLED PRECISION OSCILLATOR MODEL CPO-1 (AN/URA-31)	III(E)	CONTROL OSCILLATOR, CLL-1 (LOW FREQUENCY LOOP)
III(A)	FREQUENCY AMPLIFIER, CHG-1 OR -2 AND POWER SUPPLY, CPP-1 OR -5 (HIGH FREQUENCY LOOP)	III(F)	POWER SUPPLY, CPP-2
III(B)	CONTROLLED MASTER OSCILLATOR, CMO-1	III(G)	APPENDIX - FACTORY CHECKOUT TEST PROCEDURE
		IV	TECHNICAL MANUAL FOR TONE INTELLIGENCE UNIT MODEL TIS-3 (TH-39A/UGT)
		V	APPENDIX - EXCITER FRAME AND ACCESSORIES

TABLE OF CONTENTS OF PART I
(GENERAL DESCRIPTION OF SIDEBAND GENERATOR
SBG-1, -2)

SECTION 1—GENERAL DESCRIPTION		SECTION 4—PRINCIPLES OF OPERATION (C nt.)	
Paragraph	Page	Paragraph	Page
I-1-1.	Introduction 1-1	I-4-5.	Controlled Master Oscillator, Model CMO-1 4-8
I-1-2.	Functional Description of GPT-10K, GPT-40, and SBT-1K Sideband Generator Equipment 1-1	I-4-6.	Controlled Oscillator, Model CLL-1 Low Frequency Loop 4-12
I-1-3.	Reference Data 1-1	I-4-7.	Primary Standard Model CSS-1 4-12
SECTION 2—INSTALLATION		I-4-8.	Divider Chain Model CHL-1 4-14
I-2-1.	General 2-0	I-4-9.	Power Supply, Model CPP-2 4-14
I-2-2.	Production Line Checkout 2-0	I-4-10.	Tone Intelligence Unit Model TIS-3 4-14
I-2-3.	Locations of Synthesized Exciter 2-0	SECTION 5—TROUBLE-SHOOTING	
I-2-4.	Assembly of Synthesized Exciter 2-0	I-5-1.	General 5-1
I-2-5.	Installation Checkout 2-0	I-5-2.	Trouble-Shooting Techniques 5-1
SECTION 3—OPERATOR'S SECTION		a.	General Considerations 5-1
I-3-1.	General 3-1	b.	Trouble-Shooting Charts Based on Operating Procedures 5-1
I-3-2.	Tuning and Loading Procedure for Exciter 3-1	c.	Tables of Voltage and Resistance; Waveform Data 5-1
SECTION 4—PRINCIPLES OF OPERATION		d.	Trouble-Shooting Procedures Based on Circuit Sectionalization 5-2
I-4-1.	General 4-1	SECTION 6—MAINTENANCE	
a.	Automatic Phase Control System 4-1	I-6-1.	General 6-1
b.	Phase Detector Circuit 4-2	I-6-2.	Operator's Maintenance 6-1
c.	Frequency Translations in High Frequency and Low Frequency Loops 4-2	I-6-3.	Preventive Maintenance 6-1
d.	Frequency Division by Phantastrons 4-4	a.	Once Each Shift During an "On the Air" Period 6-1
I-4-2.	Sideband Exciter, Model CBE-1 4-4	b.	Daily During an "Off the Air" Period 6-1
I-4-3.	Power Supply, Model CPP-1 4-6	c.	Monthly During "Off the Air" Periods 6-1
I-4-4.	Frequency Amplifier, Models CHG-1 or -2 (High Frequency Loop). 4-6	I-6-4.	Corrective Maintenance 6-2

LIST OF ILLUSTRATIONS

SECTION 1—GENERAL DESCRIPTION		SECTION 4—PRINCIPLES OF OPERATION	
Figure	Page	Figure	Page
I-1-1-a.	Front View of Sideband Generator in Relation to GPT-10K Transmitter	I-4-1.	Block Diagram of an Automatic Phase Control System
	v	I-4-2.	Simplified Schematic Diagram Illustrating Operation of Phase Detector Circuit Used in Controlled Precision Oscillator
I-1-1-b.	Front View of Sideband Generator in Relation to SBT-1K Transmitter		4-2
	vi	I-4-3.	Block Diagram Illustrating Frequency Translation in High Frequency and Low Frequency Loops
I-1-1-c.	Front View of Sideband Generator in Relation to GPT-40K Transmitter		4-3
	vii	I-4-4.	Sideband Exciter, CBE-1
SECTION 2—INSTALLATION		I-4-5.	Power Supply, CPP-1
I-2-1.	Wiring Diagram Showing Interconnection of SBG Rack Mounted Units for GPT-10K and GPT-40K Transmitters	I-4-6.	Amplifier, CHG-1 or - 2 (Component of SBG-1)
	2-1/2-2	I-4-7.	Block Diagram, High Frequency Loop, CHG
I-2-2.	Wiring Diagram Showing Interconnection of SBG Rack Mounted Units for SBT-1K Transmitters	I-4-8.	Master Oscillator, CMO-1 (Component of SBG-1).
	2-3/2-4	I-4-9.	Controlled Oscillator Model CLL-1 (Low Frequency Loop)
SECTION 3—OPERATOR'S SECTION		I-4-10.	Primary Standard Model CSS-1
I-3-1.	Location of Controls on Sideband Generator p/o GPT-10K (R) or GPT-40K (E)	I-4-11.	Divider Chain Model CHL-1
	3-7/3-8	I-4-12.	Synthesizer Power Supply Model CPP-2
I-3-2.	Location of Controls on Sideband Generator p/o SBT-1K (E, F, G, H)	I-4-13.	Functional Block Diagram of Tone Intelligence System Model TIS-3 (A Component of SBG-1)
	3-9/3-10		4-16

LIST OF TABLES

SECTION 3—OPERATOR'S SECTION

Table	Page
I-3-1.	Tuning/Loading Procedure for Exciter
	3-2
I-3-2.	Table of Equivalent Control Designations
	3-4
I-3-3.	Table of Relationships Between CMO Setting, Frequency Difference Between CMO and RF Output (Position MCS), and RF OUTPUT Frequency
	3-6

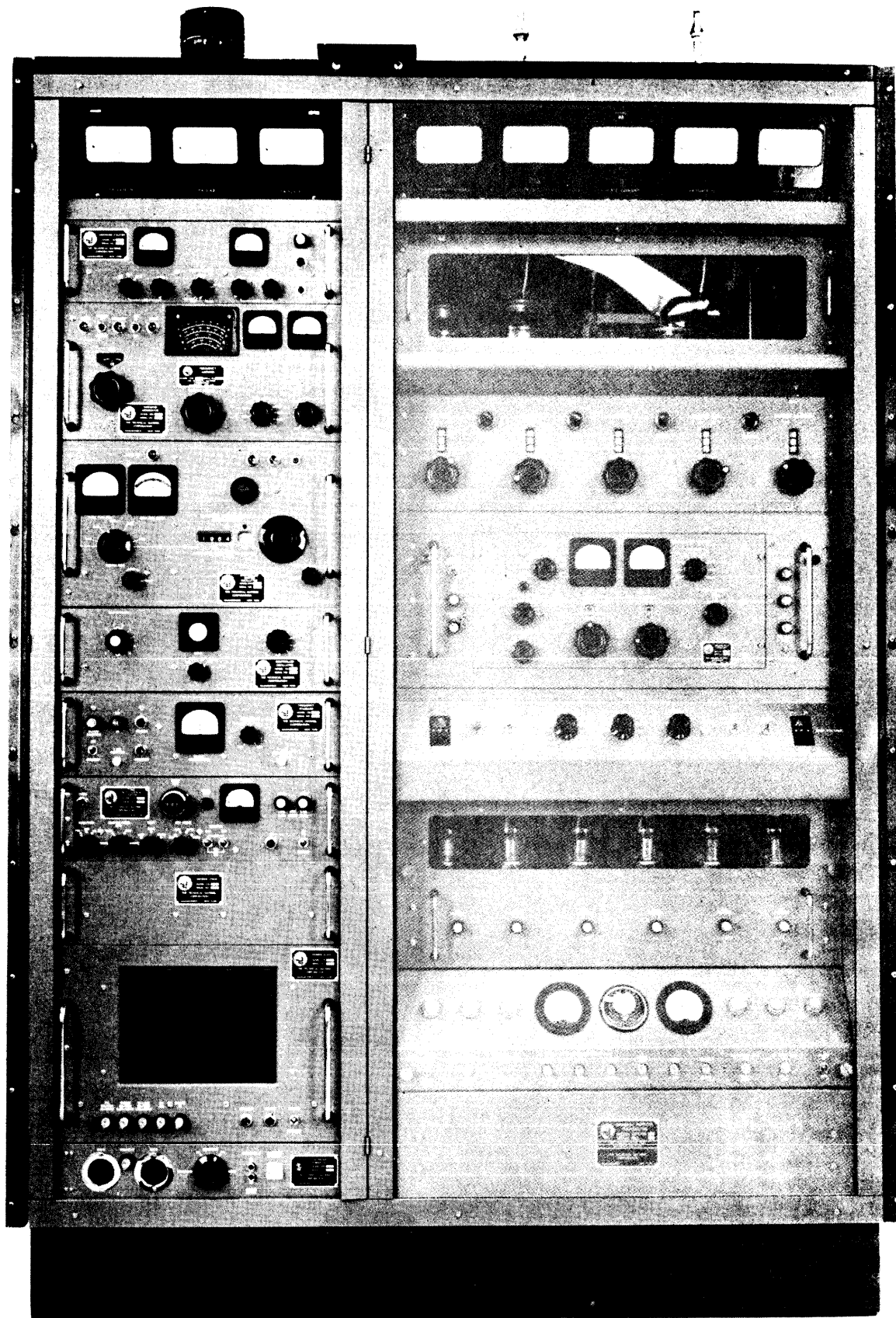

Figure I-1-1-a. Front View of Sideband Generator in Relation to GPT-10K Transmitter

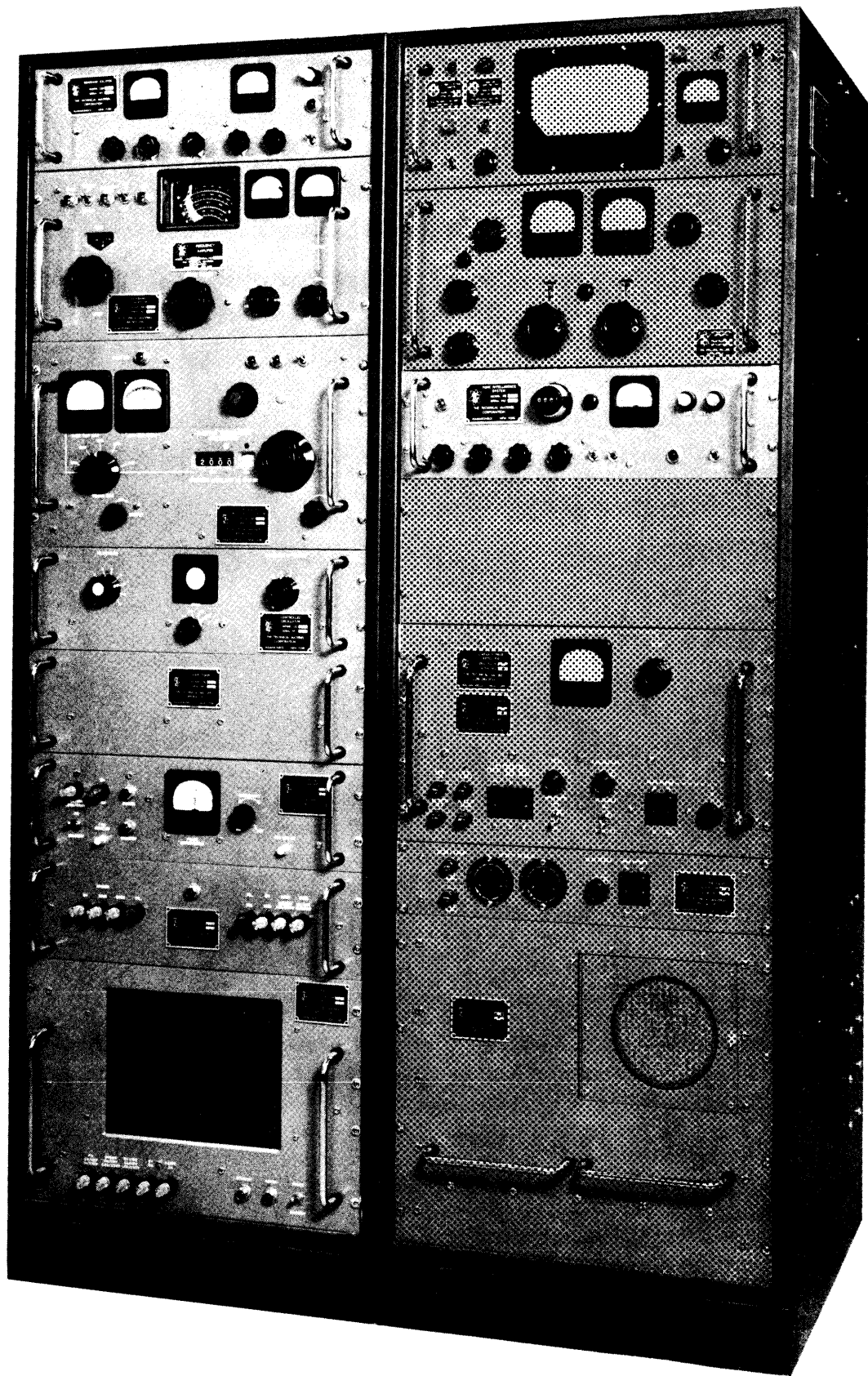

Figure I-1-1-b. Front View of Sideband Generator in Relation to SBT-1K Transmitter

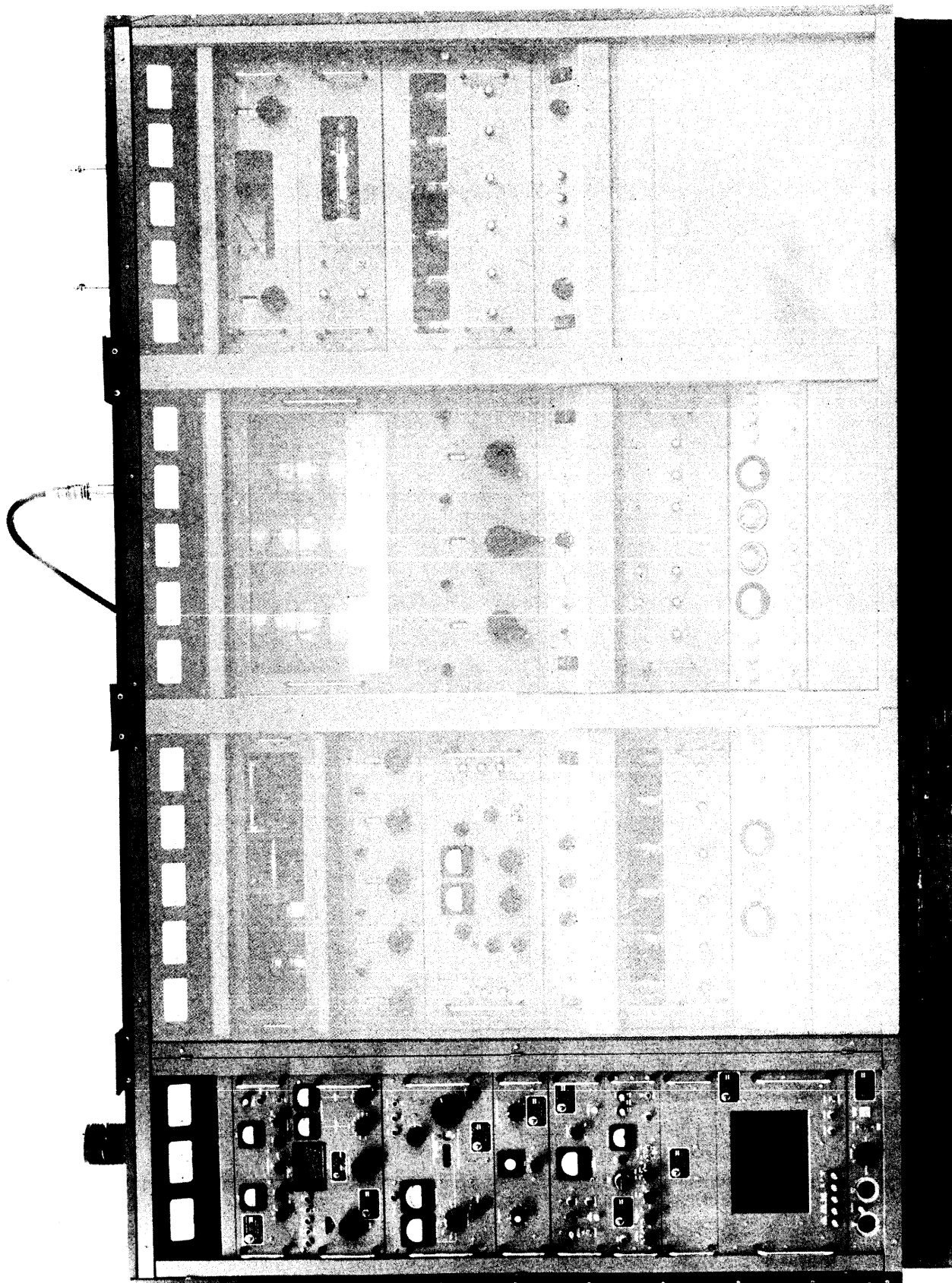

Figure I-1-1-c. Front View of Sideband Generator in Relation to GPT-40K Transmitter

SECTION I GENERAL DESCRIPTION

I-1-1. INTRODUCTION.

The Sideband Generator Models SBG-1 or SBG-2, sometimes called the synthesized exciter, consists of the following two equipments:

- a. Sideband Exciter Models CBE-1 or CBE-2.
- b. Controlled Precision Oscillator, Model CPO-1.

At the present time, Technical Materiel Corporation's Sideband Generator has three principle uses: Along with Tone Intelligence Unit Model TIS-3, it constitutes the exciter equipment for TMC's Transmitting Set, Radio, GPT-10K (R), GPT-40K (E), and SBT-1K (E, F, G, and H). Figure I-1-1-a shows the arrangement used with the GPT-10K (R); figure I-1-1-b, with the SBT-1K (E); figure I-1-1-c, with the GPT-40K (E).

I-1-2. FUNCTIONAL DESCRIPTION OF GPT-10K, GPT-40K, AND SBT-1K SIDEBAND GENERATOR EQUIPMENT.

Figure I-1-1-a is used for the brief functional description of the SBG.

The first removable drawer contains the CBE. This equipment accepts two channels of intelligence (each having a bandwidth of 7.5 kc) and frequency translates the audio inputs into lower and upper sidebands of 250 kc.

The second removable drawer contains the frequency amplifier, CHG-1, -2. This equipment receives the CBE's and CMO's outputs and numerous precise frequencies internally generated in order to translate CBE's, in combination with CMO's, output into the 1.75- to 33.75-mc range, precisely synthesized at any desired 100-cycle step.

The third removable drawer contains the controlled master oscillator, CMO-1. This equip-

ment supplies the CHGs with controlled frequencies in the 2- to 4-mc range, precisely synthesized at any desired 100-cycle step.

The fourth removable drawer contains controlled oscillator, CLL-1. Its purpose is to supply controlled frequencies in the 510- to 519.9-kc range, precisely synthesized by CPO's frequency standards at any desired 100-cycle step. CLL's synthesized output, then, is used to synthesize CMO's output in the 2- to 4-mc range, again at any desired 100-cycle step. Finally CMO's synthesized output is frequency translated in CHGs in order that CPO's output is any precise frequency in the range 1.750 to 33.750 megacycles in 100-cycle steps.

The fifth removable drawer contains the frequency standard, CSS-1. This equipment provides the synthesized exciter with a precise 1-mc frequency standard for frequency dividing and multiplying purposes.

The sixth removable drawer contains the tone intelligence unit, TIS-3. This equipment translates d-c pulses (FSK, FAX, CW) to audio pulses for presentation to CBE's input channels.

The seventh drawer contains the divider chain, CHL-1. This equipment provides the synthesized exciter with 100 cps, 1000 cps, and 100-kc and 500-kc frequencies, accurately divided down from the 1-mc standard.

The eighth removable drawer contains the main power supply, CPP-2.

Mounted on the rear of the frame is the CHG's power supply, CPP-1.

I-1-3. REFERENCE DATA.

For reference data on the synthesized exciter, see Parts II and III.

For reference data on the TIS-3, see Part IV.

SECTION 2 INSTALLATION

I-2-1. GENERAL.

a. The nine removable drawers of the Sideband Generator SBG plus TIS are shipped in four wooden cases as follows:

Case	Unit	Gross Weight
#2	CPP-1 CHL CSS	165 lbs
#3	CLL TIS CBE	194
#4	CNTO CHG	204
#5	CPP-2	125

Note: Case #1 contains rack in which units are mounted.

For further detail, see Shipping Data under Reference Data in various sections 1 of Part III. On arrival, uncrate each and carefully inspect for damage. If any damage is found, notify the carrier or supply department immediately. Inspect all packing for parts shipped as loose items.

b. The contents of all cases are packed according to military specifications. The units are wrapped to avoid being scratched, placed in cartons, cushioned against shock, and wrapped and sealed with waterproof material within which the units are kept dry with a desiccant.

c. Figures I-2-1 and I-2-2 show wiring details for the interconnections of the SBG rack-mounted units.

I-2-2. PRODUCTION LINE CHECKOUT.

Before any synthesized exciter is shipped, it has been assembled on the test floor and thor-

oughly checked against the manufacturer's test specifications. This procedure eliminates assembly line errors and guarantees that a synthesized exciter shall fully satisfy all design requirements. After this thorough checkout, the synthesized exciter is disassembled and packed for customer use. The packaging operations, in turn, are such as to minimize troubles that may develop in transit.

I-2-3. LOCATIONS OF SYNTHESIZED EXCITER.

The synthesized exciter is a major assembly of the SBT-1K (E, F, G, H), GPT-10K (R), and GPT-40K (E) transmitters. Locations of the synthesized exciter, therefore, are governed by the locations of associated transmitter equipment; installation details of the associated transmitter equipment, likewise, govern those of the synthesized exciter. Installation details of the transmitter equipment are given in pertinent technical manuals on the transmitters.

I-2-4. ASSEMBLY OF SYNTHESIZED EXCITER.

After the synthesized exciter is unpacked and located as discussed in paragraphs I-2-1, I-2-2, and I-2-3 above, the modular units are inserted into the exciter frame and 115/230 volt, 50/60 cycle power is connected to the synthesized exciter as indicated in figures I-2-1 and I-2-2. However, before turning power on the synthesized exciter, continuity checks should be made between terminals in line with information on figures I-2-1 and I-2-2. Inspection should be made for loose or broken connections.

I-2-5. INSTALLATION OF CHECKOUT.

See Part III; Manual III (G), Appendix; Part III (G)-1 of Factory Checkout Test Procedure on General Testing of the SBG System.

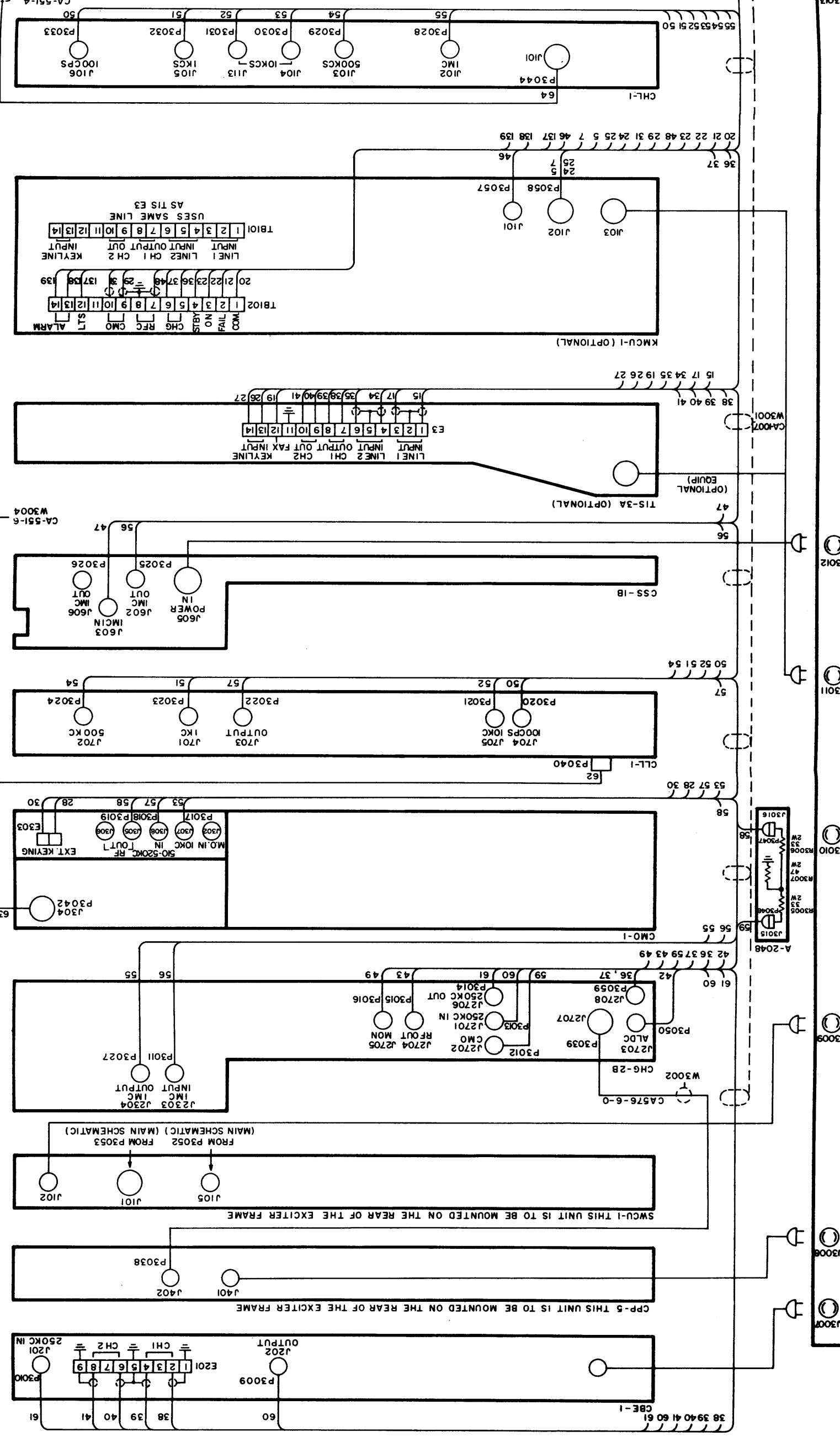

CK-925A
30965220

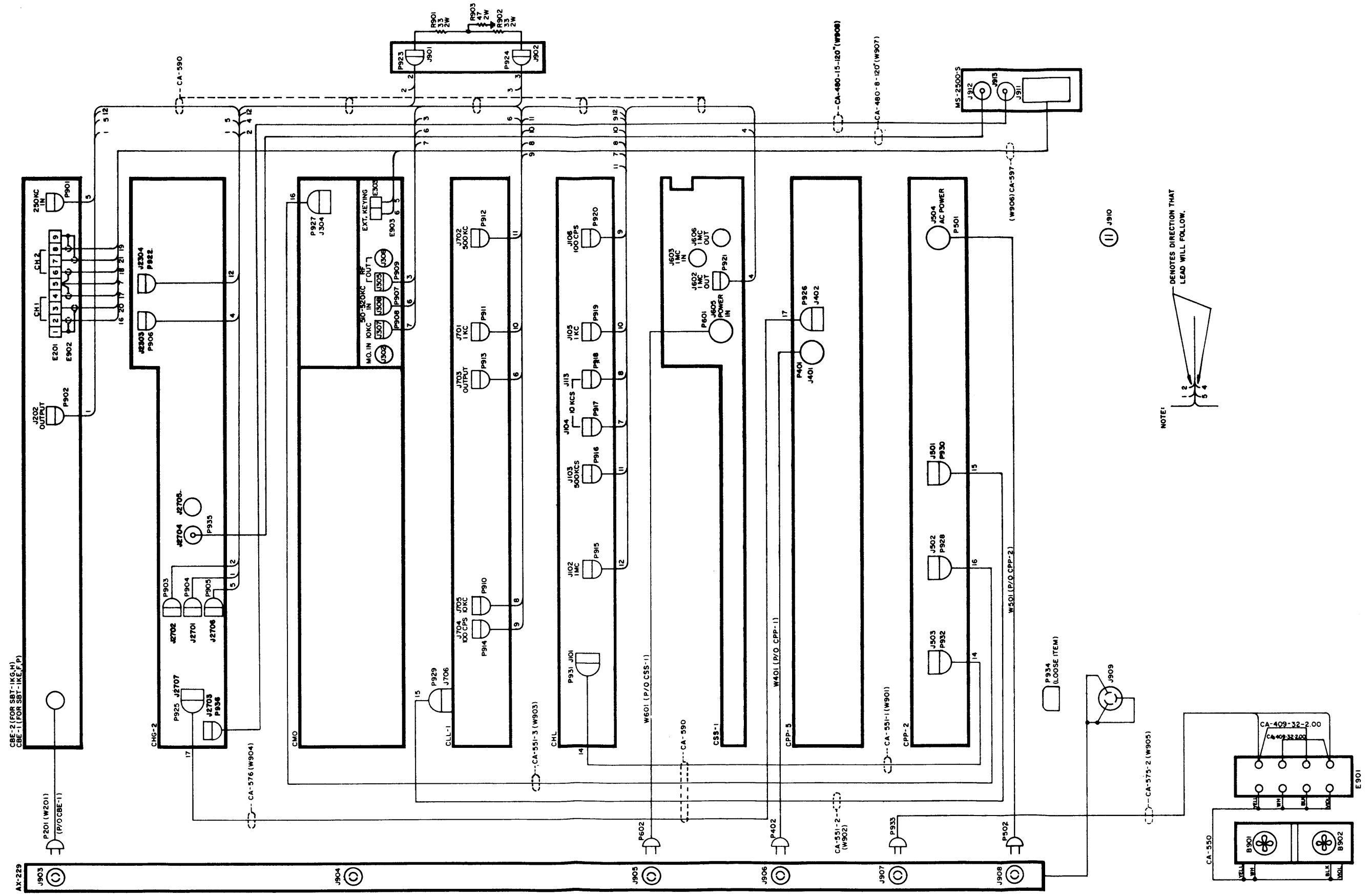

Figure I-2-2. Wiring Diagram Showing Interconnection of SBG Rack Mounted Units for SBT-1K Transmitters

SECTION 3 OPERATOR'S SECTION

I-3-1. GENERAL.

This section assumes that all units are in proper working condition and are capable of performing their normal duties. The many controls on the synthesized exciter provide flexibility and ease of operation. To place the exciter into operation readily, a prescribed order of turning on the controls is recommended. In the following tabulation, controls are grouped to simplify operation as much as practical. For identification of controls, see figure I-3-1 for SBG's used with GPT-10K (R) or GPT-40K (E) and figure I-3-2 for SBG's used with SBT-1K (E, F, G, H) transmitters.

I-3-2. TUNING AND LOADING PROCEDURE FOR EXCITER. (See Table I-3-1.)

a. Steps 0-10 in Table I-3-1, indicate a recommended turn-on procedure. From a cold start, the rack should have a warm-up time of 48 hours. The smaller warm-up time assumes STANDBY operation in idle periods. To simplify instructions, a tune up on carrier at 7,001,500 cps is given; tune up at other carrier frequencies should be readily apparent from the 7,001,500 cycle tune-up procedure.

b. Steps 11 and 16 are settings required for the 7,001,500 cps carrier; control 38 in position 1 agrees with the kilocycle digit in 7,001,500; control 41 in position 5 agrees with the hundreds digit in 7,001,500. Steps 11 through 16 indicate check operation of the low frequency loop (CLL).

c. Steps 17 through 27 are to enable the control master oscillator (CMO) to supply the proper output frequency. Reference to figure I-4-8 (section 4) shows that the CMO has an RF output in the 2-4 range. The CMO contains a calibrating circuit of a 100 kc oscillator equipped with a reactance tube, mixer, and beat indicator and phones. By carrying out step 17, the 5.75-7.75 band on control 21 indicates 4, a 4-mc differential. Other differences are indicated in Table I-3-3. Consequently, the CMO must provide 7,001,500 less 4,000,000 or 3,001,500 cps. The nearest check point to 3,001,500 cps is 3,000,000 cps. Consequently, the CMO should be calibrated at 3,000,000 cps as shown by step 19. Steps 20 and 21 merely (a) re-adjust CMO for the approximate 3,001,500 cps output and (b) lock the calibrate adjustment. Steps 22 through 27 (a) tune CMO for the setting in step 20, (b) lock the MASTER OSCILLATOR FREQUENCY dial, and (c) provide a workable synthesized output level from the CMO.

d. At this point, the master oscillator (CMO) output is 3,001,500, the primary standard (CSS) is powered and operating since the divider chain (CHL) and controlled oscillator (CLL) in the low frequency loop are properly functioning; hence the high frequency loop (CHG) only remains to be tuned and properly operated. Perform step 29 to provide the (CHG) with 250 kc carrier. The high frequency loop (CHG) circuits heterodyne the synthesized output from the (CMO) to the desired output frequency. However, the (CHG) balanced modulator needs tuning which is done as shown in step 30. Steps 31 through 34 tune CHG's output circuit for the desired frequency and provide an output level of one watt.

TABLE I-3-1. TUNING/LOADING PROCEDURE FOR EXCITER

Step	Control		Operation	Purpose
	No.	Designation		
0	63	POWER/STANDBY	STANDBY	In turning power on to the equipment, the filaments of all vacuum tubes should be heated before the plates receive voltage. This step and the following nine insures this condition. Before operating the equipment, allow sufficient time for ovens 13, 27 and 49 to cycle. Step 0 will keep the ovens warm without expenditure of plate power; plate power is expended in steps 1 through 9.
	60	B+	STANDBY	
	57, 58	EXCITER	LINE (CH 1, CH 2)	
	45	ON/STANDBY	STANDBY	
	40	SYNC	OFF	
	29	OPERATE/CAL	CAL	
	14	POWER	STANDBY	
16	B+	OFF		
12	ON/OFF	OFF		
1	63	POWER/STANDBY	ON	Supplies power to rack components. Powers TIS-3. Feeds audio on channels directly to CBE.
2	60	B+	ON	
3	57, 58	EXCITER	LINE (CH 1, and CH 2)	
4	45	ON/STANDBY	ON	Powers CSS-1. In preparation for step 18.
5	40	SYNC	OFF	
6	29	OPERATE/CAP	CAL	
7	14	POWER	ON	Powers part of CHG. Powers part of CHG. Powers part of CBE.
8	16	B+	ON	
9	12	ON/OFF	ON	
10	The following is a tune up of synthesized exciter on carrier at 7,001,500 cps output frequency (F out). The procedure for other carrier frequencies is readily apparent from the example given below. Steps 11 through 16 check that the divider chain CLL is properly operating.			
11	38	KILOCYCLES	POSITION 1	Corresponds to the 1-kc increment in the 7,001,500 F out. Corresponds to the 500-cps increment in the 7,001,500 F out. Observes square trace which should be stationary.
12	41	HUNDREDS OF CYCLES	POSITION 5	
13	40	SYNC	L-3	
14	40	SYNC	L-2	Observes square trace which should be stationary. Observes square trace which should be stationary.
15	40	SYNC	L-1	
16	40	SYNC	OFF	
17 18	21, 22 29	MCS, BAND OPERATE/CAL	TURN TO POSITION 4 CALIBRATE AT 3,000,000 CHECK POINT	Covers 5.75-7.75 band (which contains desired tune-up frequency). CMO's output frequency should be 3,001,500 computed as follows: 7,001,500 less 4,000,000 based on the 4 mc BAND POSITION of control 21.

TABLE I-3-1. TUNING/LOADING PROCEDURE FOR EXCITER (Cont.)

Step	Control		Operation	Purpose
	No.	Designation		
19	32b	28 LOCK, CAL/BEAT	ADJUST 32b to MAKE 28 BEAT	CMO is calibrated on 3,000,000 (nearest 50 KC check point to 3,001,500 cycles). CMO frequency output is 3,001,500.
20	34, 35	MASTER OSCIL-LATOR FRE-QUENCY	SET AT 3,001,500	
21	37	LOCK	LOCK CMO	
22	29	OPERATE/CAL	OPERATE	
23	36	OUTPUT	FULL CLOCKWISE	For good reading on meter 30. Further detail on this operation is given in CMO manual Part III (B) and in section 4 of Part I dealing with principles of operation of phase detector circuits. Locks CMO at TUNED FRE-QUENCY. A reading of 30 on meter 30.
24	33	TUNING KCS	TUNE FOR MAXIMUM ON 30	
25	26	SYNC IND	TUNE 32b TO PLACE	
	31	ADJ FOR ZERO	31 in CENTER OF	
	32b	LOCK	SCALE CONCUR-RENTLY WHILE 26 is lit.	
26	32a	LOCK	LOCK	
27	36	OUTPUT	CLOCKWISE TO PRODUCE	
28	The CMO is now tuned by steps 17 through 27 and locked.			
29	8	CARRIER LEVEL	FULL CLOCKWISE	Full center frequency output. Position of 24 should correspond closely with number on control 34.
30	24	MF TUNING	ADJUST FOR MAX. ON METER 19	
31	25	OUTPUT	HALF CLOCKWISE	This operation insures tuning on desired frequency and insures correct output frequency and avoids tuning on a parasitic frequency. Corresponds to one watt.
32	23	OUTPUT TUNING	ADJUST SO THAT 18 DEFECTS TO A POSITION APPROXIMATELY 7,001,500. READJUST SLIGHTLY TO OBTAIN A PEAK READING ON 20	
33	25	OUTPUT	ADJUST FOR READING OF 9 METER ON 20	
34	17	SYNC	LIGHTS WHEN TUNED AND SYNTHESIZED	
35	With audio input intelligence, use controls 6 or 10 and gains 7 or 9 to obtain peak of -10 on controls 4 or 5 with TIS input intelligence, use controls 6 or 10 out gains 7 or 9 to obtain peaks of -10 on controls 4 or 5. Consult instruction book on TIS-3 operation.			
36	25	OUTPUT	ADJUST FOR READING OF APPROXIMATELY 1 on METER 20	Corresponds to 100 milliwatts.

TABLE I-3-2. TABLE OF EQUIVALENT CONTROL DESIGNATIONS

Serial Designation (See figures I-3-1 and I-3-2)	Panel Designation (See figures I-3-1 and I-3-2)	Component Designation on Overall Schematic Diagram		
		Designation	Figure	
4	LSB	M202	Sideband Exciter, CBE, II-8-1	
5	USB	M201		
6	LSB (OFF/CH 1/CH2)	S203		
7	LSB (GAIN)	R222		
8	CARRIER LEVEL	R207		
9	USB (OFF/CH 1/CH 2)	S202		
10	USB (GAIN)	R219		
11	POWER (IND)	I201		
12	POWER (ON/OFF)	S201		
13	OVEN	I1001		Frequency Oscillator, CHG, III(A)-8-1a, -1b, -2
14	POWER (ON/STANDBY)	S1002		
15	STANDBY	I1003		
16	B+ (ON/OFF)	S1001		
17	SYNC	I1002		
18	MCS	4-BAND DIAL		
19	MF TUNING	M1001		
20	OUTPUT	M1002		
21	MCS	16-BAND DIAL		
22	BAND	S1101A,B/S1102A,B/ S1103/S1104/S1105/ S1106/S1402/S1501		
23	OUTPUT TUNING	C1135/C1142/C1151/ C1163		
24	MF TUNING (MCS)	R1003/C1107A,B/ C1113A,B		
25	OUTPUT	R1125		
26	SYNC IND	I304	Controlled Master Oscillator, CMO, III(B)-8-1	
27	OVEN	I301		
28	CAL BEAT	I303		
29	OPERATE CAL	S304		
30	TUNING KCS (TUNE FOR MAX)	M301		
31	TUNING KCS (ADJ FOR ZERO)	M302		
32a,b	a. KNOB (LOCK) b. KNOB (ADJUST)	LOCKS 32b L301		
33	TUNING KCS	C330A through C330D		
34	MASTER OSCILLATOR FREQUENCY DIAL	DIAL		
35	MASTER OSCILLATOR FREQUENCY KNOB	C301/C307		
36	OUTPUT	R321		
37	LOCK	LOCKS 35		
38	KILOCYCLES	S701A through S701D	Controlled Oscillator, CLL, III(E)-8-1	
39	SYNC-SCOPR	V713		
40	SYNC-LOOP	S703A,B		
41	HUNDREDS OF CYCLES	S702A through S702D		

TABLE I-3-2. TABLE OF EQUIVALENT CONTROL DESIGNATIONS (Cont.)

Serial Designation (See figures I-3-1 and I-3-2)	Panel Designation (See figures I-3-1 and I-3-2)	Component Designation on Overall Schematic Diagram	
		Designation	Figure
42 43 44 45 46 47 48	POWER PHASE COMPARATOR SENSITIVITY ON/STANDBY IMC MONITOR STANDBY PRI STD IN	I602 M601 R616 S601 J601 I601 V604	Primary Standard, CSS, III(C)-8-1
49 50 51 52 53 54 55 56 57 58 59 60	OVEN SHIFT CPS LEVEL ADJ OUTPUT LEVEL FSK/FAX/CW 1900/2000/2550/SPARE LINE/MARK/SPACE 50V/100V/20MA/60MA EXCITER (LINE/FSK/ FAX/CW) (CH1) EXCITER (LINE CH 2 FSK/FAX/CW) B+ B+ (ON/STANDBY)	I2 R31 R49A,B M1 S1 S6 S2 S3 S4 S5 I1 S7	Tone Intelligence Unit, TIS-3, IV-8-1

**TABLE I-3-3. TABLE OF RELATIONSHIPS BETWEEN CMO SETTING, FREQUENCY
DIFFERENCE BETWEEN CMO AND RF OUTPUT (POSITION MCS) AND
RF OUTPUT FREQUENCY**

CMO SETTING RANGE/CENTER FREQ.	MCS DIAL SETTING		MODULATOR			
	POS.	FREQ.	INPUT	INPUT	TUNE	OUTPUT
1.75-2.75-3.75	0	1.75-3.75	1.75-2.75-3.75	20	1.75-3.75	1.75-2.75-3.75
1.75-2.75-3.75	2	3.75-5.75	16.25-15.25-14.25	20	3.75-5.75	3.75-4.75-5.75
1.75-2.75-3.75	4	5.75-7.75	16.25-15.25-14.25	22	5.75-7.75	5.75-6.75-7.75
1.75-2.75-3.75	6	7.75-9.75	16.25-15.25-14.25	24	7.75-9.75	7.75-8.75-9.75
1.75-2.75-3.75	8	9.75-11.75	16.25-15.25-14.25	26	9.75-11.75	9.75-10.75-11.75
1.75-2.75-3.75	10	11.75-13.75	1.75-2.75-3.75	10	11.75-13.75	11.75-12.75-13.75
1.75-2.75-3.75	12	13.75-15.75	1.75-2.75-3.75	12	13.75-15.75	13.75-14.75-15.75
1.75-2.75-3.75	14	15.75-17.75	1.75-2.75-3.75	14	15.75-17.75	15.75-16.75-17.75
1.75-2.75-3.75	16	17.75-19.75	1.75-2.75-3.75	16	17.75-19.75	17.75-18.75-19.75
1.75-2.75-3.75	18	19.75-21.75	1.75-2.75-3.75	18	19.75-21.75	19.75-20.75-21.75
1.75-2.75-3.75	20	21.75-23.75	1.75-2.75-3.75	20	21.75-23.75	21.75-22.75-23.75
1.75-2.75-3.75	22	23.75-25.75	1.75-2.75-3.75	22	23.75-25.75	23.75-24.75-25.75
1.75-2.75-3.75	24	25.75-27.75	1.75-2.75-3.75	24	25.75-27.75	25.75-26.75-27.75
1.75-2.75-3.75	26	27.75-29.75	1.75-2.75-3.75	26	27.75-29.75	27.75-28.75-29.75
1.75-2.75-3.75	28	29.75-31.75	1.75-2.75-3.75	28	29.75-31.75	29.75-30.75-31.75
1.75-2.75-3.75	30	31.75-33.75	1.75-2.75-3.75	30	31.75-33.75	31.75-32.75-33.75

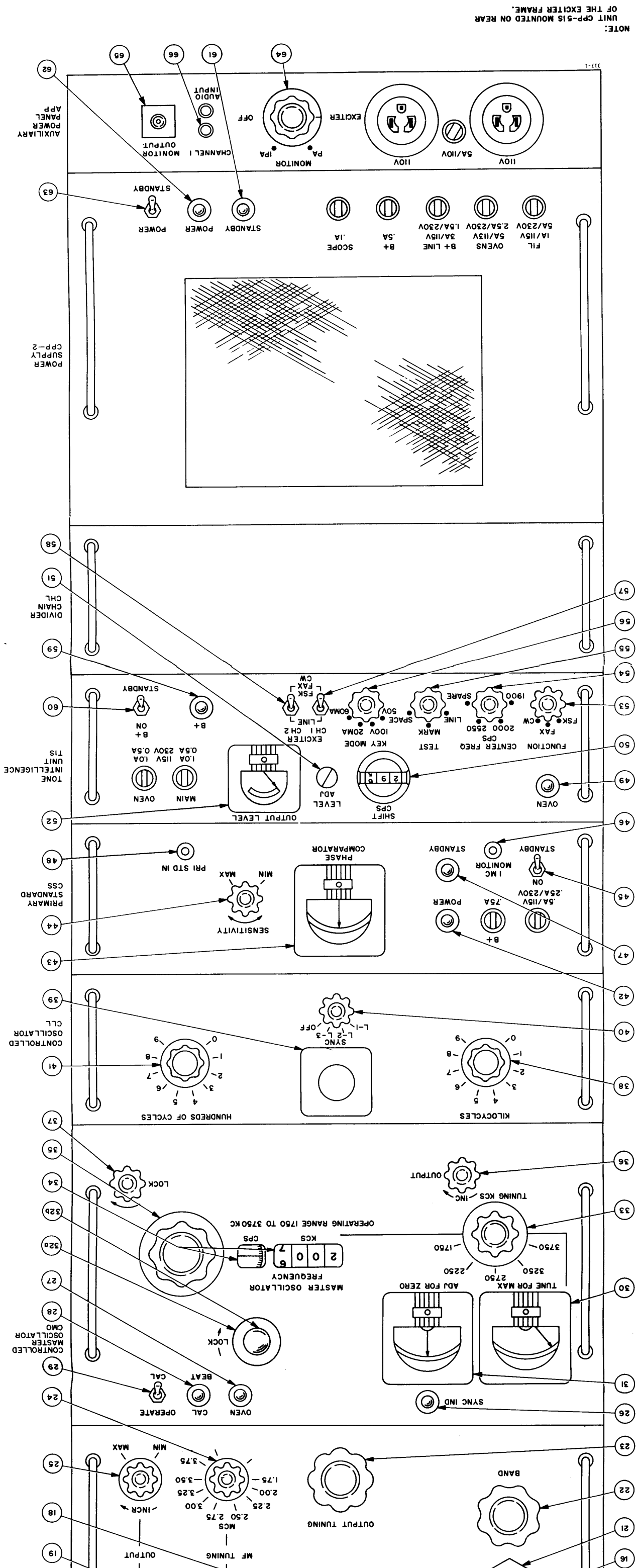
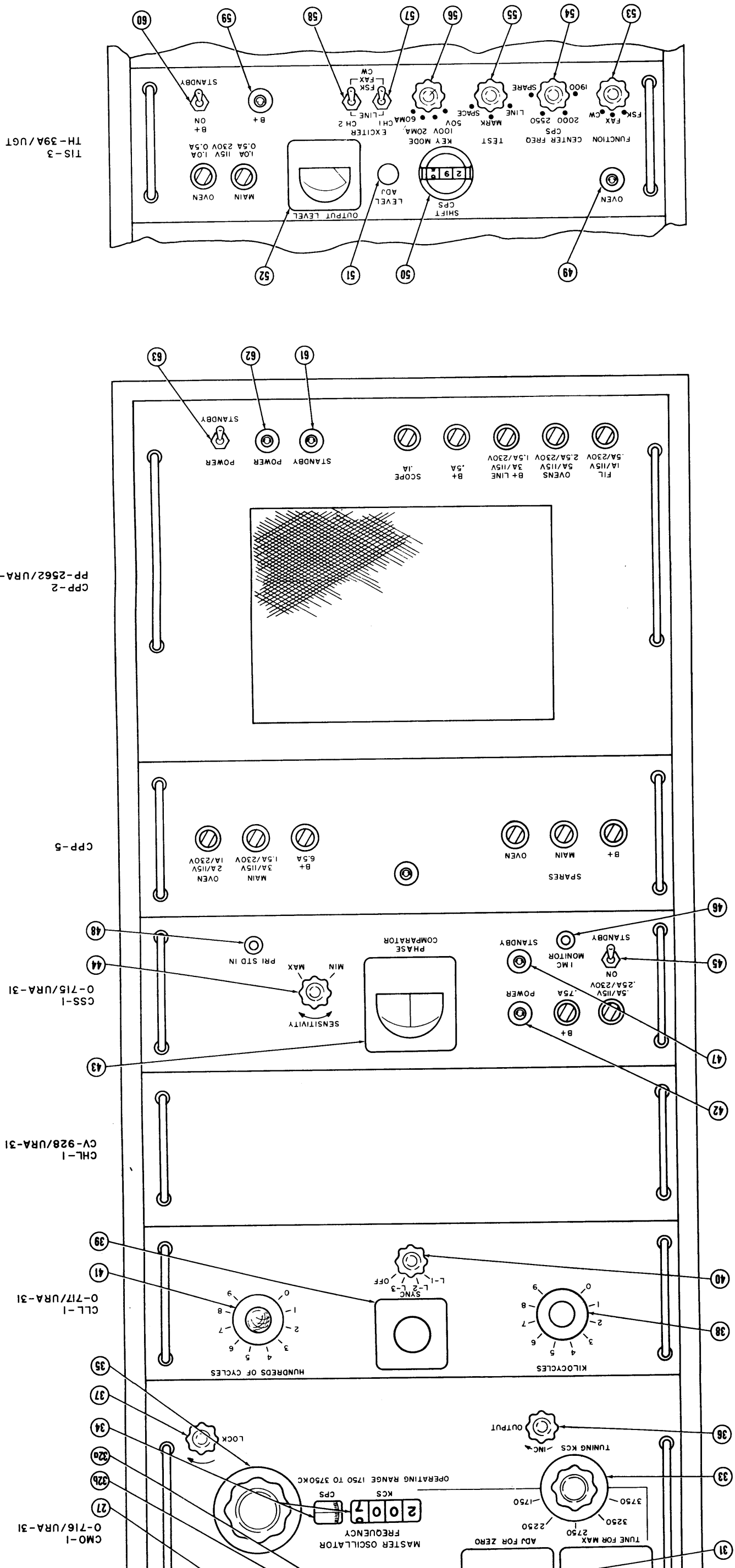

Figure I-3-1. Location of Controls on Sideband Generator p/o GPT-10K(R) or GPT-40K(E)

317-1
20165220

Figure I-3-2. Location of Controls on Sideband Generator p/o SBT-1K (E, F, G, H)

NOTE: TONE INTELLIGENCE UNIT MODEL TIS-3 IN SBT-1K(E) IS LOCATED ON A SECOND RACK AT RIGHT OF CONTROLLED MASTER OSCILLATOR MODEL CMO (SEE FIG I-1-1P). TIS-3'S CONTROLS ARE SHOWN ABOVE.



TIS-3 TH-39A/UGT

CPP-2 PP-2562/URA-31

CPP-5

CSS-1 0-715/URA-31

CHL-1 CV-928/URA-31

CLL-1 0-717/URA-31

CMO-1 0-716/URA-31

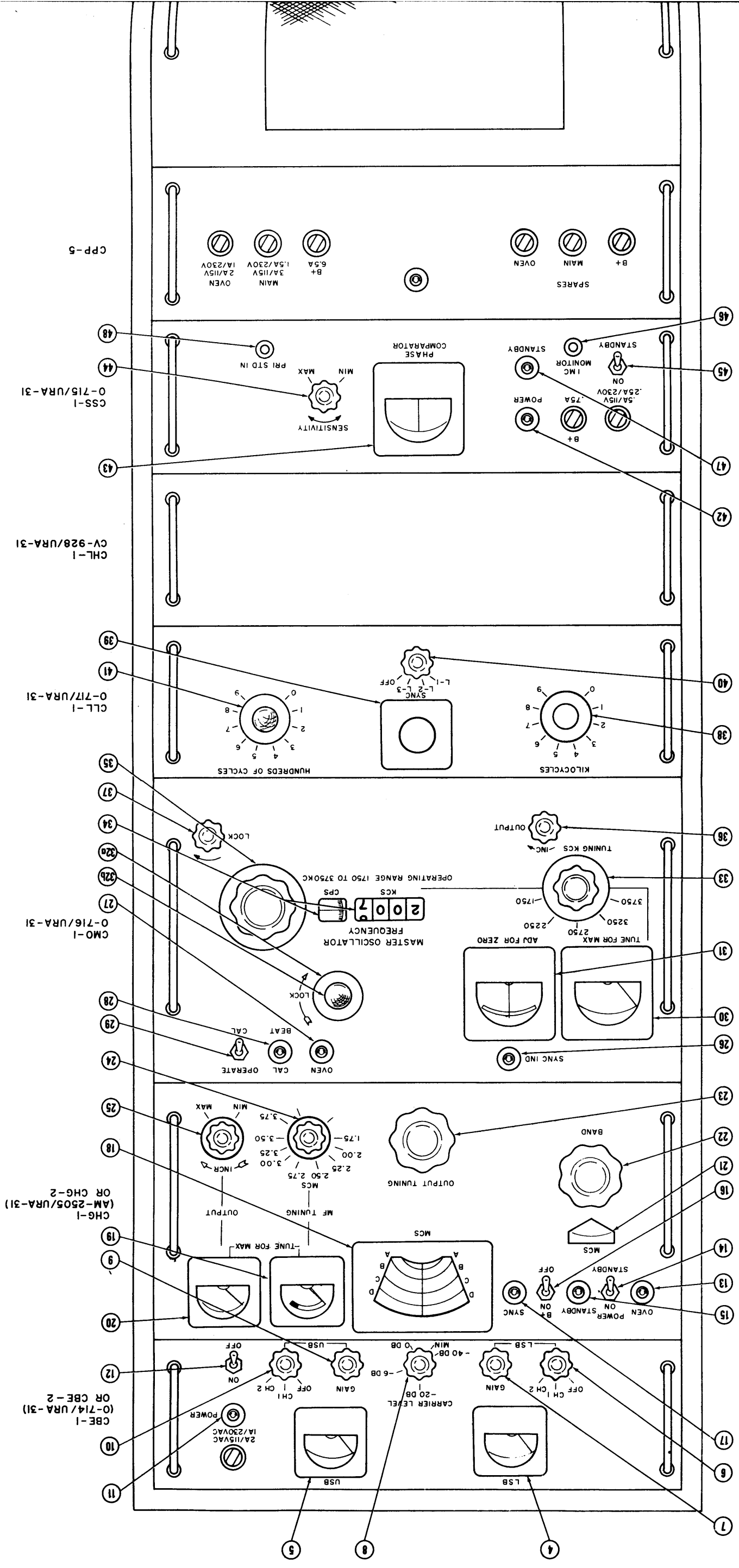

SECTION 4

PRINCIPLES OF OPERATION

I-4-1. GENERAL.

As indicated in the Table of Contents of this manual, the synthesized exciter is described in Parts I through IV as follows:

Part	Section	Description
I	4	By block diagrams of basic equipment units.
II	4	By stage-by-stage simplified schematics of CBE unit.
III	4	By stage-by-stage simplified schematics of CPO units.
IV	4	By stage-by-stage simplified schematics of TIS units.

Parts II, III, and IV, section 8, present schematic diagrams of over-all equipment units. The block diagrams descriptions in Part I present a quick over-all picture of the functioning of each unit. However, to facilitate understanding, some general remarks are pertinent.

a. AUTOMATIC PHASE CONTROL SYSTEM.

As shown in following figure I-4-1, this system contains an oscillator with a nominal frequency equal to the desired output frequency; some form of reactance modulator or other means of voltage control of the oscillator frequency; a phase detector which compares the outputs of the oscillator and the reference source; and a low-pass filter which filters the output voltage of the phase detector before it is applied to the reactance modulator.

The operation of the system can be understood qualitatively by assuming that the oscillator frequency is equal to that of the reference. The phase-detector output is then a DC voltage dependent of the phase difference between the output signals of the oscillator and the reference. This voltage is applied through the low-pass filter to the reactance modulator and thereby governs the oscillator frequency. If the oscillator frequency tends to change, this attempted change is first felt as a phase-difference change in the phase detector. This produces a change in phase-detector output voltage which acts to hold the oscillator frequency constant. As the oscillator drifts, its output phase, relative to that of the reference, will drift but its average

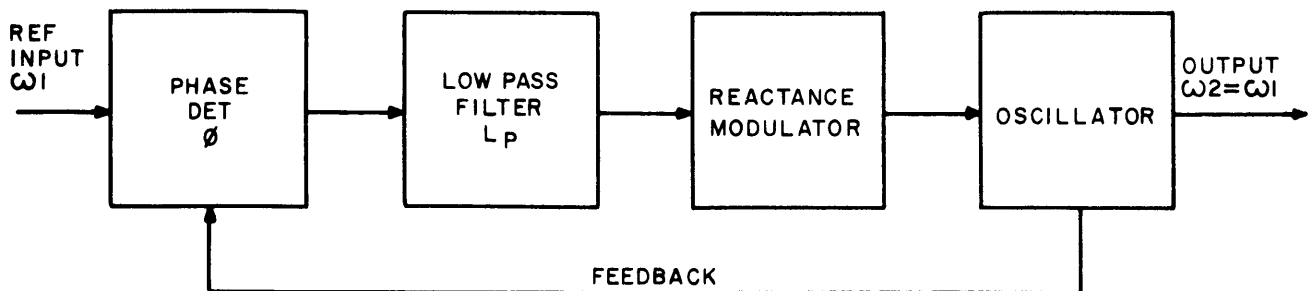

Figure I-4-1. Block Diagram of an Automatic Phase Control System

frequency will remain fixed. The system operates exactly like a positional servo-mechanism wherein, for constant input position, the output position is exactly equal to the input, with zero steady-state error.

b. PHASE DETECTOR CIRCUIT.

As shown in following figure I-4-2, voltage V1 produces voltage E1 across the potentiometer R. When terminal 3 is positive relative to terminal 4, the diodes conduct and present relatively low impedance; when terminal 3 is negative relative to terminal 4, the diodes are non-conducting and present a very high impedance. This aspect is pictured in the top graph of I-4-2.

Now, let V2's frequency be the same as V1's frequency but V2's phase be 90 degrees behind V1's phase. For clarity, V2's zero axis (figure I-4-2) is displaced below V1's zero axis. During the first and third half cycles of V1, V2 "sees" G through the relatively low impedance of the diodes. During the second and fourth half cycles of V1, V2 "sees" G through the very high impedance of the diodes. The wave shape of E2 is as shown with unequal positive and negative areas

of voltage at the LP filter's input. To obtain graph E2, pictured as the second graph of I-4-2, note that when the diodes are conducting, V2's external impedance "consumes" most of the voltage, leaving E2 negligibly small; however, when the diodes are non-conducting, E2 becomes relatively large.

Now, let V2's frequency be the same as V1's frequency but V2's phase be 135 degrees behind V1's phase. For clarity, V2's zero axis is further displaced below V1's zero axis. Again, during times 0 T1 and T2T3, when the diodes are conducting, the value of E2 is substantially zero. During times T1T2 and T3T4, when the diodes are non-conducting, the value of E2 is positive or negative depending upon phase. The wave shape of E2 is as shown with unequal positive and negative areas of voltage at the LP filter's input.

c. FREQUENCY TRANSLATIONS IN HIGH FREQUENCY AND LOW FREQUENCY LOOPS.

Figure I-4-3 is a block diagram illustrating a particular procedure of frequency translations in high frequency and low frequency loops. The

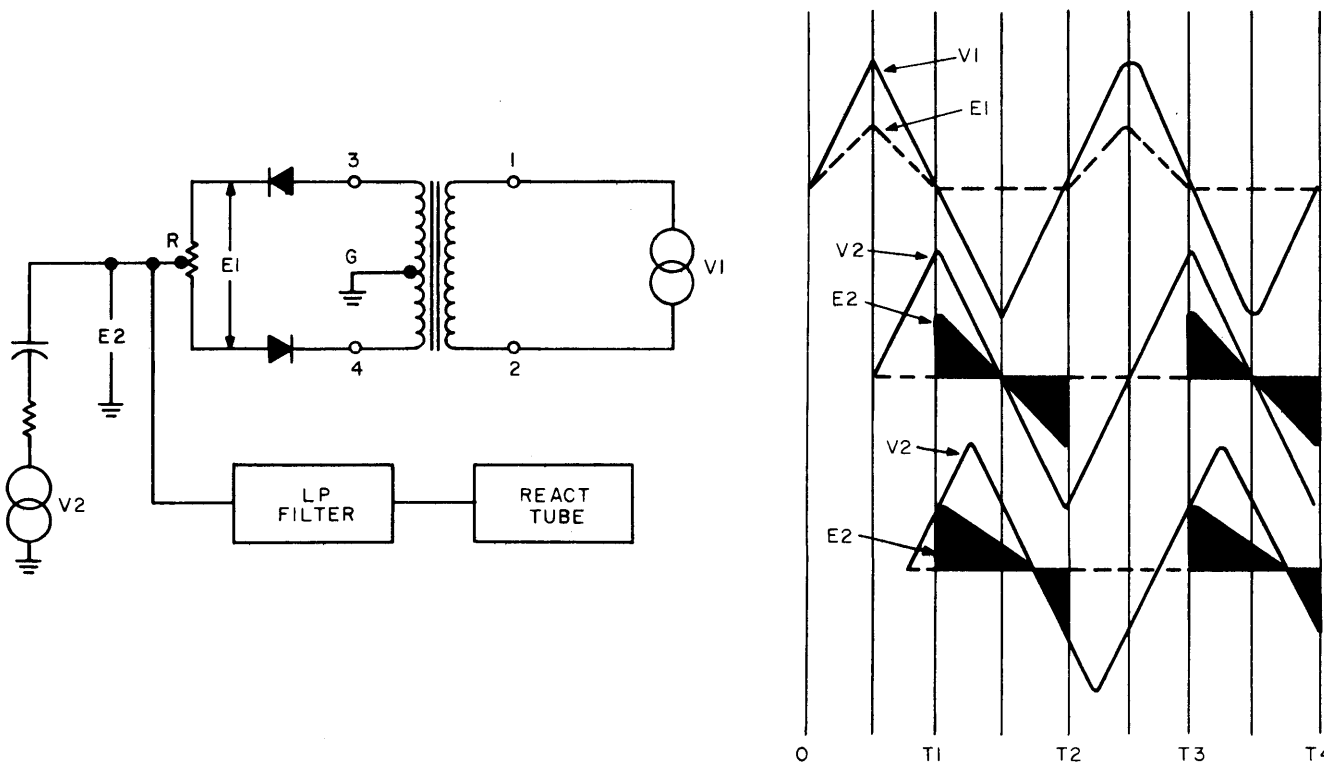

Figure I-4-2. Simplified Schematic Diagram Illustrating Operation of Phase Detector Circuit Used in Controlled Precision Oscillator

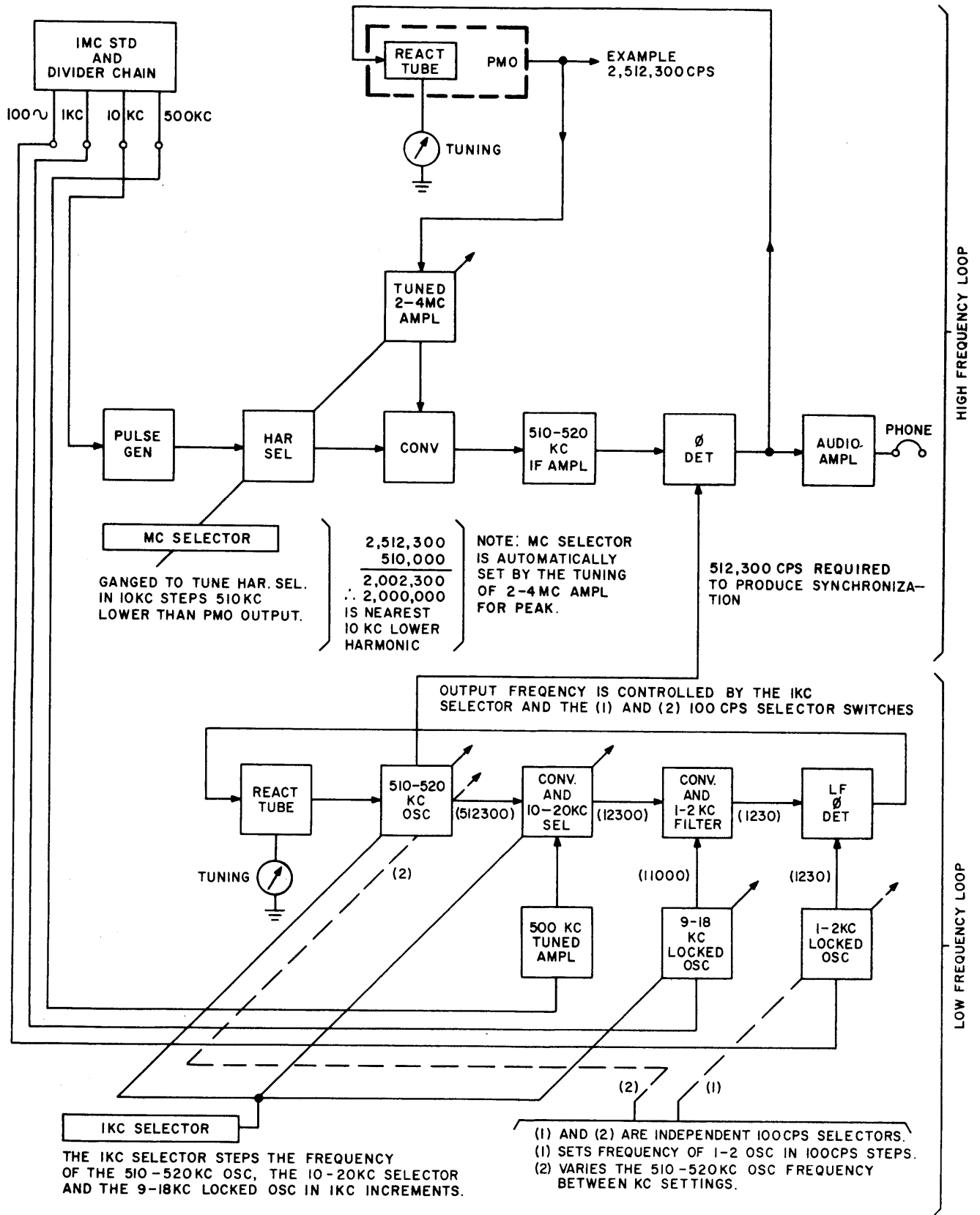

Figure I-4-3. Block Diagram Illustrating Frequency Translation in High Frequency and Low Frequency Loops

procedure used in the SBG differs in its details from that shown on figure I-4-3; however, this is of small importance in the general understanding of the SBG, as will be seen from the discussions presented in later paragraphs.

To simplify the analysis, assume that the PMO's output is to be exactly 2,512,300 cps. The output of the PMO is fed to the CONV via the TUNED 2-4 MC AMPL. The output of the CONV is fed to the 510-520 KC IF AMPL. When the TUNED 2-4 MC AMPL is tuned for a peak reading of 2,512,300 the HAR SEL is gang-tuned to 2,000,000 in order to present the 510-520 KC AMPL. with a 510-520 kc modulation product. For example, assume the HAR SEL is gang-tuned to its next 10-kc harmonic, namely, 2,100,000. Now the 510-520 KC AMPL. would receive a 2,512,300 less 2,010,000 or 502-300 kc modulation product, which would not pass through the sharply tuned 510-520 KC IF AMPL. This result is obtained by tuning the TUNED 2-4 MC AMPL for a peak reading by the MC SELECTOR knob, which simultaneously (1) peaks the amplifier's output and (2) selects the PULSE GEN's 10-kc harmonic of 510-520 kc below the PMO's frequency; in the case at hand 2,000,000 cps. Thus one terminal of the PHASE DET receives an unsynthesized 512,300 cps. To adjust the PMO's frequency to exactly 2,512,300 cps, the low frequency loop must provide the PHASE DET with a voltage of exactly 512,300 cps. The PHASE DET DC output, thereby, adjusts the PMO's frequency to exactly 2,512,300 cps via its REACT TUBE.

It now remains to see how the low frequency loop provides the high frequency loop PHASE DET with a voltage of exactly 512,300 cps. The low frequency loop's CONV AND 10-20 KC SEL heterodynes two incoming voltages: one from the phase-locked 510-520 KC OSC and the other from a precision 500-kc standard via the 500 KC TUNED AMPL. If the 1 KC SELECTOR is set for 2 kc and the 100 cps SELECTOR is set for 300 cps, the system is stabilized only when both inputs to the LF PHASE DET have frequencies of 1300 cps. With a 2-kc setting of the 1 KC SELECTOR, the 9-18 KC LOCKED OSC has output frequency of 11 kc. Therefore, the output frequency of the CONV & 10 SEL must be 12,300 cps and the output frequency of the phase-locked 510-520 KC OSC must be 512,300 cps.

d. FREQUENCY DIVISION BY PHANTASTRONS.

Frequency division is sometimes obtained by driving a multivibrator with a synchronizing

voltage well beyond the multivibrator's natural frequency. As an attempt is made to pull the multivibrator to higher and higher frequencies, a limit is reached beyond which the multivibrator synchronizes to one half of the driving frequency. Similarly, the multivibrator may synchronize to one-third or even a smaller fraction of the driving frequency. The advantage of the phantatron delay multivibrator over the usual types of delay circuits or multivibrators is the direct relationship between the controlling voltage and the delay time as compared to an exponential relationship in the usual circuits.

A phantatron circuit composed of a single multigrid tube may be considered the equivalent of a two-tube circuit wherein one tube consists of the cathode, control grid A, and shield grid (acting as plate) and the other tube consists of the cathode, control grid B, and plate. As the cathode is common to "both" tubes, the electrons going to the plate are controlled by both grid B and grid A. The cumulative effect causes the plate voltage to decrease at a relatively slow and linear rate as shown in the following wave shape diagram.

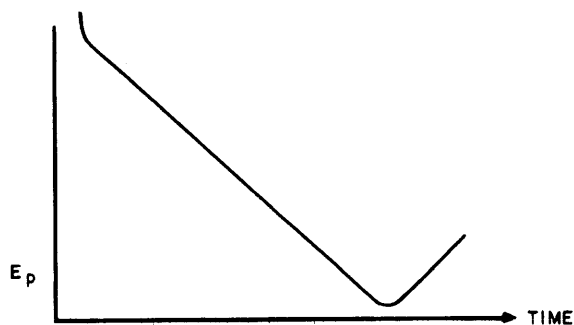

PLATE VERSUS TIME CHARACTERISTIC OF PHANTASTRONS (FREQUENCIES DIVISION IN SBG UNIT)

I-4-2. SIDEBAND EXCITER, MODEL CBE-1.

(See figure I-4-4.)

The CBE-1 accepts two channels of intelligence (each having a bandwidth of 7.5 kc) and processes them for sideband transmission in the 250-kc frequency range. Block diagram, figure I-4-4, shows how the result is accomplished. Part II, section 4 of the manual presents stage-by-stage descriptions based on simplified schematic diagrams. Over-all schematic diagram, figure II-8-1, elaborates on the technical details.

Audio-frequency amplifiers V203 and V207 (figure I-4-4) receive intelligence in channels 1 and/or 2. This intelligence is either speech or telegraph (FSK, FAX, CW) which is frequency

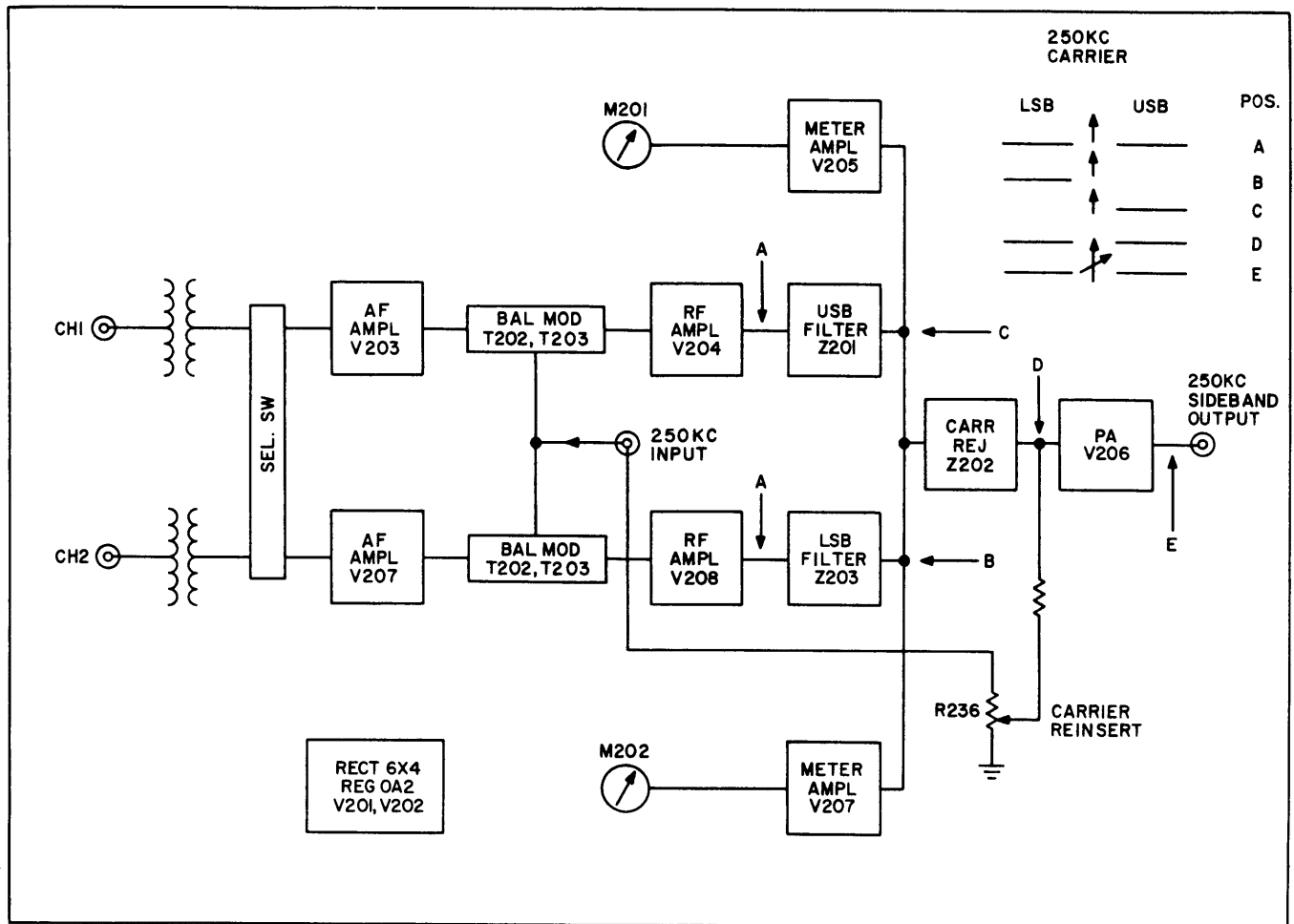

Figure I-4-4. Sideband Exciter, CBE-1

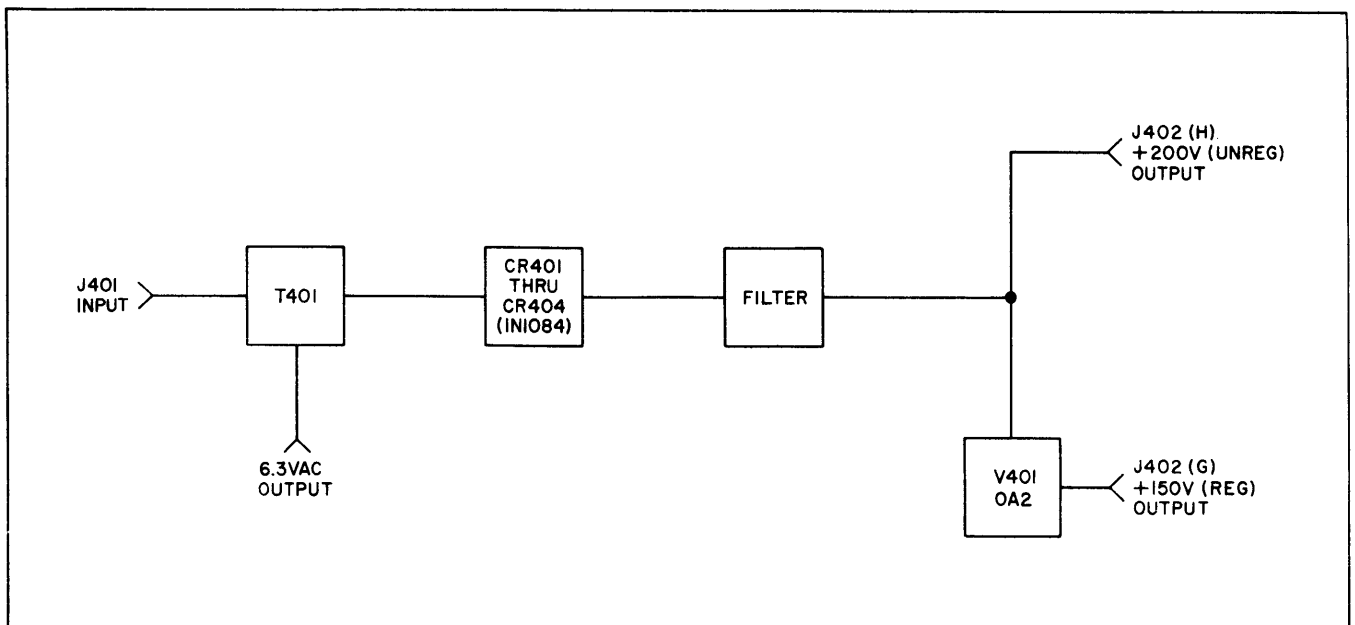

Figure I-4-5. Power Supply, CPP-1

translated into audio by associated TIS unit). The audio frequency inputs are frequency translated into sidebands around 250-kc carrier by the 250-kc carrier input supply and sideband modulators, amplifiers, and filters. The output of the carrier rejection network Z202 contains the two 7.5 kc bandwidths of intelligence with the 250-kc carrier rejected, unless the carrier is re-inserted by CARRIER REINSERT resistor R236. Power amplifier PA206 raises the power output to one watt (PEP). Meters M201 and M202 monitor levels to guard against distortion. The exciter has a self contained power supply.

The diagram in the upper right corner of figure 1-4-4 indicates, on a non-quantitative basis, what a spectrum analyzer would show at the points indicated. For example, at the outputs of RF AMPL V204/V208 a spectrum analyzer would show energy peaks per reference A. At the output of Z203, energy peaks per reference B. At the output of Z201, energy peaks per reference C. At the output of Z202, energy peaks per reference D. At the output of V206, energy peaks per reference E.

I-4-3. POWER SUPPLY, MODEL CPP-1.

(See figure I-4-5.)

The power supply for component CHG (mounted behind CHG on rear frame) supplies 200-volt unregulated and 150-volt regulated outputs. Block diagram, figure I-4-5, shows how the result is accomplished. Part III(A), section 4 of the manual, presents stage-by-stage descriptions and figure III(A)-8-2 is CPP-1's over-all schematic.

I-4-4. FREQUENCY AMPLIFIER, MODELS CHG-1 OR -2 (HIGH FREQUENCY LOOP).

(See figures 1-4-6 and 1-4-7.)

Refer to paragraph I-4-1.c in this part of the manual for the role played by SBG's Frequency Amplifier model CHG (high frequency loop). Block diagrams, figures I-4-6 and I-4-7, show the techniques used and schematic diagrams, figure III(A)-8-1a and -1b, show the details.

Refer to figure I-4-6. The output of the high frequency loop on BAND SWITCH position 1, is 1.75 to 3.75 mc; on BAND SWITCH position 2, 3.75 to 5.75 mc; and finally on BAND SWITCH position 16, 31.75 to 33.75 mc. Reference to Table I-3-3 shows that the associated control master oscillator (CMO) setting is obtained by direct subtraction of the DIAL numeric from the

desired RF OUTPUT FREQUENCY. For example, for an RF output frequency of 18.75 mc, the MCS BAND switch is in position 9, the MCS DIAL numeric is 16 and, therefore, the CMO frequency is 2.75 mc.

Inside CHG's finely-engineered oven are crystals and capacitors which are closely associated with an external high-frequency oscillator (HFO) V1303/V1304 and vari-capacitor C1319. The megacycle output (A mc) of V1303/V1304 ranges from 9 and 16 in precise megacycle frequencies (see note 1 of figure I-4-6), under control of a synthesized feedback loop and vari-capacitor C1319, a solid-state device, whose capacitance varies with d-c input. The oven and oscillator chassis also contains 1-mc components comprising a spare "internal" 1-mc oscillator (V1302A), a 1-mc amplifier (V1302B) for J1303 and J1304, and a second 1-mc amplifier (V1303) for J1302. A more detailed block diagram for the CHG than figure I-4-6 is given on figure I-4-7; complete details are given on schematic diagram figure III(A)-8-1a and -1b.

The synthesizer chassis comprises incoming 1 mc and A mc input circuits, a 2 mc output circuit and a phase-detector d-c feedback circuit that controls the impedance of vari-capacitor C1319 mentioned in the preceding paragraph. Again, figure I-4-7 elaborates on figure I-4-6. The function of the synthesizer is to stabilize two CHG's outputs, namely 2 mc and A mc, based on CHG's 1-mc precise (standard) input. The components of the synthesizer comprise isolation amplifier (V1501), harmonic generator (V1502), mixer (V1508), synchronizing indicator (V1504), doubler (V1505), and phase detector (T1501). These components are conventional and require no explanation except, perhaps, phase detector circuit T150, which is covered in preceding paragraph I-4-1.b.

The IF chassis consists of incoming 2-mc and 1.75-3.75-mc circuits and an outgoing 14.25-16.25-mc circuit. The IF chassis contains an 18-mc generator V1201, an 18-mc amplifier V1202, a balanced modulator (CR1201, 1202), and 14.25-16.25 amplifiers V1204, V1205, and V1206. The arrangement is shown on figure I-4-7; methods of operations are conventional.

The mid-frequency and HF chassis has four inputs and two outputs as follows:

a. 2-4 mc from controlled master oscillator CMO, described in following paragraph I-4-5.

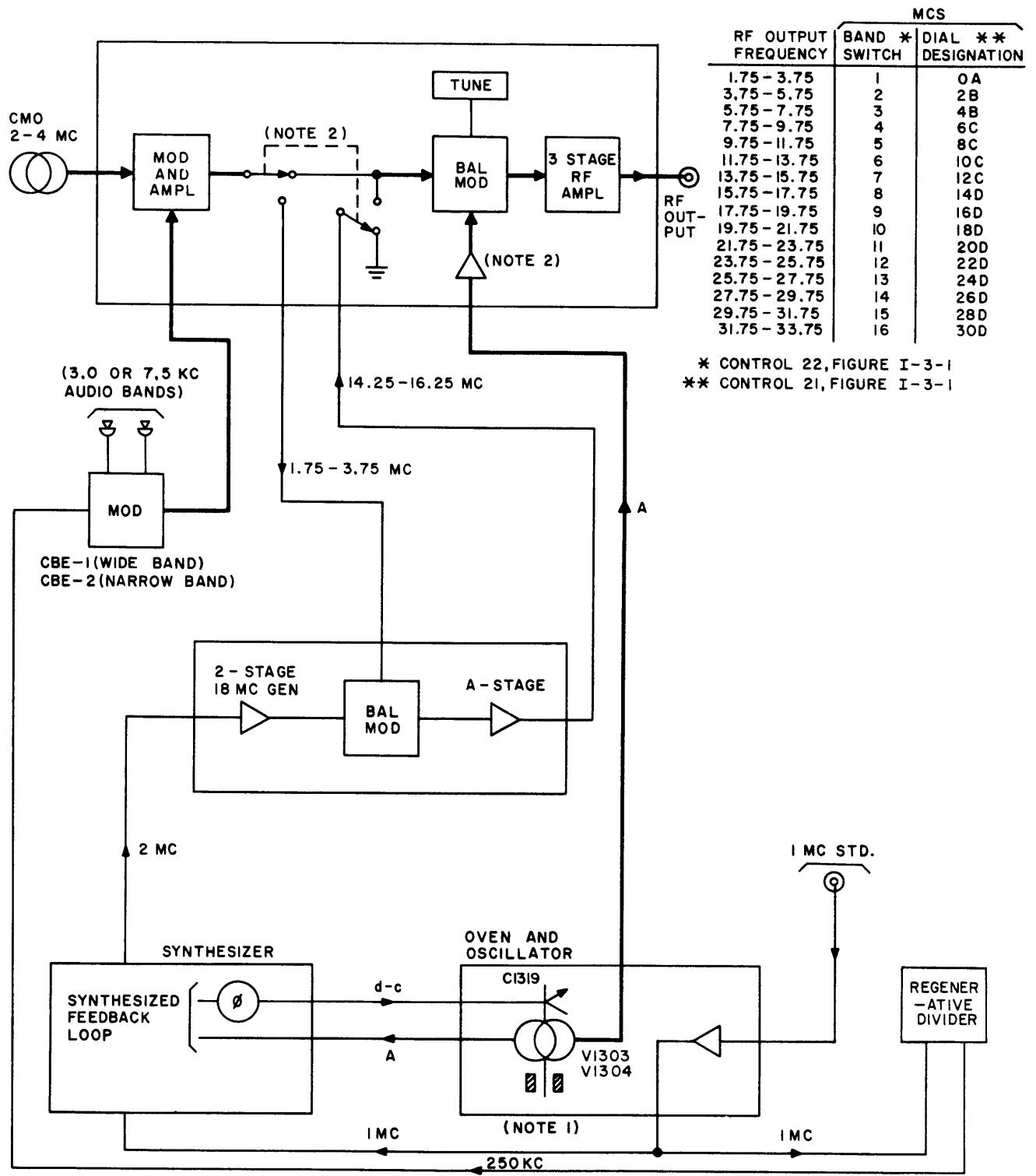

NOTE 1: BAND 1 2 3 4 5 6 7 8 9 10 11 12 13 14 15 16
A (MC) 10 10 11 12 13 10 12 14 16 9 10 11 12 13 14 15.

NOTE 2: OUTPUT OF AMPLIFIER A MC ON BANDS 6, 7, 8, AND 9;
2A MC ON BANDS 1, 2, 3, 4, 5, 10, 11, 12, 13, 14, 15 AND 16.

NOTE 3: SW AS SHOWN ON ALL BANDS EXCEPT 2, 3, 4, AND 5.

Figure I-4-6. Amplifier, CHG-1 or -2 (Component of SBG-1)

b. 250-kc sidebands from CBE, described in preceding paragraph.

c. Outgoing 1.75-3.75 mc sideband intelligence for frequency translation by IF chassis into the 14.25-16.25-mc frequency range.

d. Incoming 14.25-16.25-mc sideband intelligence per preceding item c.

e. Incoming A mc from the high frequency loop CHG in accordance with preceding paragraphs.

f. 1.75-33.75-mc outgoing sideband intelligence to associated sideband transmitter.

Once more, use the 18.75 mc example cited above in order to picture the frequency translations that occur in the CHG. For the 18.75-RF output, the CMO's frequency is 2.75 mc (actually 2.50 mc to allow for CBE's incremental 250-kc input). Note 1 shows A mc to be 16 mc in MCS BAND switch position 9. Note 2 shows BAL MOD input is 16 mc. Note 3 shows that BAL MOD other input is 2.75 since the IF chassis is not used in this operation. Consequently, CHG's RF output is $16.00 + 2.75 = 18.75$ mc as desired.

As a second example, take an 8.25-RF output. In this case the CMO's frequency is 8.25 -6.00 or 2.25 mc. Note 1 shows A mc to be 12 mc in MCS BAND switch position 4. Note 2 shows BAL MOD input is 2A or 24 mc. Note 3 shows that BAL MOD other input via IF chassis is 18 -2.25 or 15.75 mc. Consequently, CHG's RF output is 24.00 -15.75 or 8.25 mc as desired.

I-4-5. CONTROLLED MASTER OSCILLATOR, MODEL CMO-1. (See figure I-4-8.)

As shown by figure I-4-6, controlled master oscillator CMO, when frequency stabilized, together with its companion sideband exciter CBE, supplies precise voltages in the 1.75- to 3.75-mc range. These voltages are frequency translated subsequently in the CHG unit by additional precise heterodyning voltages in order to bring the final RF output product into the 1.75- to 33.75-mc range for use by an associated sideband transmitter. As previously stated the basic 1.75- to 3.75-mc voltages are derived from a precise 1-mc standard.

Figure I-4-8 shows the method by which controlled master oscillator CMO is frequency stabilized. Five circuits are of particular interest:

a. V301, 1/2 V302, V304, V305, RF OUT (see heavy solid line): This circuit, frequency stabilized as explained in following items b, c, and d, is the CMO's output to CHG.

b. V301, 1/2 V302, V304 VS 1/2 V302 to V312, V311, IND (see heavy dotted line): This circuit provides the CMO with 50 kc check points by comparing item a. with CMO's 100-kc secondary standard.

c. 2-4-mc loop V301, 1/2 V302, V304 and V309 VS V306, V307 and V309 to V308 and V310 (see heavy dash-dot line): This circuit supplies the phase detector with a 510-520-kc frequency difference between the MO and one of CHL's 10-kc harmonics.

d. Precise 510-519.9 input from CLL to V310 (see heavy dash-double-dot line): The phase detector's phase comparison of the (i) 510-520-kc frequency difference between the MO and one of CHL's 10-kc harmonics (item c.) and (ii) the precise 510-519.9 input from CLL, locks in the MO to the desired 2-4-mc frequency, even though the comparison is made at an intermediate frequency.

To clarify CMO's operation further, consider the following example.

(1) Desired input to associated transmitter: 10,123,400 cps.

(2) CMO's free-running frequency, when un-synthesized, is one cps below the desired synthesized frequency.

(3) Figure I-4-6 shows that CMO's synthesized frequency should be 10,123,400 less 8,000,000, or exactly 2,123,400 cps.

(4) Initially, MIXER V309 receives 2,123,401 cps (for a very small fraction of a cycle, say for several degrees) from the MO. MIXER V309 heterodynes (for a peak) with CHL's 161 10-kc harmonic, giving an output frequency of 2,123,401 less 1,610,000 or 513,401 cps (for the corresponding small fraction of a cycle) which is readily passed by IF AMPL V308 to the phase detector V310.

(5) A second input to the phase detector V310 arrives, via the 510-519.9-kc output of the CLL. The CLL's output is a precise 513,400 cps.

(6) The phase detector V310 now receives the un-synthesized and synthesized frequencies

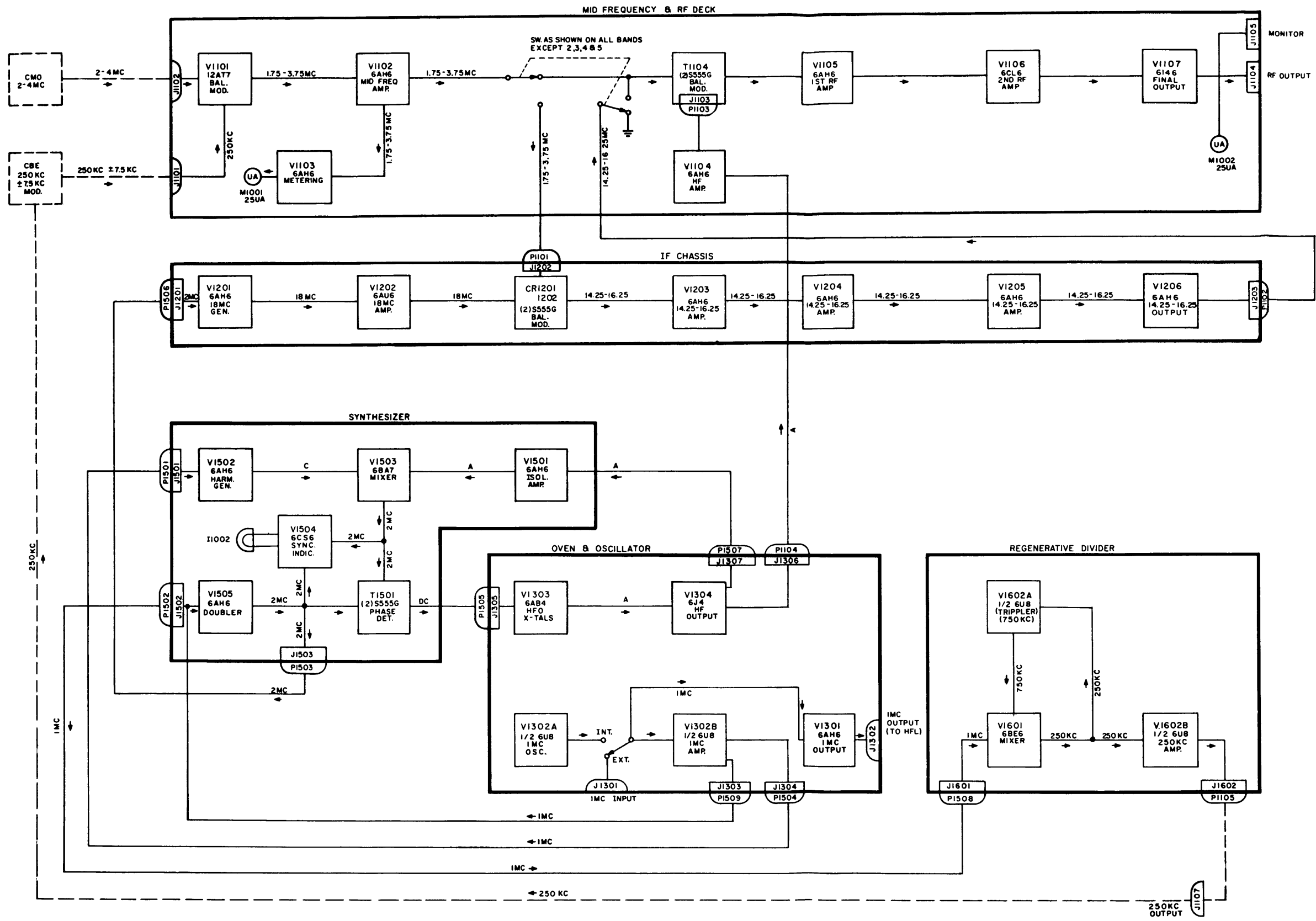

A X-TAL OSC. FREQ. MC.	B HF AMP. MC.	C HARMONIC GENERATOR MC.	RF OUTPUT FREQUENCY MC.	BAND NO.
10	20	8	1.75 - 3.75	1
10	20	8	3.75 - 5.75	2
11	22	9	5.75 - 7.75	3
12	24	10	7.75 - 9.75	4
13	26	11	9.75 - 11.75	5
10	10	8	11.75 - 13.75	6
12	12	10	13.75 - 15.75	7
14	14	12	15.75 - 17.75	8
8	16	6	17.75 - 19.75	9
9	18	7	19.75 - 21.75	10
10	20	8	21.75 - 23.75	11
11	22	9	23.75 - 25.75	12
12	24	10	25.75 - 27.75	13
13	26	11	27.75 - 29.75	14
14	28	12	29.75 - 31.75	15
15	30	13	31.75 - 33.75	16
S 1402	S 1102	S 1501	S 1101A S 1101B	

Figure I-4-7. Block Diagram, High Frequency Loop, CHG

of 513,400 cps, whose phase difference slips from 90 degrees for the small fraction of the cycle being considered.

(7) Because of the departure of the two 513,400 cps components from quadrature, phase detector V310's output is now a d-c voltage which will "pull" the MO to its correct synthesized frequency of 2,123,400, which will become 10,123,400 at the output of the CHG unit.

e. The phase detector's d-c output synchronizes the MO for the desired synthesized RF OUT frequency.

CMO's 2-4-RF output may be conveniently checked at 50-kc check points against the secondary 100-kc standard. This facilitates initial settings of frequency controls and guards against erroneous tuning.

I-4-6. CONTROLLED OSCILLATOR, MODEL CLL-1 (LOW FREQUENCY LOOP)

(See figure I-4-9.)

Refer to paragraph I-4-1.c in this part of the manual for the role played by SBG's low frequency loop, controlled oscillator model CLL-1. Block diagram, figure I-4-9, shows the techniques used in SBG, and schematic diagram, figure III(E)-8-1, shows details.

Controlled Oscillator Model CLL-1 consists of three loops L1 (1000-1900 cps in 100-cps steps), L2 (9-18 kc in 1-kc steps), and L3 (510-519.9 kc in 100-cps steps), in addition to a monitoring oscilloscope circuit. The end product of CLL-1 is voltages in 100-cps steps in the range 510-519.9 kc. These voltages are fed to the CMO's phase detector (V310) to frequency-stabilize CMO's 2-4 mc RF output in the 100-cycle and 1000-cycle digit frequencies. Refer to figure I-4-8.

In the L1 loop, two frequency-precise incoming frequency-divided voltages of 100 cps and 10 kc from the divider chain (CHL-1) are used to provide the L3 loop with precise 100-cps voltages in the variable 1-1.9-kc range. Converter V707 is fed by a 10 kc-precise voltage, as well as a reactance-tube-controlled 11-11.9 oscillator output voltage. The phase detector's assembly compares the converter's 1-1.9-kc product with the proper 100-cps harmonic (100-cps input and harmonic selector V705). The 11-11.9 oscillator's frequency feedback circuit, comprising the above-referenced precise 100-

cps harmonic selector, phase detector, and reactance tube V706A, enables V706B to supply converter V707 with precision voltages as desired in the 11-11.9-kc range in 100-cps steps. Selector switch S702 is the operator's means employed to obtain this end result.

In the L2 loop, precise 9-18-kc frequencies are produced by oscillator V702B amplifier V703A by means of a frequency-controlled feedback circuit referenced by divider chain CLL's 1-kc standard. Refer to paragraph I-4-1.a for a technical explanation. Selector switch S701 is the operator's means employed to select the precise 1-kc voltage wanted by the L3 loop, in the 9-18 kc frequency range.

In the L3 loop, the products of the L1 and L2 loops are utilized to obtain precision voltages as desired in the 510-519.9-kc range in 100-cps steps. As shown in figure I-4-8, this range of precision voltages is supplied to the Controlled Master Oscillator CMO-1. Thus the low frequency loop CLL-1 controls CMO's output, frequency-precise, in the 2-4-mc range in 100- and 1000-cps steps; the high frequency loop CHG-1 (figure I-4-6) frequency-translates the 2-4-mc voltages to 1.75-33.75-mc RF OUTPUT voltages. These are adequate to excite an associated transmitter operating in the 2-32-mc range.

The 510-520-kc oscillator is under frequency control of reactance tube V708A and selector switches S701, S702. Its output feeds converter V709 which also receives a 500-kc frequency-precise voltage from divider chain CLL. The converter's output, therefore, is a voltage in the 10-20-kc range which is fed to a second converter V704 that also receives a 9-18-kc frequency-precise voltage from loop 2 of CLL-1. V704's output, therefore, is a voltage in the 1-2-kc range which goes to a phase detector assembly for comparison with the 1-1.9-kc frequency-precise voltage from loop 1 of CLL-1. The reactance tube synchronizes the system so that the 510-519.9-kc output at jack V703 is proper for reception by the high frequency group CHG.

A fourth feature of the CLL is a test oscilloscope to monitor the products of phase detectors in the L1, L2, and L3 loops.

I-4-7. PRIMARY STANDARD MODEL CSS-1.

(See figure I-4-10.)

The heart of the CSS-1 is a precision oscillator within an oven containing transistors,

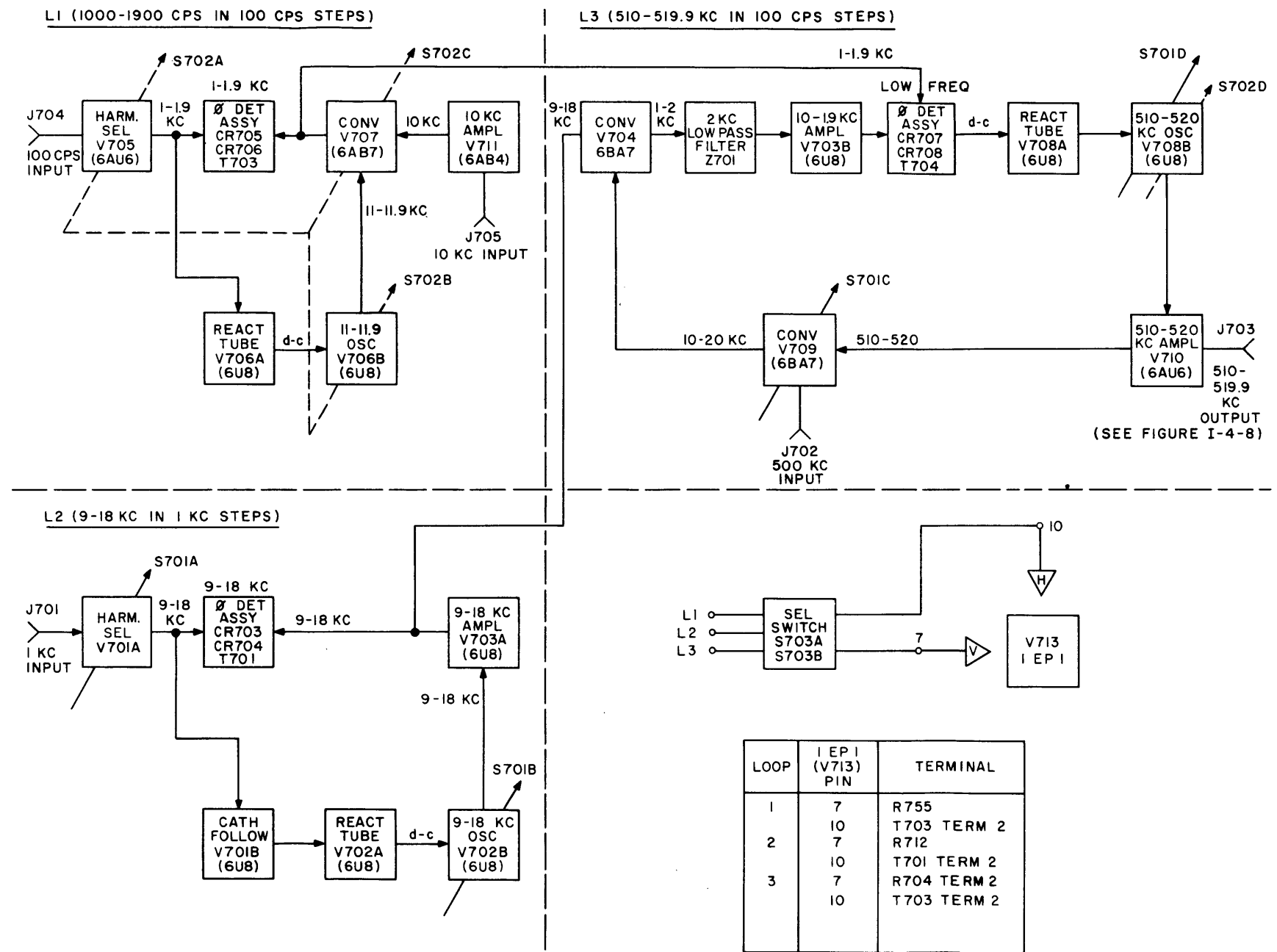

Figure I-4-9. Controlled Oscillator Model CLL-1 (Low Frequency Loop)

zener diodes to control heating, and other elements. The oscillator has a stability of one part in 10^8 per day. Parallel 1-mc transistor amplifiers Q601, Q602 amplify the oscillator's 1-mc output, which is passed on to 1-mc output terminals J601, J602, and J606.

The primary standard contains a phase detector network in order to compare the precision oscillator's output with either a primary standard, such as exists in Washington, or an external 1-mc source of voltage. The 25-0-25 microammeter M601 is used as a standard of frequency comparison. Schematic, figure III(C)-8-1, elaborates on the technical details indicated on block diagram, figure I-4-10.

I-4-8. DIVIDER CHAIN MODEL, CHL-1.

(See figure I-4-11.)

Refer to paragraph I-4-1.d in this part of the manual for the role played by phantastron delay circuits V104, V105, V107, and V108. V102 is a usual type 2:1 delay multivibrator.

The time constants on which the multivibrators largely depend for their frequency-dividing action are as follows:

Multivibrator	Time Constants
V102	C101, R103
V104	C109, R155, p/o R144
V105	C134, R156, p/o R124
V107	C120, R137, p/o R135
V108	C126, R148, p/o R147

The frequency-dividing action of the multivibrators also is a function of other parameters such as stray capacitances (important at their higher frequencies), cathode bias, triggering time, etc. At the lower frequencies, however, note that the product CR largely controls the frequency-dividing action of the multivibrators. In the following tabulation Ms indicates microseconds.

V108	1000: 100	Delay 10,000 Ms	C = 5000, R = 2.2	CR = 11,000 Ms
V107	10,000: 1000	Delay 1000 Ms	C = 560, R = 2.2	CR = 1230 Ms
V105	100,000: 10,000	Delay 100 Ms	C = 56, R = 2.2	CR = 123 Ms

Schematic, figure III(D)-8-1, elaborates on the technical details indicated on block diagram, figure I-4-11.

I-4-9. POWER SUPPLY, MODEL CPP-2.

(See figure I-2-12.)

The CPP-2 provides:

- a. +380 volt unregulated power supply.
- b. -400 volt unregulated power supply.
- c. +160 volt regulated power supply.
- d. +75 volt regulated power supply.
- e. -6 volt regulated power supply.
- f. 6.3 (AC) volt regulated power supply.

These supplies are routed as follows:

- a. Item a above, to CLL (J501, 8) and to CMO (J502, 8/9).
- b. Item b above, to CLL (J501, 5).
- c. Item c above, to CLL (J501, 16) to CMO (J502, 16) and to CHL (J503, 16).
- d. Item d above, to CLL (J501, 4).
- e. Item e above, to CHG (J503, 1) to CMO (J502, 1) and to CLL (J503, 9).
- f. Item f above, to CHG (J503, 13/15) to CMO (J503, 13/15) and to CLL (J503, 13/15).

T502 is a regulated 50/60 cycles transformer. Two secondary positions, one for 60-cycle supply and one for 50-cycle supply, are indicated. T502 is arranged for 115/230-volt supply. Schematic diagram, figure III(F)-8-1, elaborates on the technical details indicated on block diagram, figure I-4-12.

I-4-10. TONE INTELLIGENCE UNIT MODEL

TIS-3. (See figure I-4-13.)

As shown by functional block diagram, figure I-4-13, the TIS-3 accepts three types of d-c signals (FSK, CW, FAX) and converts them into audio frequency output signals for sideband transmission via an associated SBG unit that provides its RF sideband transmitter with the required RF intelligence.

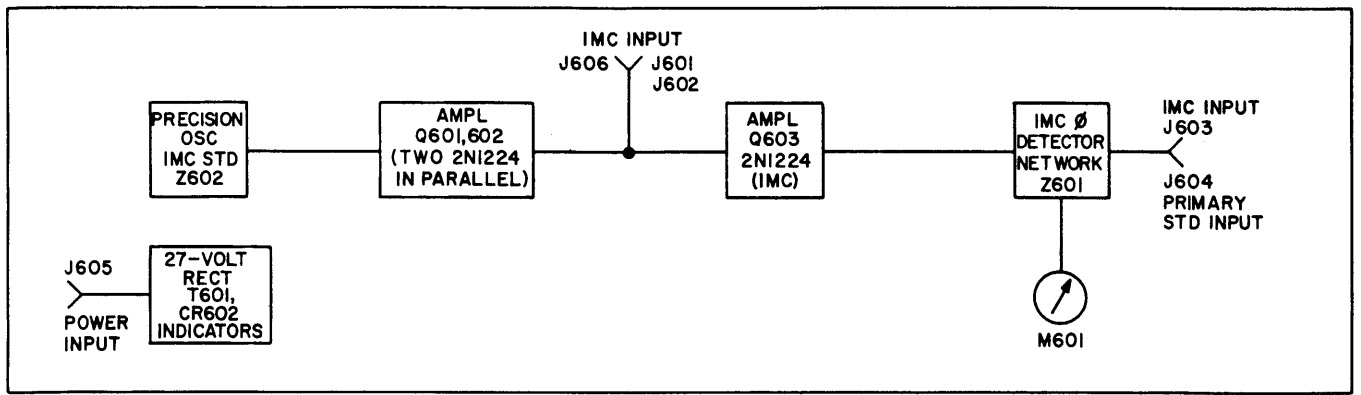

Figure I-4-10. Primary Standard Model CSS-1

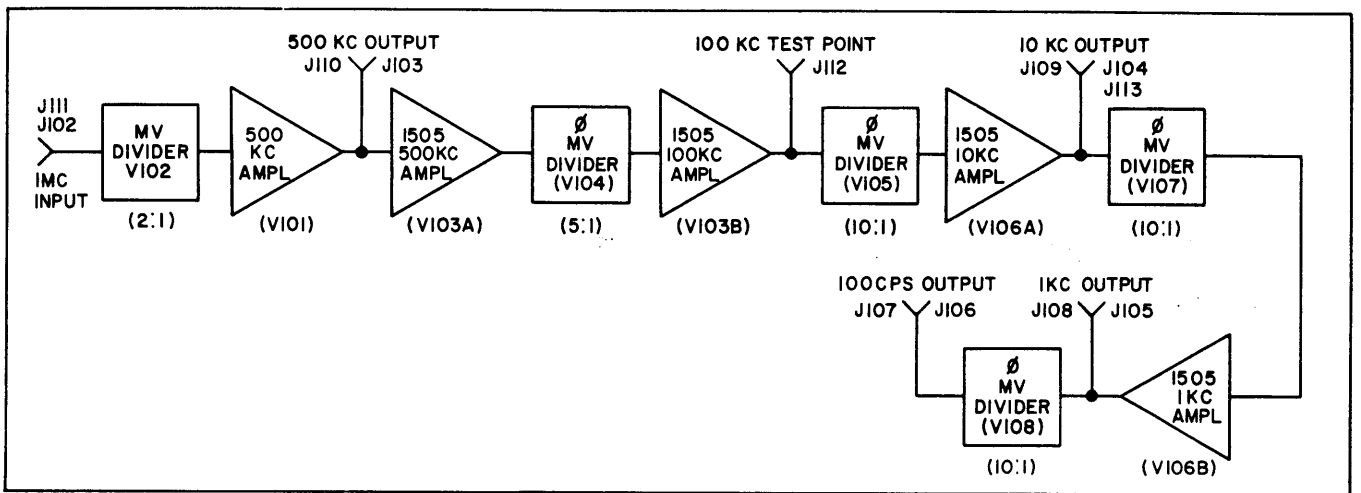
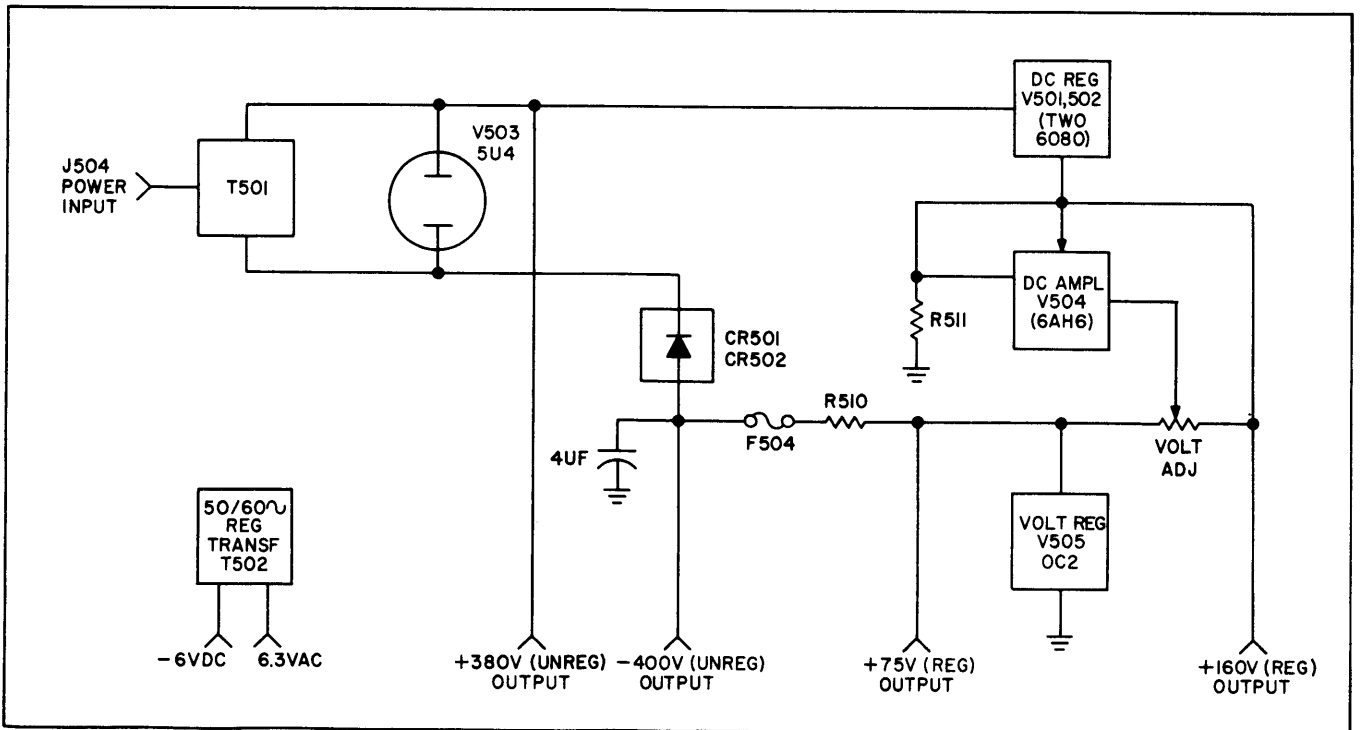

Figure I-4-11. Divider Chain Model CHL-1



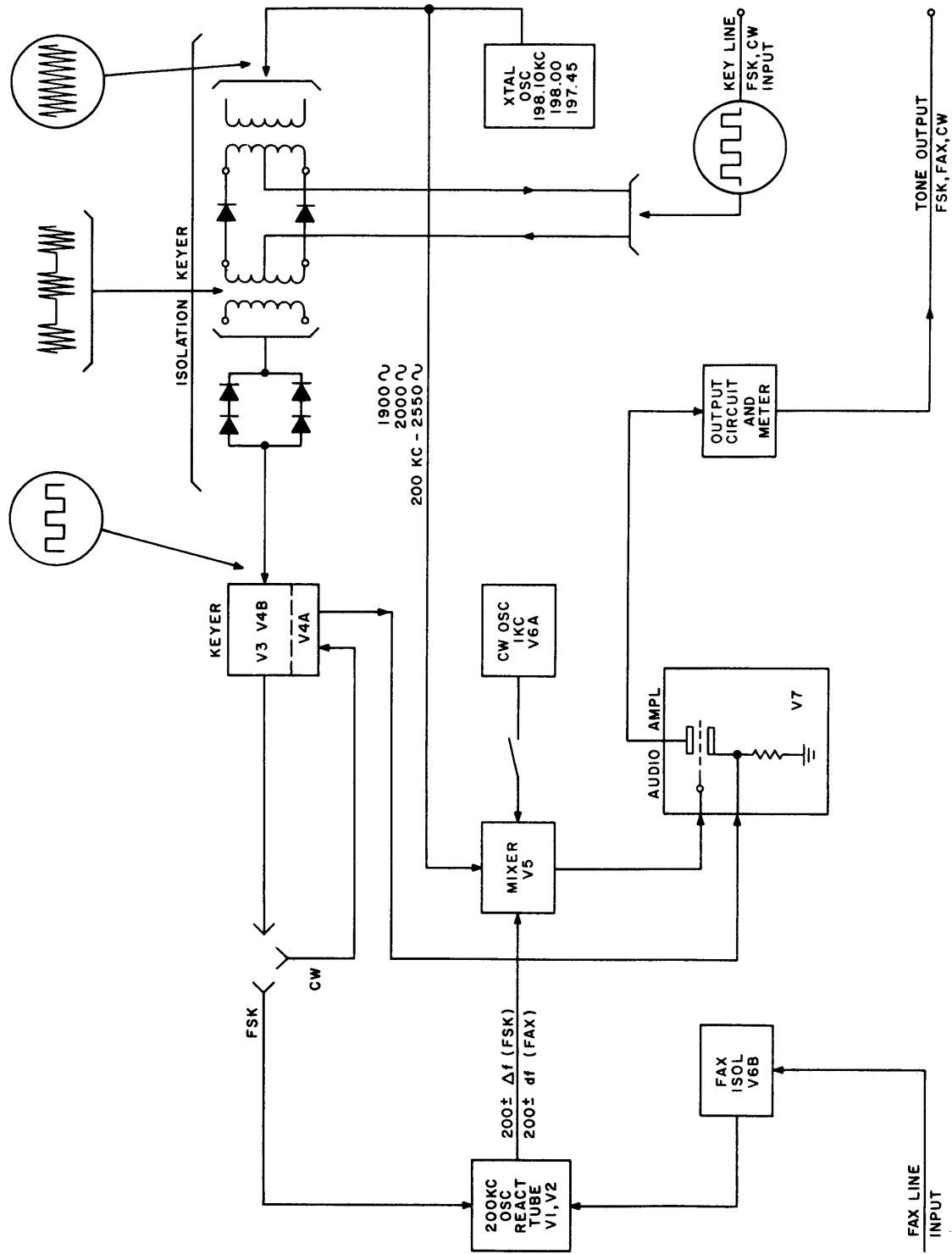

Figure I-4-13. Functional Block Diagram of Tone Intelligence System Model TIS-3
(A Component of SBG-1)

The key-line (FSK, CW) input is fed to an isolation keyer, which is also supplied by an 198.10- or 198.00- or 197.45-kc crystal oscillator output. The first stage of the isolation keyer has an output of spurts of the crystal oscillator's input, as controlled by the key-line signal (which makes a pair of diodes successively conducting and non-conducting). A second group of diodes rectifies the spurts of IF.

The keyer V3, V4B prepares the FSK signals to "frequency shift" the 200-kc oscillator which is equipped with a reactance tube. The FAX isolation tube V6B also frequency shifts V1, V2. The frequency-shifted 200 kc FSK, FAX signals proceed to mixer V5 where they are heterodyned with crystal oscillator's 198.10- or 198.00- or

197.45-kc output. The output of mixer V5 consists of frequency-shifted 1900-cps or 2000 cps or 2559-cps FSK, FAX signals which are amplified in audio amplifier V7 and then proceed to the associated SBG-1 CBE-1's audio input, channels 1 or 2.

On CW signals, keyer V3, V4B output is amplified by V4A to provide cathode bias to audio amplifier V7. Mixer V7's output consists of 1-kc spurts that again are routed to the associated SBG-1 CBE-1's audio input, channels 1 or 2.

For a stage-by-stage description of the TIS-3 see Part IV. The over-all schematic diagram is shown in figure IV-8-1.

SECTION 5

TROUBLE - SHOOTING

Generalized phases of trouble-shooting are outlined below; detailed phases of trouble-shooting appear in Parts II through IV as pertinent to specific equipment units.

I-5-1. GENERAL.

Trouble-shooting is the art of locating and diagnosing equipment troubles and maladjustments; the information necessary to remedy the equipment troubles and maladjustments is reserved for the various associated sections 6 of the manual under the heading "Maintenance".

Trouble-shooting tools may, for convenience, be divided into the following six categories:

- a. Accurate schematic diagrams.
- b. Tables of voltage and resistance; wave form data.
- c. Location data (photographs with callouts of the major electronic equipment elements).
- d. Trouble-shooting techniques.
- e. Trouble-shooting charts based on operating procedures.
- f. Trouble-shooting procedures based on circuit sectionalization.

Trouble-shooting techniques (item d) are about the same for all types of electronic equipment and are covered briefly in the following paragraphs.

I-5-2. TROUBLE-SHOOTING TECHNIQUES.

a. **GENERAL CONSIDERATIONS.** - When a piece of equipment has been working satisfactorily and suddenly fails, the cause of failure may be apparent either because of circum-

stances occurring at the time of failure or because of symptoms analogous to past failures. In this case, it is unnecessary to follow a lengthy and orderly course of trouble-shooting in order to localize and isolate the faulty part.

A second short cut in trouble-shooting is to ascertain that all tubes and fuses are in proper working order; also that the equipment receives proper supply voltages. Many times this will eliminate further investigation.

A third short cut is to examine the equipment, section by section, for burned out elements, charring, corrosion, arcing, excessive heat, dirt, dampness, etc. It is important to recognize that defective elements may have become defective due to their own weakness or to some contributing cause beyond their control.

Sometimes vibration will cause failure; for example with poorly soldered joints or when components normally isolated from others are shaken together. Such failures are more difficult to locate.

b. **TROUBLE-SHOOTING CHARTS BASED ON OPERATING PROCEDURES.** - The general purpose of these charts is to narrow the area of trouble to one or more sections of the equipment in order to minimize the labor of locating the source of trouble. These charts present a prescribed order "to turn on" the equipment, indicate what to expect as each step is taken, and give some clues as to possible "troubled areas" when some expectation is not realized.

c. **TABLES OF VOLTAGE AND RESISTANCE; WAVEFORM DATA.** - These tables give nominal values of voltage-to-frame and resistance-to-frame, generally at tube elements and sometimes at connectors and terminal board elements. During this process, accurate diagrams and location data are highly essential. Schematic diagrams of all equipments will be found in the various sections 8 of the manual.

A good oscilloscope is a first class trouble-shooting tool. It may be connected to a number of critical points along a circuit to detect extraneous or abnormal voltages, distorted waveforms, and other symptoms of trouble.

d. TROUBLE - SHOOTING PROCEDURES BASED ON CIRCUIT SECTIONALIZATION. - Equipments usually consist of a number of sub-assemblies or sections. It is frequently helpful

to treat these subassemblies or sections as independent entities. In so doing, however, they must be properly powered. Observations may then be made with VTVMs, CROs, or other test equipment at selected points under given types and magnitudes of injection voltages. Again, the subassemblies or sections may be examined for rated performance, according to specifications, for the presence of extraneous grounds, for opens, or unusual voltages.

SECTION 6 MAINTENANCE

Generalized phases of maintenance are outlined below; detailed phases of maintenance appear in Parts II through IV as pertinent to specific equipment units.

I-6-1. GENERAL.

Synthesized GPT-10K and GPT-40K exciter frames contain assemblies of many electrical and mechanical parts which may be maintained adequately by conventional preventive and corrective maintenance techniques as outlined in the following paragraphs. Long life and continual operation of moving parts require especially good maintenance. When a component fails in a highly precise frequency-sensitive assembly, it is generally more practical to replace the entire assembly than to attempt to repair it. Such assemblies may then be returned to the factory for repair and adjustment. The same is true of complicated mechanical assemblies. Fabrication of parts peculiar without suitable tools makes the replacement of the entire assembly more practical than disassembly, fabrication, and reassembly. Pieces of GPT-10 and GPT-40K exciter frame equipment, that fall into this category are band and load switches, blowers, contactors, relays, etc.

I-6-2. OPERATOR'S MAINTENANCE.

Operator's maintenance consists in not only maintaining optimum equipment performance at all times but also keeping a detailed record of the equipment performance as well as a log of events and happenings, including climatic conditions, pertinent to equipment operation. Such records are useful in spotting gradual equipment degradation and when more general remedial measures are necessary.

I-6-3. PREVENTIVE MAINTENANCE.

Preventive maintenance is maintenance that detects and corrects trouble producing items before they become serious enough to affect

equipment operation adversely. Some trouble producing items are dirt and grime, contact erosion, improper contact pressure, lack of proper lubrication, improper relay adjustment, dirty air filter, overheating, unstable power supplies, vacuum tubes with poor emission, loose parts (due to vibration), etc.

It may appear contradictory to state that good preventive maintenance means that one should not constantly poke around and tinker with an equipment that is performing excellently. Overzealous maintenance can readily cause more, rather than less, potential trouble. Good preventive maintenance requires constant vigilance and good judgment of when, what, and how to apply remedial measures.

a. ONCE EACH SHIFT DURING AN "ON THE AIR" PERIOD. - Check the operator's performance record for irregularities and possible sources of future trouble. Make minor adjustments of tuning controls to verify proper tuning. Observe all electrical quantities measurable with built-in meter and compare observations with established standards for irregularities. Observe indicator lights; and rectifier tubes for abnormal color and signs of internal flashing.

b. DAILY DURING AN "OFF THE AIR" PERIOD. - Visually and manually inspect parts for overheating and damage. Inspect sliding or moving coil contacts. Feel blower motor for overheating and observe rotating parts for wear. Note deposits of dust and dirt. Inspect conditions of relay contacts. Check operation of all interlocks.

c. MONTHLY DURING "OFF THE AIR" PERIODS. - Recondition rotary and switch contacts as necessary. Use crocus cloth and trichloroethylene or ethylenedichloride for cleaning. Inspect and rid the equipment of dust and dirt. Check the condition of the air filter; replace or clean dirty filters. Inspect the equipment for loose soldered connections or screws especially in those cases experiencing appreciable vibration in service. Note the condition of

gear trains; those showing signs of becoming dry should be lubricated with a drop of two of any high quality, light machine lubricant. Check the condition of all tubes.

I-6-4. CORRECTIVE MAINTENANCE.

Corrective maintenance is an aftermath of trouble-shooting as discussed in section 5, or preventive maintenance as discussed in the preceding paragraph. With the exception of those

cases when components suddenly fail for no apparent good reason or under extenuating circumstances, an intelligent program of preventive maintenance should produce minimum equipment outage.

After a defective part has been localized and isolated by the trouble-shooting techniques presented in various sections 5 of the manual, replacement generally presents no major problem particularly in the case of failure of non-complex electrical and mechanical components.