

UNCLASSIFIED

TECHNICAL MANUAL

for

Independent AGC Receiving System

Model MSG-3I



THE TECHNICAL MATERIEL CORPORATION
MAMARONECK, N.Y. OTTAWA, ONTARIO

COPYRIGHT 1967
THE TECHNICAL MATERIEL CORPORATION

TABLE OF CONTENTS

<u>Paragraph</u>		<u>Page</u>
<u>SECTION 1-GENERAL INFORMATION</u>		
1-1	Functional Description	1-1
1-2	Description of units	1-1
1-3	Technical Specifications	1-2
<u>SECTION 2-INSTALLATION</u>		
2-1	Initial Inspection	2-1
2-2	Initial Installation	2-1
2-3	Electrical Installation	2-1
<u>SECTION 3-OPERATOR'S SECTION</u>		
3-1	General	3-1
3-2	Operator's Instructions	3-1
<u>SECTION 4-PRINCIPLES OF OPERATION</u>		
4-1	Introduction	4-1
4-2	Block Diagram Analysis	4-1
<u>SECTION 5-MAINTENANCE</u>		
5-1	Preventive Maintenance	5-1
5-2	Troubleshooting	5-2
5-3	Repair and Replacement	5-4
5-4	Operational Checks	5-4
<u>SECTION 6-PARTS LIST</u>		
6-1	Introduction	6-1

LIST OF ILLUSTRATIONS

<u>Figure</u>		<u>Page</u>
<u>SECTION 1-GENERAL INFORMATION</u>		
1-1	Independent AGC Receiving System, Model MSG-3I	1-0
<u>SECTION 2-INSTALLATION</u>		
2-1	Output Connections	2-2
2-2	Interconnecting Cable Diagram, MSG-3I	2-3/2-4
<u>SECTION 3-OPERATOR'S SECTION</u>		
3-1	Controls and Indicators	3-6
<u>SECTION 4-PRINCIPLES OF OPERATION</u>		
4-1	Block Diagram, MSG-3I	4-3/4-4
<u>SECTION 5-MAINTENANCE</u>		
5-1	Fuse Locations	5-4

LIST OF TABLES

<u>Table</u>		<u>Page</u>
<u>SECTION 1-GENERAL INFORMATION</u>		
1-1	Equipment Supplied	1-2
<u>SECTION 3-OPERATOR'S SECTION</u>		
3-1	Controls and Functions	3-2
<u>SECTION 5-MAINTENANCE</u>		
5-1	Fuse Functions	5-3
5-2	Test Equipment Required	5-6

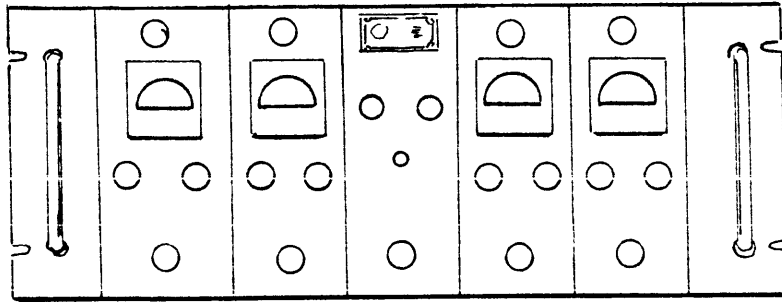

MULTIPLE SIDEBAND
ADAPTER, MSA-1

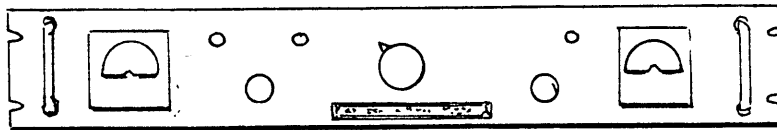

AUTOMATIC FREQUENCY
CONTROL, AFC-2A

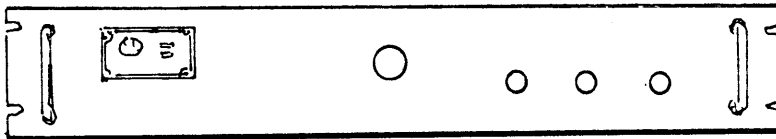

MUX CARRIER
GENERATOR, MCG-2I



POWER SUPPLY,
MPS-1

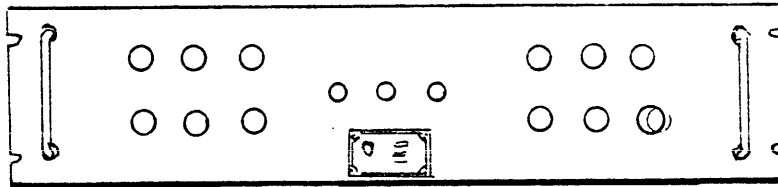

POWER SUPPLY,
HFP-1A

Figure 1-1. Independent AGC Receiving System. Model MSG-3I

SECTION 1

GENERAL INFORMATION

1-1. FUNCTIONAL DESCRIPTION

Independent AGC Receiving System, Model MSG-3I (figure 1-1) is a four-channel, single sideband suppressed multiple carrier demultiplexer.

The MSG is used to accept a 455 kc composite i-f input from an associated receiver, and provide 4-channel demultiplexed audio outputs.

1-2. DESCRIPTION OF UNITS

a. MULTIPLE SIDEBAND ADAPTER, MSA-1 - The MSA is used to accept and demultiplex the 455 kc composite i-f input from an associated receiver and provide four discrete audio outputs.

b. MULTIPLEX CARRIER GENERATOR, MCG-2I - The MCG is used to generate the 705 kc i-f translation frequency along with 250 kc, 256.25 kc and 243.75 kc demultiplexing signals. The 250 kc signal is used to demultiplex the inboard carriers in the MSA, while the two sideband carriers are used to demultiplex the outboard carriers in the same unit.

c. AUTOMATIC FREQUENCY CONTROL, AFC-2A - The AFC is used in the i-f section of a receiver system to compensate for a combined frequency drift in the receiver and distant transmitter. The AFC functions to maintain the audio output error from the receiver product detector to within ± 1 kc.

d. POWER SUPPLY, MPS-1 - The MPS is used to provide the regulated 25 volts d-c used in the MCG sideband crystal standard.

e. POWER SUPPLY, HFP-1A - The HFP is used to provide regulated B+ and bias voltages, along with filament voltages for the MSA.

1-3. TECHNICAL SPECIFICATIONS

INPUT FREQUENCY: 455 kc

INPUT IMPEDANCE: 50 ohms

NUMBER OF CHANNELS: Four (A1, A2, B1 and B2)

OUTPUT: Up to 10 milliwatts from each channel for balanced 600-ohm load.

MONITORING: A monitoring circuit is provided to permit head-phone monitoring of any audio channel without affecting the audio output (line) circuits.

SIDEBAND REJECTION: Undesired sideband removed more than 250 cycles from the carrier suppressed a minimum of 60 db.

DESTORTION: Intermodulation products at least 50 db below full output with two signals in the desired channel.

POWER REQUIREMENTS: 115/230 volts a-c, 48/62 cps, single phase power.

Table 1-1. Equipment Supplied

NOMENCLATURE	QTY	DIMENSIONS		
		HEIGHT	WIDTH	DEPTH
Multiple Sideband Adapter, Model MSA-1.	1	7"	19"	17"
Multiplex Carrier Generator, Model MCG-2I.	1	3-1/2"	19"	12"
Power Supply, Model MPS-1.	1	3-1/2"	19"	9-1/4"
Power Supply, Model HFP-2A.	1	5-1/4"	19"	18"
Automatic Frequency Control, Model AFC-2A.	1	3-1/2"	19"	14-3/4"
Attenuator assembly, A4288-1.	1	3-1/2"	13"	4"
Filter Assembly, A4298-2.	1	2-1/2"	4-1/2"	1-1/4"

SECTION 2

INSTALLATION

2-1. INITIAL INSPECTION

Each modular unit comprising the MSG system has been thoroughly checked and tested at the factory before shipment. Upon arrival of the equipment at the operating site, inspect each packing case and its' contents immediately for possible damage. Unpack the equipment carefully, and inspect all packing material for parts which may have been shipped as loose items.

With respect to damage to the equipment for which the carrier is liable, The Technical Materiel Corporation will assist in describing methods of repair and the furnishing of replacement parts.

2-2. INITIAL INSTALLATION

All of the major modular units comprising the MSG system are equipped with standard width 19-inch front panels. These units are designed to be mounted in any standard width equipment rack or cabinet. See figure 2-1 for electrical interconnections. Refer to the individual modular unit technical manuals for detailed connection and installation procedures.

2-3. ELECTRICAL INSTALLATION

All modular units comprising the MSG are factory wired to operate from a line voltage input of 115 volts, 50/60 cycles. Operation from 230 volts line voltage may be achieved by simple wiring changes shown in the individual modular unit technical manuals.

CAUTION

If 230 volts a-c operation is used, all line fuses must be reduced to one half their rated current values to assure adequate circuit protection. Regulated and high voltage fuses remain the same with either line voltage.

Refer to the individual modular unit technical manuals for details.

Input power to the MSG is applied at the HFP input connector J8001. Connect the

supplied cable W8514 (CA696-1) to a suitable 115 volts a-c, 50/60 cycle power source, with P8001 plugged into J8001 of the HFP.

Inter-unit cabling is achieved as shown in figure 2-2. Figure 2-1 illustrates the filter assembly A4298-2 connections.

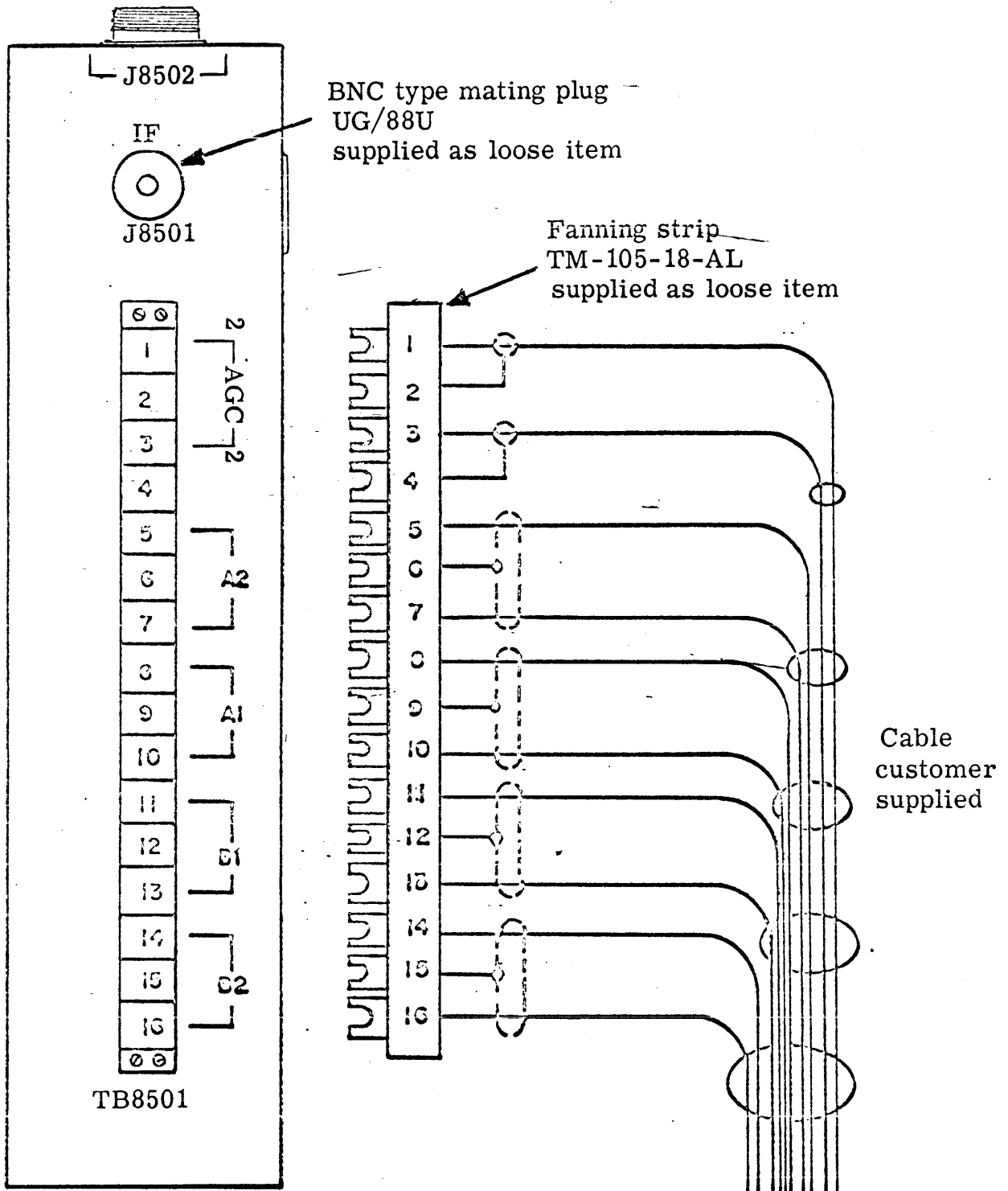
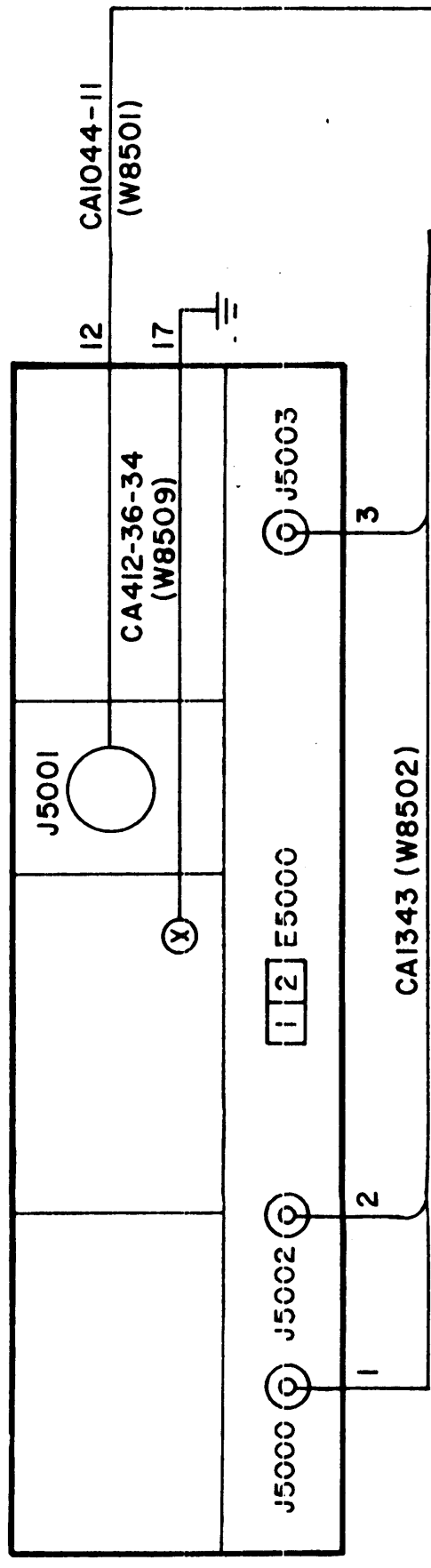

Figure 2-1. Output Connections

REDUCE TO 10-1/2

THE TECHNICAL MATERIEL CORP.
 MAMARONECK, NEW YORK
 MODEL MSG-3I CM380-Ø

AFC-2A



MSA-1

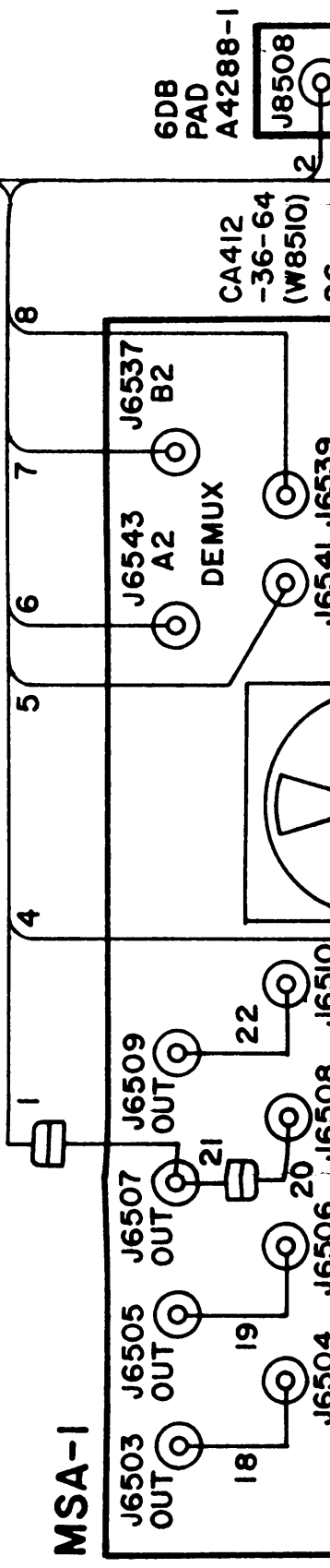

CA1149-1 (W8507)

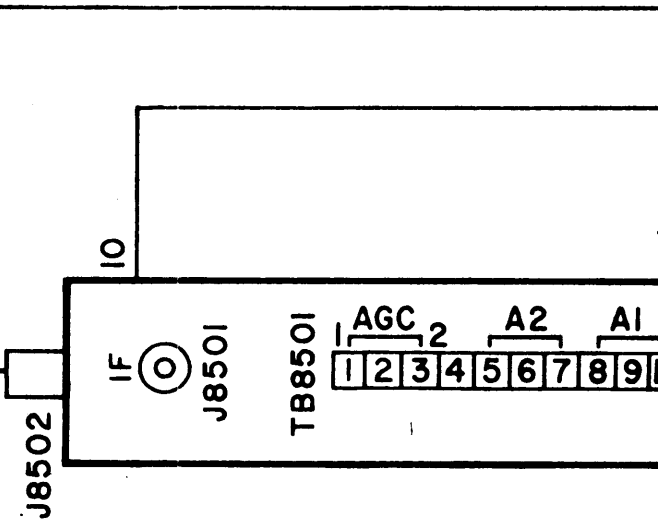

D

C

B

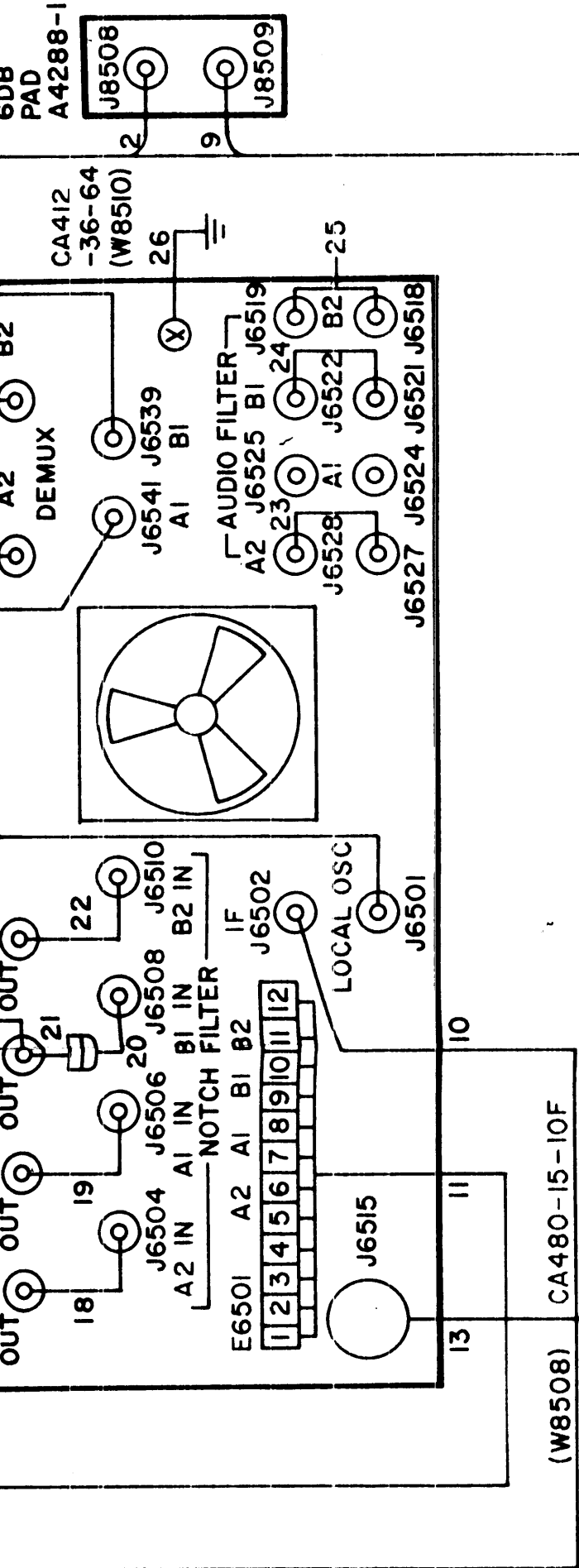
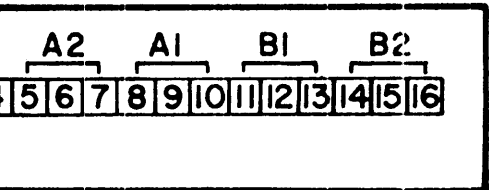

5

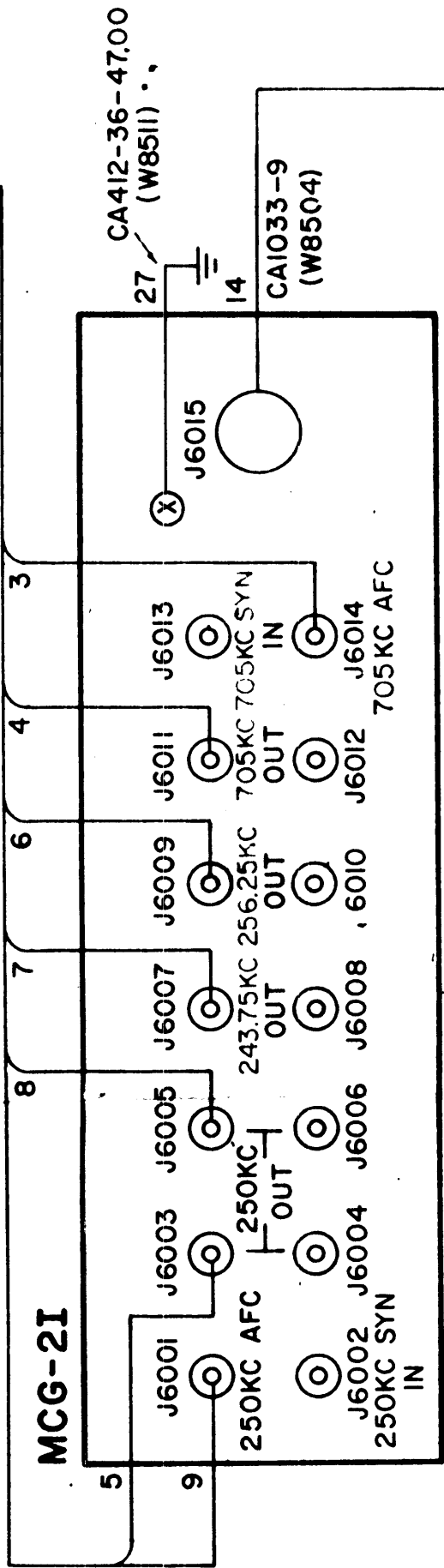

4

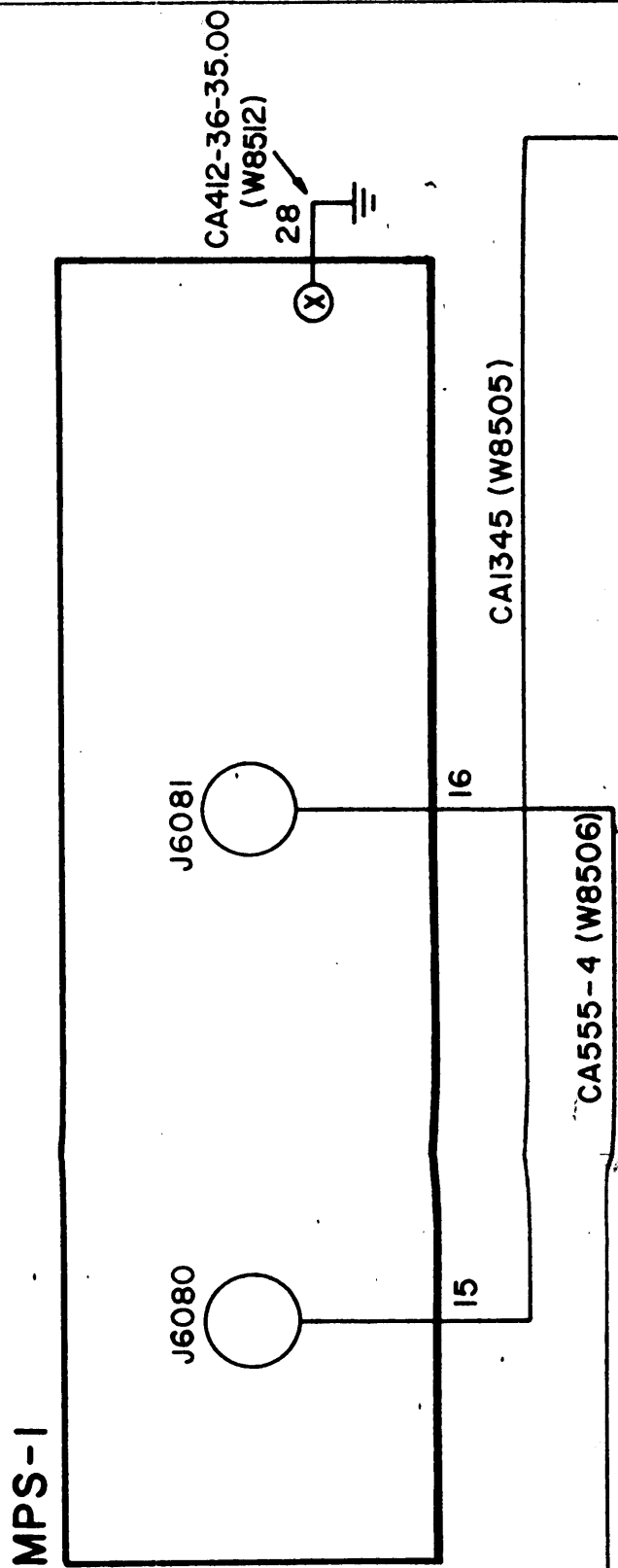

FUSE CHART	
NIT	SYMBOL NO. IIS 50/60
FP-1	F8001 15A
	F8002 15A
	F8003 4A
	F8004 4A
	F8005 2A
	F8006 1/10A
	F8007 3/4A
	F8008 3/4A
	F8009 4A
	F8010 .125A
FP-1	F8011 15A
	F8012 .375A
	F8013 10A
	F8014 .125A
	F8015 5A
	F8016 .250A
	F8017 8A
	F8018 .250A
	F8019 .375A
	F8020 10A
PS-1	F6080 .250A

REVISIONS							
ZONE	LTR	DESCRIPTION	DATE	E. M. N. NO.	DRAFT	CHKD	APPD
	X	EXPERIMENTAL RELEASE	5.17.67	--	W.H.W.		
	X	REVISED # 4					
	X	ORIGINAL RELEASE FOR PRODUCTION					

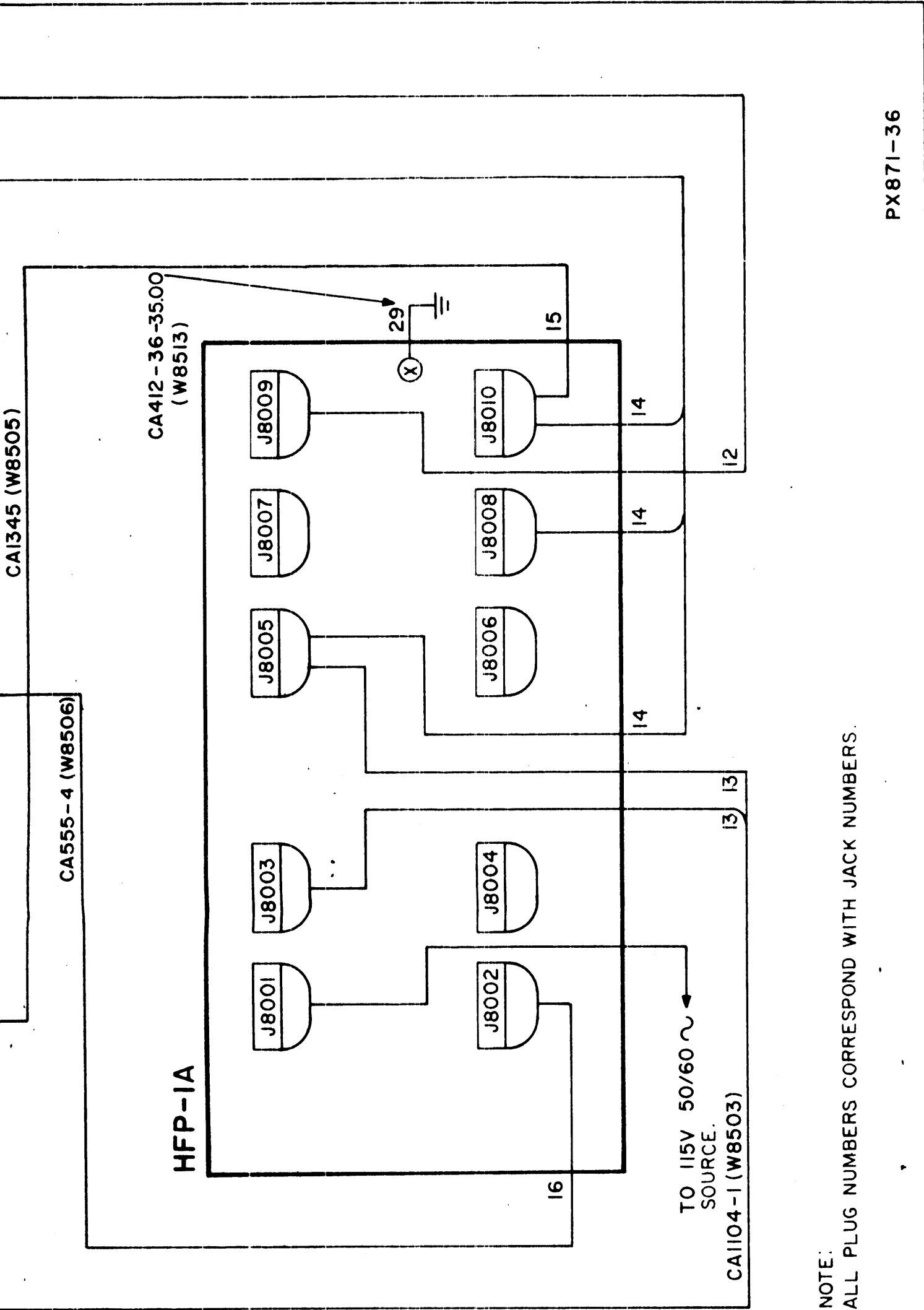

NOTE:
ALL PLUG NUMBERS CORRESPOND WITH JACK NUMBERS.

D

C

00

0831X30

2

A B C

REDUCE TO 10-1/2

THE TECHNICAL MATERIEL CORP.
 MAMARONECK, NEW YORK
 MODEL MSG-3I CM380-Ø

AFC-2A

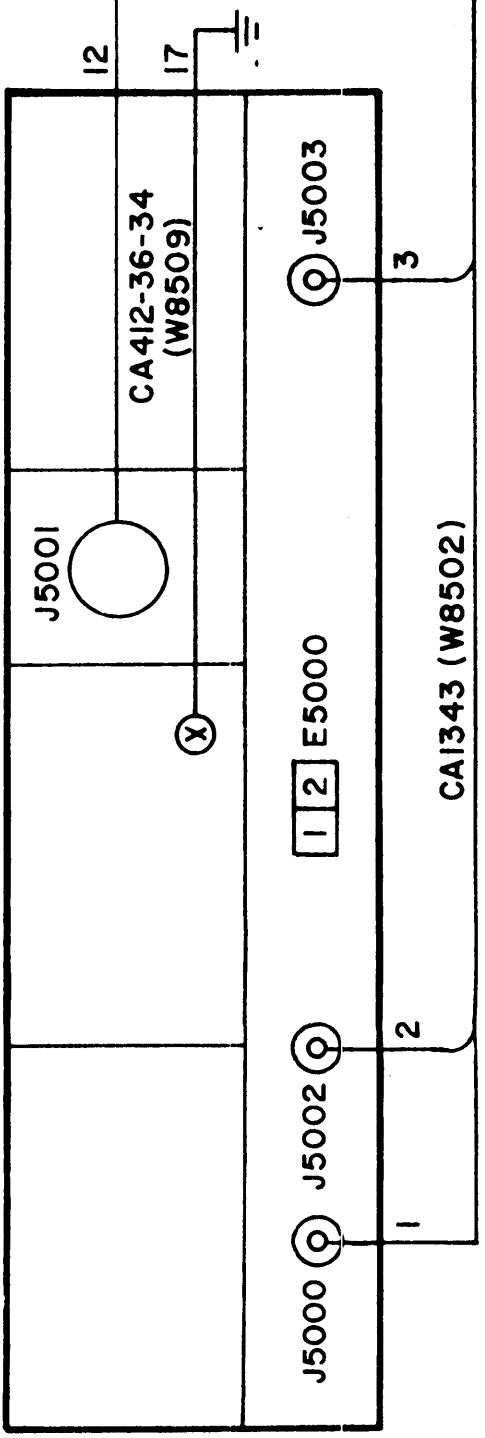

CA1149-1 (W8507)

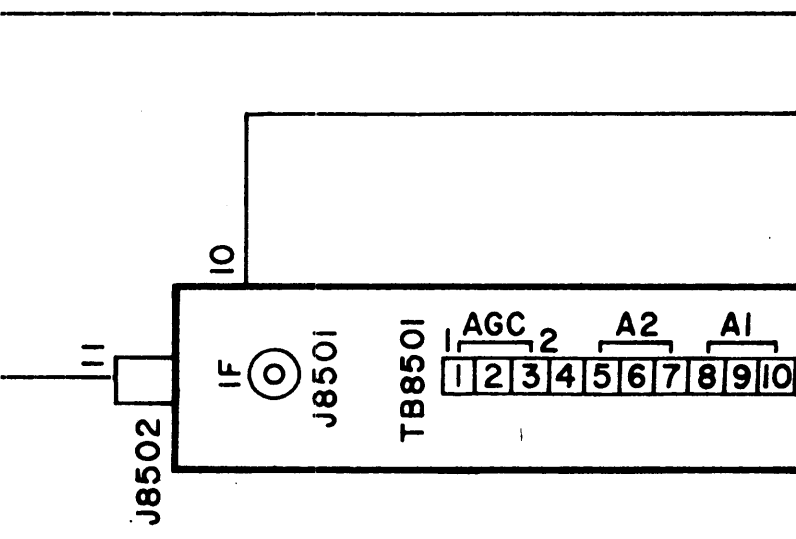

MSA-1

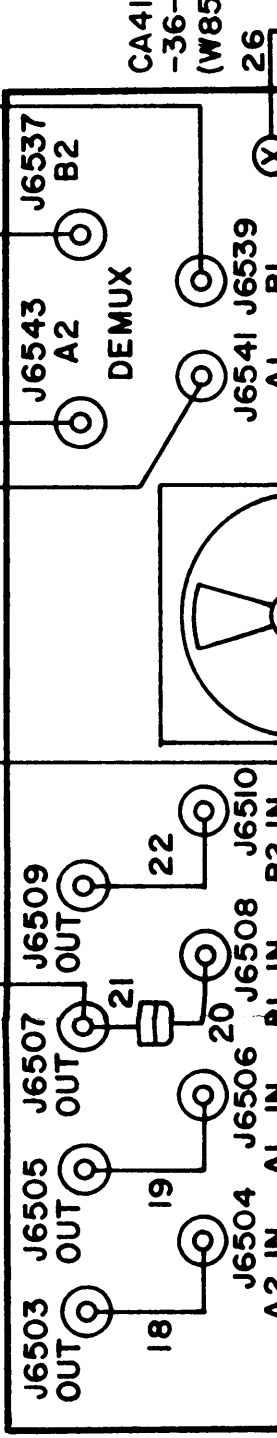

NOTE
 IF LAMINATING IS DESIRED
 REFER TO PX871-36 FOR DETAIL

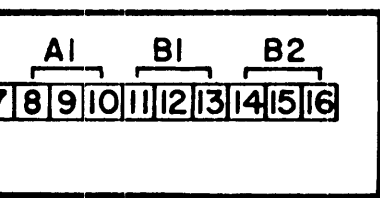
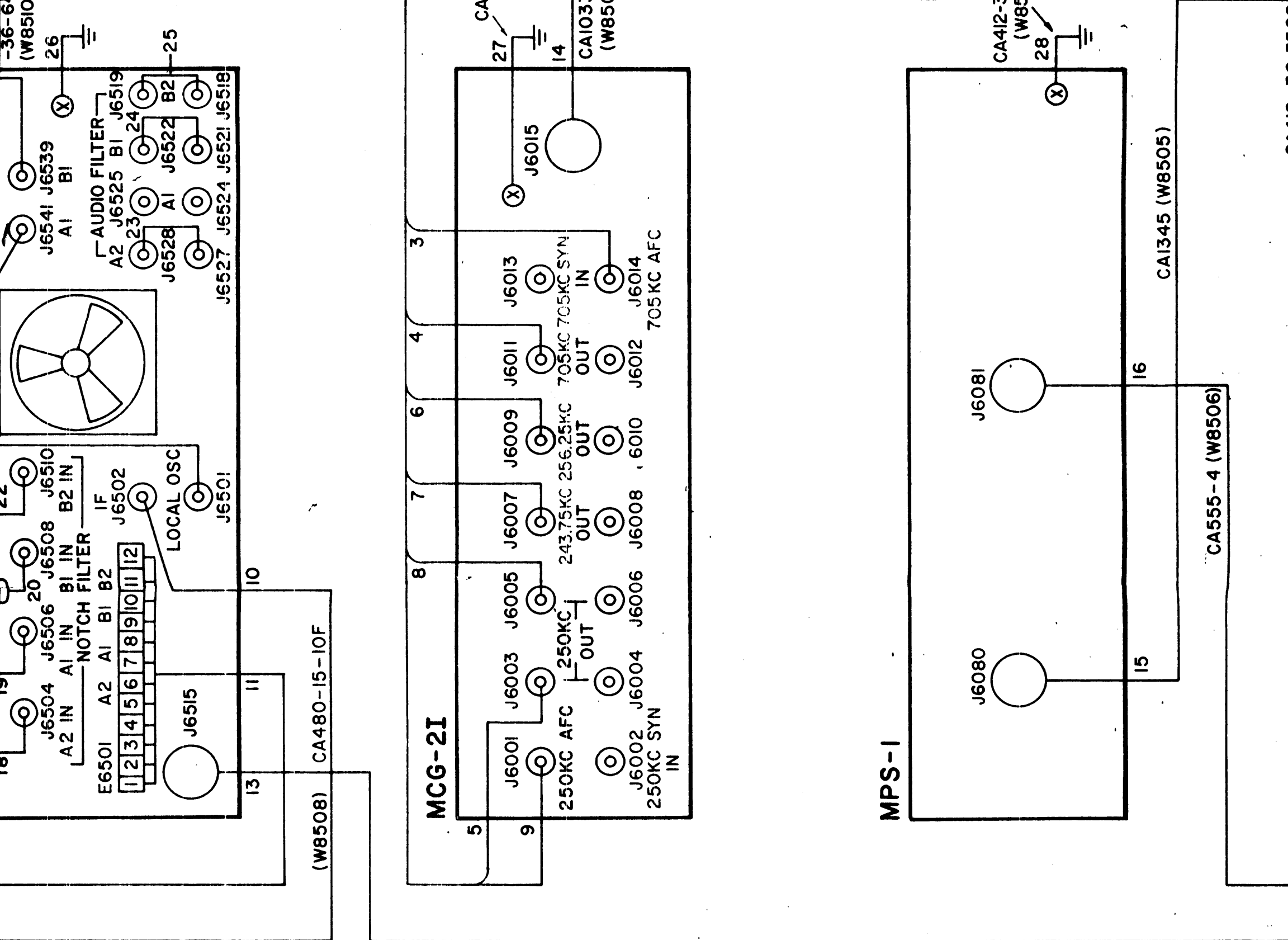

FUSE CHART	
UNIT	SYMBOL NO. I15 50/60
HFP-1	F8001 15A
	F8002 15A
	F8003 4A
	F8004 4A
	F8005 2A
	F8006 1/10A
	F8007 3/4A
	F8008 3/4A
	F8009 4A
	F8010 .125A
HFP-1	F8011 15A
	F8012 .375A
	F8013 10A
	F8014 .125A
	F8015 5A
	F8016 .250A
	F8017 8A
	F8018 .250A
	F8019 .375A
	F8020 10A
MPS-1	F6080 .250A

D
DETAILS.

MSG-3I		
QTY / UNIT*	MODEL USED ON	ASS'Y NO.
APPLICATION		
CODE		

NOTICE TO PERSONS RECEIVING THIS DRAWING
 THE TECHNICAL MATERIEL CORPORATION claims proprietary right in the material disclosed hereon. This drawing is issued in confidence for engineering information only and may not be reproduced or used to manufacture anything shown hereon without permission from THE TECHNICAL MATERIEL CORPORATION to the user. This drawing is loaned for mutual assistance and is subject to recall at any time.

UNL
DIM
AND IN

DEC
.X
.XX
.XXX

MATER

FINISH

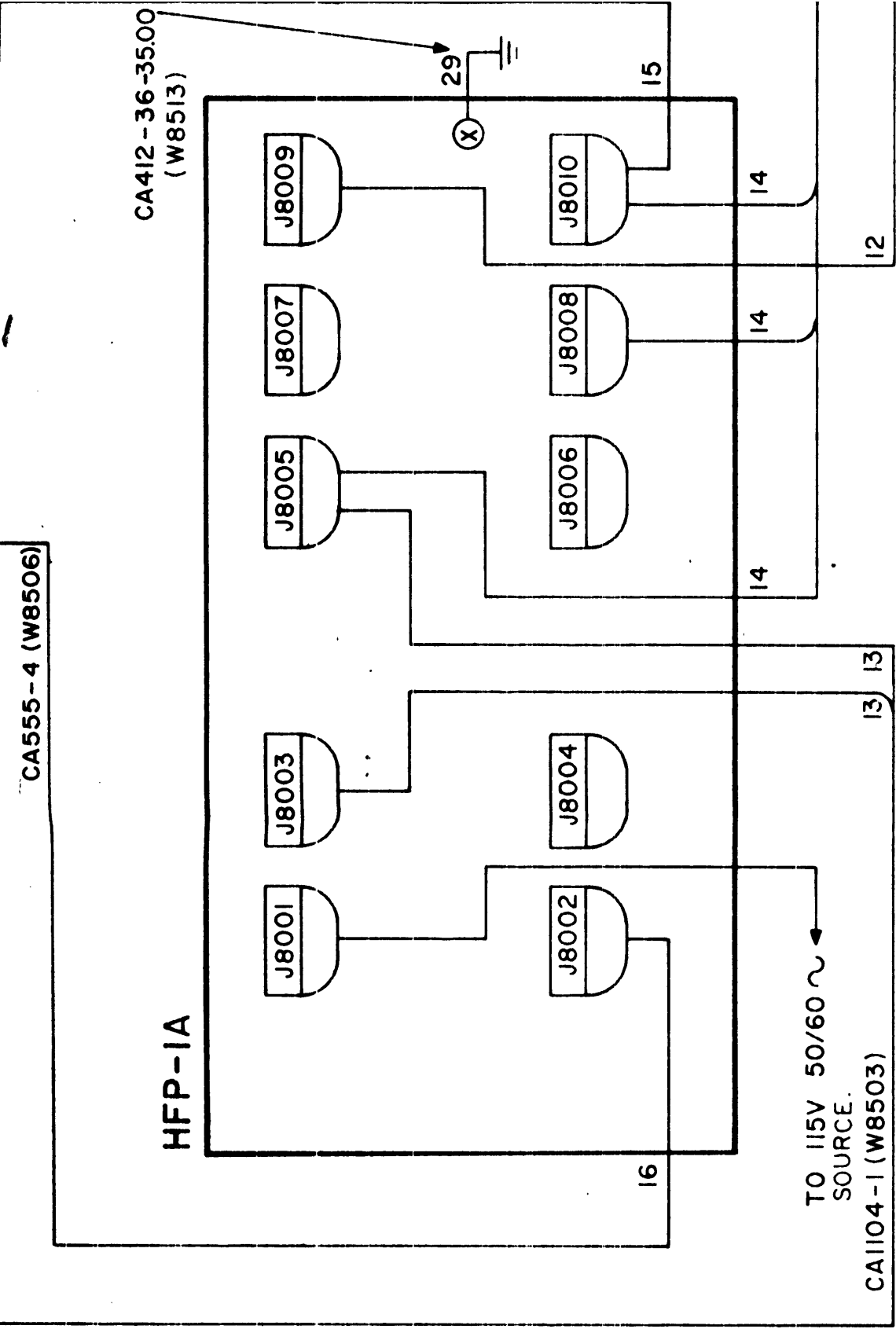

NOTE:
ALL PLUG NUMBERS CORRESPOND WITH JACK NUMBERS.

CKI380

QTY REQ.	ITEM	PART NO.	DESCRIPTION	SYMBOL
M. STURMER				
LIST OF MATERIAL				
UNLESS OTHERWISE SPECIFIED DIMENSIONS ARE IN INCHES AND INCLUDE CHEMICALLY APPLIED OR PLATED FINISHES		FINAL APPROVAL	DATE	THE TECHNICAL MATERIEL CORP. MAMARONECK, NEW YORK DIAGRAM, WIRING (MSG-3I)
TOLERANCES ON		MECH DES	DATE	
DECIMALS	FRACTIONS	ELECT DES	DATE	
.X ± .05	± 1/64	CHECKED	DATE	
.XX ± .01	ANGLES	DRAWN	DATE	
.XXX ± .005	± 0°-30'	W. WILLIAMS	5.17.67	
MATERIAL		SIZE	CODE IDENT. NO.	DWG NO.
FINISH		D	82679	CKI380
		SCALE	Figure 2-2. Interconnecting Cable Diagram, MSG-3I	
			ISSUE	
			OF 2-3/2-4	

3

2

1

A

SECTION 3

OPERATOR'S SECTION

3-1. GENERAL

The MSG is used in conjunction with an associated receiver, accepting the receiver 455 kc composite i-f signal, and demultiplexing it to an output of four discrete audio channels. For proper operation, therefore, the associated receiver must be properly tuned, and the MSG controls be properly set.

3-2. OPERATING INSTRUCTIONS

Haphazard operation or improper setting of the MSG controls will result in poor reception. For this reason, the operator should first familiarize himself with all operating controls and indicators on the MSG.

Table 3-1, used in conjunction with figure 3-1, lists the controls and indicators, and their associated functions, of the various units comprising the MSG. Table 3-1, enhanced by the operating procedures listed in the modular unit technical manuals, will enable an operator to understand the use and operation of the MSG controls.

Table 3-1. Controls and Functions

UNIT	SERIEL DESIGNATION (Figure 3-1)	PANEL DESIGNATION	FUNCTION
MSA-1	1 2 3 4	CHANNEL A1 CHANNEL A2 CHANNEL B1 CHANNEL B2 (lamps)	Lamp lights to indicate that associated channel is being used.
	5,6,10,11	CHANNEL A1 CHANNEL A2 CHANNEL B1 CHANNEL B2 (meters)	Meters indicate db level of associated channel audio output signal as set by LINE LEVEL control.
	7	MONITOR LEVEL (control)	Controls the amplitude of audio signal available at MONITOR jack.
	8	MONITOR (jack)	Permits headset monitoring of any one of four audio output channels as selected by MONITOR SELECT control.
	9	MONITOR SELECT (switch)	Selects any one of four channel (A1,A2,B1 or B2) audio outputs to be monitored.
	12	AGC DECAY (control)	Adjusts the decay time of the channel age signal.
	13	SQUELCH ADJUST (control)	Selects input signal level required enable the A1 channel audio amplifier. Normally adjusted when the channel is inactive by setting the control to a point where the CHANNEL A1 indicator lamp goes off.
	14	LINE Level (control)	Adjusts the level of the channel audio output level as indicated by CHANNEL A1 panel meter.
	15	AGC DECAY (control)	Same as item 12, channel A2.
	16	SQUELCH ADJUST (control)	Same as item 13, channel A2.
17	LINE LEVEL (control)	Same as item 14, channel A2.	

Table 3-1. Controls and Functions (Con't)

UNIT	SERIAL DESIGNATION (Figure 3-1)	PANEL DESIGNATION	FUNCTION
MSA-1 (Con't)	18	STANDBY-ON (power switch)	ON position applies operating power from external power supply to MSA. STANDBY position removes operating power from MSA.
	19	AGC DECAY (control)	Same as item 12, channel B1.
	20	SQUELCH ADJUST (control)	Same as item 13, channel B1.
	21	LINE LEVEL (control)	Same as item 14, channel B1.
	22	AGC DECAY (control)	Same as item 12, channel B2.
	23	SQUELCH ADJUST (control)	Same as item 13, channel B2
	24	LINE LEVEL	Same as item 14, channel B2.
AFC-2A	25	DRIFT (meter)	Indicates total drift of receiver i-f carrier. Center scale reading is zero drift. The dial is color coded as follows: <u>COLOR</u> <u>DRIFT (Approx)</u> GREEN: 500 cps YELLOW: 500 cps-1 kc RED: 1 kc +
	26	ALARM (lamp)	Light indicates carrier drift has exceeded approx. \pm 750 cps off center.
	27	SENSITIVITY (control)	Controls gain of carrier amplifier stage; may be backed-off to eliminate noise.
	28	RESET (switch)	RE-centers AFC oscillators when operator is required to tune to another station or re-synchronize due to a drifted signal.
	29	TUNING-KCS (control)	Tunes AFC unit's converter injection oscillator to enable operator to synchronize to the receiver signal.
	30	CARRIER SELECTOR (switch)	Normally operated in OSC position; product detector oscillator supplies

Table 3-1. Controls and Functions (Con't)

UNIT	SERIEL DESIGNATION (Figure 3-1)	PANEL DESIGNATION	FUNCTION
AFC-2A (Con't)	30 (Con't)		<p>a corrected 250 kc injection frequency to the receiver product detector. In OSC position, unit responds to correct for carrier drift at the speed rated (10 cps/second max.); the 250 kc injection frequency will be in phase with carrier input <u>within</u> 1 cycle (or 360°).</p> <p>In cases where phase is of primary importance however, it may be elected to set switch at RCC position (re-constructed carrier). This effectively strips the 250 kc carrier of its sidebands, amplifies it, and feeds it back into the receiver product detector as the injection frequency.</p>
	31	FADE (lamp)	Light indicates deep fade of received carrier.
	32	LEVEL (meter)	Indicates level of carrier.
MCG-21	33	Selector switch (3-position)	<p>When set at INT, connects internally generated 250 kc and 705 kc signals to their respective output jacks.</p> <p>When set at AFC, connects drift-compensated 250 kc and 705 kc from associated AFC unit to their respective output jacks, routes B+ voltage to associated AFC unit.</p> <p>When set at SYN, connects stabilized 250 kc and 705 kc signals from associated synthesizer to their respective output jacks.</p>
	34	OVENS, HR6001 (lamp)	Indicates periods of oven heating for the 100.00 kc crystal. Goes on when the oven temperature drops below 75°C; goes off when oven temperature rises above 75°C.
	35	OVENS, HR6002	Same as item 34, except lamp indicates 705 kc crystal.
	36	OVENS, HR6003 (lamp)	Same as item 34, except lamp indicates oven temperature of the 250 kc

Table 3-1. Controls and Functions (Con't)

UNIT	SERIEL DESIGNATION (Figure 3-1)	PANEL DESIGNATION	FUNCTION
MCG-21 (Con't)	36 (Con't)		crystal.
MPS-1	37	POWER (lamp)	Lights when power is applied to unit.
HFP-1A	38	STANDBY (lamp)	Indicates HFP is in STANDBY condition; HFP is sending power to oscillator ovens and unit frequency standards.
	39	TIME DELAY (lamp)	Indicates HFP is going through time delay stage between standby and operate conditions.
	40	OPERATE (lamp)	Indicates HFP is in OPERATE condition; sending power to all system connected units.
		MAIN POWER (switch on rear panel)	STANDBY position sends power to oscillator ovens and unit frequency standards. OFF position disconnects main line voltage input to HFP.

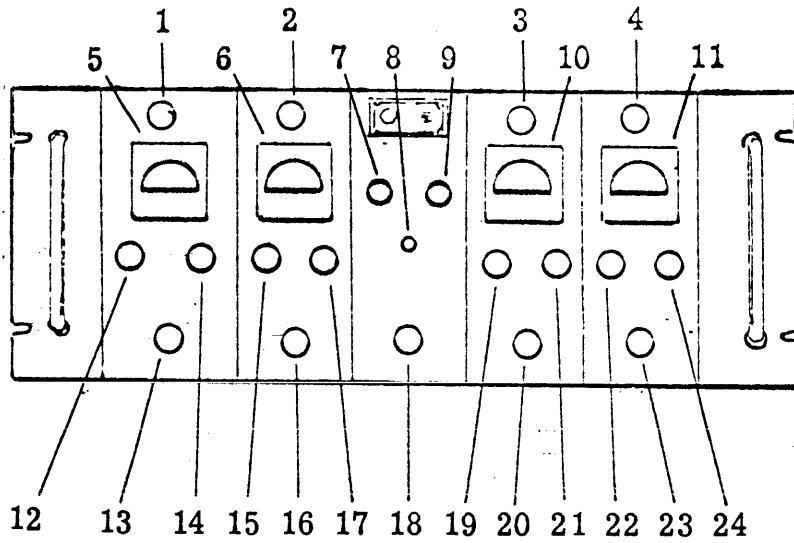

MSA-1

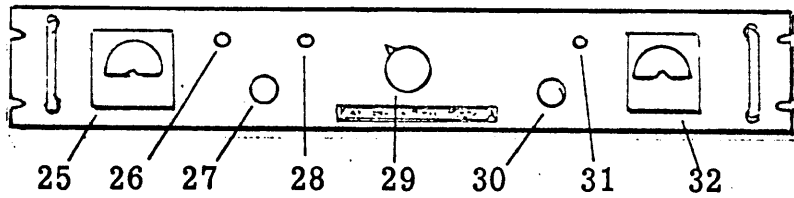

AFC-2A

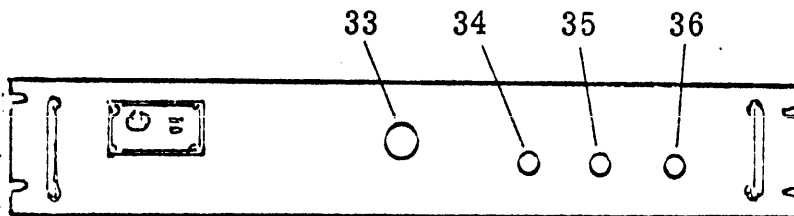

MCG-2I

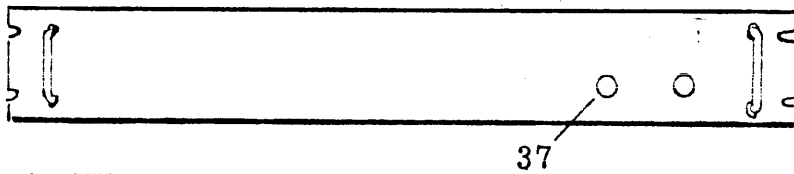

MPS-1

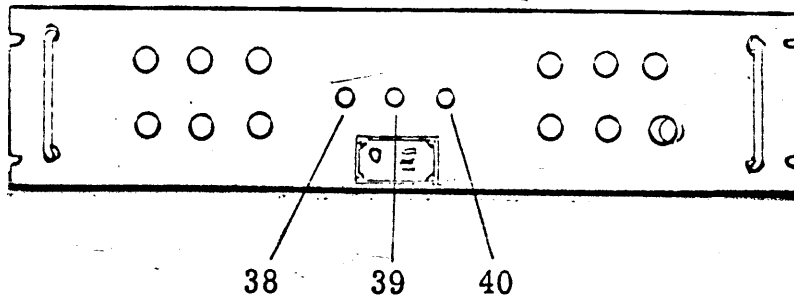

HFP-1A

Figure 3-1. Controls and Indicators

SECTION 4

PRINCIPLES OF OPERATION

4-1. INTRODUCTION

The MSG accepts a 455 kc composite i-f signal from an associated receiver and produces, at its' output, four demultiplexed audio output channels. The following paragraph will discuss the principles of operation of the MSG modular units at a block diagram level, in reference to figure 4-1. For detailed circuit analysis, refer to the applicable modular unit technical manuals.

4-2. BLOCK DIAGRAM ANALYSIS

A 455 kc composite i-f input signal, applied at J8501 of filter assembly A4298-2, is routed to the MSA converter stage via J6502. The converter stage beats the 455 kc i-f with a 705 kc i-f translating signal derived from the MCG via J6501, to produce a different frequency centered at 250 kc.

The 250 kc composite i-f signal is applied to the inputs of four preamplifiers (A2, A1, B1 and B2) in parallel. The output circuits of the preamplifiers are tuned so each amplifier passes one of the channel sidebands. These sidebands are routed through individual i-f modules to corresponding audio modules.

The MSA audio modules are injected with demultiplexing carrier injection frequencies from the MCG; 250 kc for the A1 and B1 channel audio modules, 256.25 kc for the A2 channel audio module and 243.75 kc for the B2 channel audio module and 243.75 kc for the B2 channel audio module.

A narrow band i-f signal from the associated channel i-f module is routed to the product detector in the audio module. The product detector also receives the proper carrier injection signal of the proper frequency from the MCG. The output of the product detector is the difference of the channel i-f signal and the carrier injection signal. The product detector output is then made available at TB6501.

A 250 kc sample from the Msa is applied to the AFC via J5000. This 250 kc

sample is used by the AFC as a comparison with the AFC unit's 250 kc standard. Any change or drift in the 250 kc sample, derived from the MSA, will produce a distorted output and is corrected by the AFC circuitry. The 250 kc AFC output is routed, via J8008 and J8009 of filter assembly A4288-1, to the 250 kc AFC input of the MCG via J6001. This AFC function is available when the MCG selector switch is set at AFC.

SECTION 5 MAINTENANCE

5-1. PREVENTIVE MAINTENANCE.

In order to prevent equipment failure due to dust, dirt or other destructive elements, it is suggested that a schedule of preventive maintenance be set up and adhered to.

At periodic intervals, the equipment should be removed from its mounting for cleaning and inspection. The wiring and all components should be inspected for dirt, dust, corrosion, grease or other harmful conditions. Remove dust with a soft brush or vacuum cleaner. Remove dirt or grease with any suitable cleaning solvent. Use of carbon tetrachloride should be avoided due to its highly toxic effects. Trichlorethylene or methyl chloroform may be used, providing the necessary precautions are observed.

WARNING

When using toxic solvents, make certain that adequate ventilation exists. Avoid prolonged or repeated breathing of the vapor. Avoid prolonged or repeated contact with skin. Flammable solvents shall not be used on energized equipment or near any equipment from which a spark may be received. Smoking, "hot work", etc. is prohibited in the immediate area.

CAUTION

When using trichlorethylene, avoid contact with painted surfaces, due to its paint removing effects.

5-2. TROUBLESHOOTING

When a piece of equipment has been operating satisfactorily and suddenly fails, the cause of failure may be due to symptoms of past failures or due to component aging.

The first step in troubleshooting is to ascertain that proper equipment voltages are present, interconnecting cables are secure, and that all fuses are in functional condition. Refer to table 5-1, used in conjunction with figure 5-1, for system fuse locations and functions.

NOTE

Never replace a fuse with one of a high rating unless brief continued operation is more important than probable equipment damage. If a fuse burns out immediately after replacement, do not replace it a second time until the cause has been located and corrected.

Visual troubleshooting of the modular unit chassis components and tube conditions may also help localize the fault. Refer to the individual modular unit technical manuals for associated unit troubleshooting procedures.

The following troubleshooting aids are provided:

- a. Interconnection diagram (Figure 2-2).
- b. System block diagram (Figure 4-1).
- c. System fuseing (Table 5-1 and Figure 5-1).

TABLE 5-1. FUSE FUNCTIONS

ITEM NO. (Figure 5-1)	PANEL DESIGNATION	FUNCTION
POWER SUPPLY, MPS		
1	.25A	Input transformer secondary.
POWER SUPPLY, HFP		
2	B-LINE .125A	Section "B"B-output to J8010.
3	B-LINE .125A	Section "B"B-output to J8008.
4	B+LINE .250A	Section "B"B+ output to J8005 and J8008.
5	B-LINE .125A	Section "B"B-output to J8006.
6	B+LINE .375A	Section "A"B+ output to J8007.
7	B+LINE .375A	Section "A:B+ output to J8005.
8	FIL LINE 4A	6.8 vac output to J8006.
9	FIL LINE 5A	6.8 vac output to J8009.
10	FIL LINE 15A	6.8 vac output to J8007.
11	FIL LINE	6.8 vac output to J8010.
12	FIL LINE 10A	6.8 vac output to J8008.
13	FIL LINE 10A	6.8 vac output to J8005.
14	F8003 4A/115V 2A/230V	Line voltage supply to J8009 and J8010; 6.3 vac supply to J8005; time delay and circuit in HFP.
15	F8007 .750A	Input to section "A"B+ regulator in HFP.
16	F8008 .750A	Input to section "B"B+ regulator in HFP.
17	F8001 15A/115V 8A/230V	Main line voltage input and line voltage output to J8002.
18	F8004 4A/115V 2A/230V	Line voltage supply to J8009 and J8010; 6.3 vac supply to J8005; time delay and filament circuits in HFP.
19	F8005 2A/115V	Line voltage supply to J8004.
20	F8006 1.10A	Input to bias supply in HFP.
21	F8002 15A/115V 8A/230V	Main line voltage input and line voltage output to J8002.

CAUTION

Do not replace a fuse with one of a higher rating. If a fuse burns out immediately after replacement, do not replace it a second time until the trouble has been located and corrected.

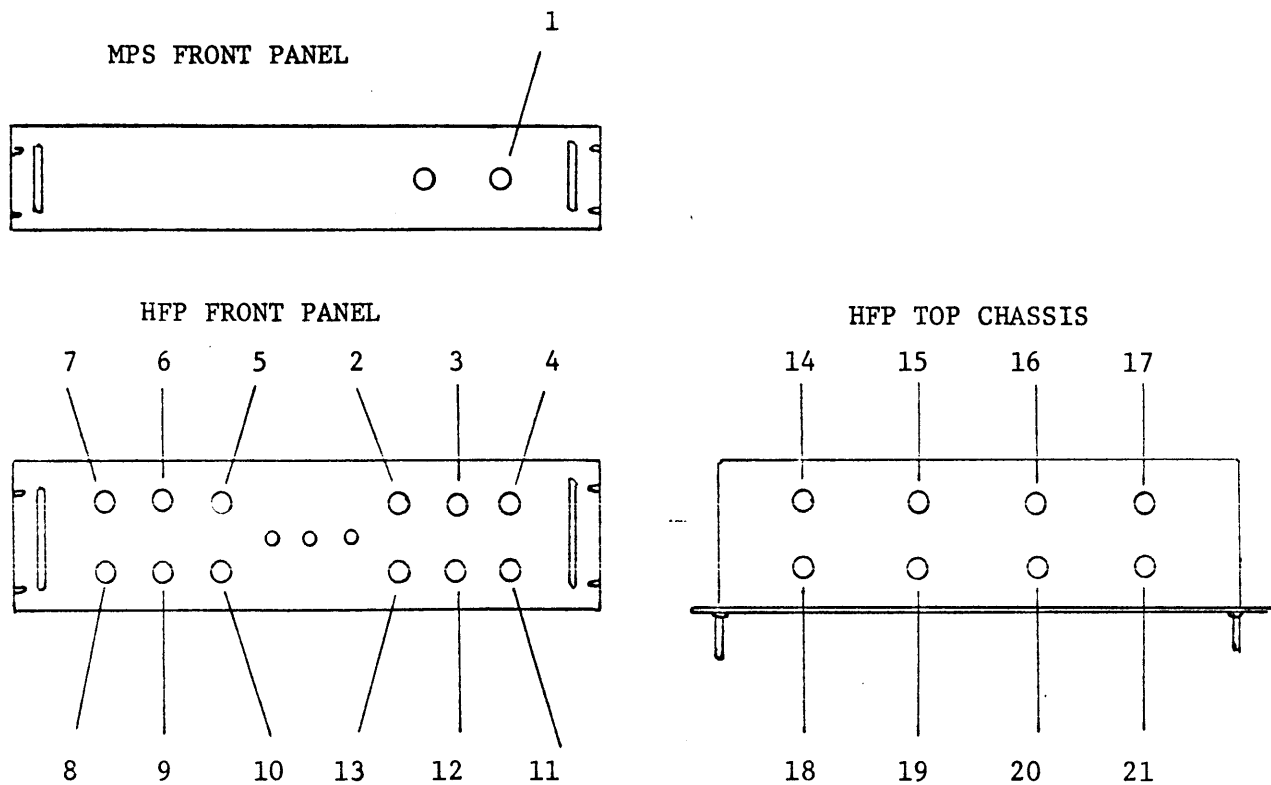

Figure 5-1. FUSE LOCATIONS

5-3. REPAIR AND REPLACEMENT

Maintenance of the MSG will consist mainly of component replacement. It should be noted that when replacing components having many wires connected, such as switches, relays, etc., the wires should be tagged and marked for accurate identification when replacing.

When replacing components, the technician should observe for exact or equivalent replacements by referring to the parts list of the appropriate modular unit technical manual.

Polarity and positioning of certain components should be observed before removing so that the replacement component will fit and operate correctly.

5-4. OPERATIONAL CHECKS

The following checks are derived from factory test procedures, modified for field service use. Refer to table 5-2 for test equipment required.

a. PRELIMINARY

- (1) Check system for obvious mechanical or electrical defects.
- (2) Connect main power cable to 115 volts a-c, single phase source.
- (3) Check that ovens in MCG are warming and cycling. Observe HR6001, HR6002 and HR6003; the MPS should be on.
- (4) Set HFP at STANDBY condition.
- (5) Set MSA switch at OPERATE.
- (6) The HFP should go into TIME DELAY condition.
- (7) After a time lapse, not to exceed 90 seconds, the HFP should switch into the OPERATE condition.
- (8) Connect 600-ohm resistors across output terminals of audio output filter A4298-2.

b. PROCEDURE

- (1) Set AGC DECAY and SQUELCH to full counter-clockwise setting on MSA.
- (2) Set MCG switch at INTERNAL.
- (3) Connect signal generator to input jack (IF, J8501) on A4298-2.
- (4) Set signal generator to 455 kc, with 3 mv output.
- (5) Set LINE LEVEL control about 1/4-turn clockwise.
- (6) Vary signal generator output slowly until an indication on channel B2 VU meter on MSA is observed. Adjust B2 LINE LEVEL for 0 VU reading.
- (7) Check audio output B2 terminals (TB8501 on A4298-2) for signal. With meter, measure each side of 600-ohm resistor to ground; it should read approximately .33 VAC.
- (8) Repeat steps 6 and 7 for each channel (A1, A2 and B1).
- (9) Set MCG switch at AFC; the AFC unit should switch to OPERATE condition, indicated by the FADE and LEVEL alarm indicators lighting.
- (10) Set AFC tuning to -3 KC. Slowly sweep AFC tuning to +3 KC. As this is done, the MSA channels should actuate in the following sequence: A2, A1, B1 and B2.
- (11) Set MCG switch at INTERNAL.
- (12) Connect frequency counter to J6003 on MCG.
- (13) On MCG, adjust C6002 for 250 kc, \pm .2 cps.

- (14) Connect frequency counter to J6012 on MCG.
- (15) On MCG, adjust C6010 for 705 kc, \pm .2 cps.
- (16) Connect frequency counter to pin 1 of V6003.
- (17) Adjust Z6001 (rear of unit) for 100.00 kc, \pm .01 cps.

Table 5-2. Test Equipment Required

DESCRIPTION	MANUFACTURER
Signal Generator	Measurements, Model 82 or equivalent.
AC VTVM	Ballantine, Model 314 or equivalent.
Frequency Counter	Hewlett-Packard, Model 524C or equivalent.
Four 600-ohm, 1/2 watt resistors.	Any manufacturer meeting the necessary requirements.
Coaxial cable, 6-feet long, femal BNC connectors on each end.	Any manufacturer meeting the necessary requirements.

SECTION 6

PARTS LIST

6-1. INTRODUCTION

The parts list presented in this section is a cross-reference list of parts identified by a reference designation and TMC part number. In most cases, parts appearing on schematic diagrams are assigned reference designations in accordance with MIL-STD-16. Wherever practicable, the reference designation is marked on the equipment, close to the part it identifies. In most cases, mechanical and electro-mechanical parts have TMC part numbers stamped on them.

To expedite delivery when ordering any part, specify the following:

- a. Reference symbol.
- b. Description as indicated in parts list.
- c. TMC part number.
- d. Model and serial numbers of the equipment containing the part being replaced; this can be obtained from the equipment nameplate.

For replacement parts not covered by warranty (refer to warranty sheet in front of manual), address all purchase orders to:

The Technical Materiel Corporation
Attention: Sales Department
700 Fenimore Road
Mamaroneck, New York

PARTS LIST

for

INDEPENDENT AGC RECEIVING SYSTEM, MSG-3I

REF SYMBOL	DESCRIPTION	TMC PART NUMBER
J8508	CONNECTOR, RECEPTACLE, ELECTRICAL: 1 female contact; maximum peak operating voltage 500 volts; beryllium copper; BNC series.	UG625*/U
J8509	Same as J8508.	
P5000	CONNECTOR, PLUG, ELECTRICAL: 1 male contact, voltage rating 500 V peak; polarized; series BNC. Part of W8502.	PL244-1
P5001	CONNECTOR, PLUG, ELECTRICAL: 14 round number 16 male contacts; straight type. Part of W8501.	PL212-1
P5002	Same as P5000. Part of W8502.	
P5003	Same as P5000. Part of W8502.	
P6001	Same as P5000. Part of W8502.	
P6002	NOT USED.	
P6003	Same as P5000. Part of W8502.	
P6004	NOT USED.	
P6005	Same as P5000. Part of W8502.	
P6006	NOT USED.	
P6007	Same as P5000. Part of W8502.	
P6008	NOT USED.	
P6009	Same as P5000. Part of W8502.	
P6010	NOT USED.	
P6011	Same as P5000. Part of W8502.	
P6012	NOT USED.	
P6013	NOT USED.	
P6014	Same as P5000. Part of W8502.	
P6015	CONNECTOR, PLUG, ELECTRICAL: 14 round number 16 female contacts; straight type. Part of W8504.	PL212-2

PARTS LIST

for

INDEPENDENT AGC RECEIVING SYSTEM, MODEL MSG-3I

REF SYMBOL	DESCRIPTION	TMC PART NUMBER
P6016 thru P6079	NOT USED.	
P6080	Same as P5001. Part of W8505.	
P6081	CONNECTOR, PLUG, ELECTRICAL: 2 female contacts, rated for 10 amps at 250 V; polarized; twist lock; midget size; brown bakelite. Part of W8506.	PL176
P6501	Same as P5000. Part of W8502.	
P6502	CONNECTOR, RECEPTACLE, ELECTRICAL: 1 round female contact; straight type; series BNC to BNC.	JJ172
P6503 thru P6506	NOT USED.	
P6507	Same as P5000. Part of W8502.	
P6508 thru P6514	NOT USED.	
P6515-1	CONNECTOR, PLUG, ELECTRICAL: 24 round number 20 female contacts; straight type. Part of W8503.	PL212-4
P6516 thru P6536	NOT USED.	
P6537	Same as P5000. Part of W8502.	
P6538	NOT USED.	
P6539	Same as P5000. Part of W8502.	
P6540	NOT USED.	
P6541	Same as P5000. Part of W8502.	
P6542	NOT USED.	
P6543	Same as P5000. Part of W8502.	
P8001	Same as P6081. Part of W8514. (Supplied as loose item)	

PARTS LIST

for

INDEPENDENT AGC RECEIVING SYSTEM, MODEL MSG-3I

REF SYMBOL	DESCRIPTION	TMC PART NUMBER
P8002	CONNECTOR, PLUG, ELECTRICAL: AC; 3 prong; polarized; with removeable ground connection. Part of W8506.	PL218
P8003-1	Same as P6515-1. Part of W8503.	
P8004	NOT USED.	
P8005-1	Same as P6515-1. Part of W8503.	
P8006	NOT USED.	
P8007	NOT USED.	
P8008	Same as P6015. Part of W8504.	
P8009	Same as P5001. Part of W8501.	
P8010	Same as P6080. Part of W8505.	
P8502	Same as P6515-1. Part of W8507.	
P8503 thru P8507.	NOT USED.	
P8508	Same as P5000. Part of W8502.	
P8509	Same as P5000. Part of W8502.	
R8501	RESISTOR, FIXED, COMPOSITION: 100 ohms, $\pm 5\%$; 1/2 watt.	RC20GF101J
R8502	RESISTOR, FIXED, COMPOSITION: 39 ohms, $\pm 5\%$; 1/2 watt.	RC20GF390J
TB6501	TERMINAL STRIP, BARRIER: sixteen 6-32 thd. x 1/4" long binder head machine screws; black bakelite body. Part of W8507.	TM100-16
W8501	CABLE ASSEMBLY, SPECIAL PURPOSE: consists of 2 connectors, P5001 and P8009.	CA1044-11
W8502	WIRING HARNESS, BRANCHED: consists of 18 connectors, P5000, P5002, P5003, P6001, P6003, P6005, P6007, P6009, P6011, P6014, P6501, P6507, P6537, P6539, P6541, P6543, P8508 and P8509.	CA1343

PARTS LIST

for

INDEPENDENT AGC RECEIVING SYSTEM, MODEL MSG-3I

REF SYMBOL	DESCRIPTION	TMC PART NUMBER
W8503	WIRING HARNESS, BRANCHED: consists of 3 connectors, P6515-1, P8003-1 and P8005-1.	CA1104-1
W8504	WIRING HARNESS, BRANCHED: consists of 2 connectors, P6015 and P8008.	CA1033-9
W8505	WIRING HARNESS, BRANCHED: consists of 2 connectors, P6080 and P8010.	CA1345
W8506	CABLE ASSEMBLY, ELECTRICAL: power; consists of 2 connectors, P6081 and P8002.	CA555-4
W8507	CABLE ASSEMBLY, SPECIAL PURPOSE: consists of 1 Terminal Strip, Barrier, TB6501 and 1 connector P8502.	CA1149-1
W8508	CABLE ASSEMBLY, ELECTRICAL: RF; consists of 1 connector, P6502.	CA480-15-10F
W8509	LEAD, ELECTRICAL: grounding wire.	CA412-36-34.00
W8510	LEAD, ELECTRICAL: grounding wire.	CA412-36-64.00
W8511	LEAD, ELECTRICAL: grounding wire.	CA412-36-47.00
W8512	LEAD, ELECTRICAL: grounding wire.	CA412-36-35.00
W8513	Same as W8512.	
W8514	CABLE ASSEMBLY, ELECTRICAL: power; consists of 1 connector P8001. (Supplied as loose item)	CA696-1
	<p><u>LOOSE ITEM LIST</u></p> <p>TERMINAL BOARD, FANNING: 16 terminals, angle type, right end feed.</p> <p>SCREW DRIVER, FLAT: 8" long.</p> <p>SOCKET WRENCH: 3/16"</p> <p>ALIGNMENT TOOL</p> <p>CONNECTOR, PLUG, ELECTRICAL: 31/32" long x 9/16" diameter; bayonet type, series BNC. Quantity Six.</p>	<p>TM105-16AR</p> <p>TP116-1</p> <p>TP117-1</p> <p>TP119-1</p> <p>UG88*/U</p>