

TECHNICAL MANUAL  
*for*

HIGH FREQUENCY TRANSMITTER

MODEL HFTM-1KJ2

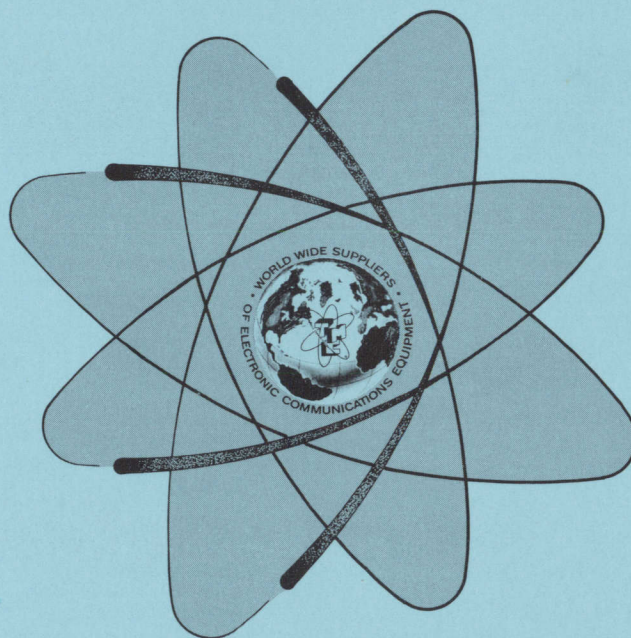

THE TECHNICAL MATERIEL CORPORATION  
MAMARONECK, N.Y.

OTTAWA, ONTARIO

COPYRIGHT 1971  
THE TECHNICAL MATERIEL CORPORATION

Printed in U.S.A.

TECHNICAL MANUAL  
*for*

HIGH FREQUENCY TRANSMITTER

MODEL HFTM-1KJ2

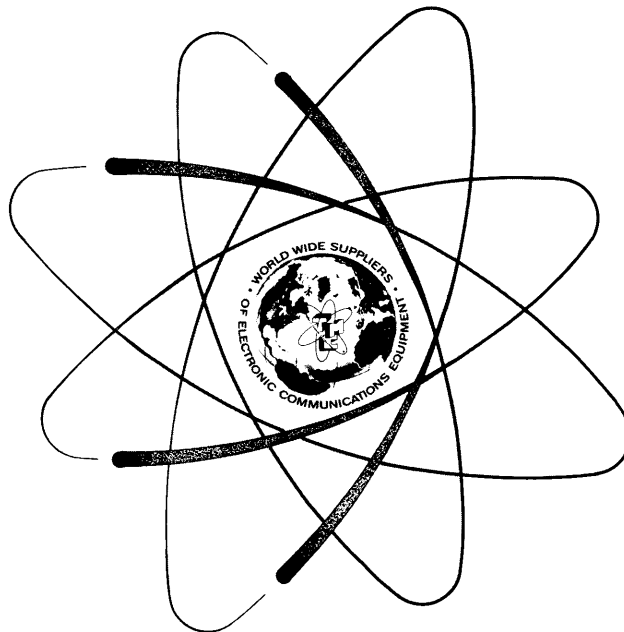

THE TECHNICAL MATERIEL CORPORATION  
MAMARONECK, N.Y.

OTTAWA, ONTARIO

COPYRIGHT 1971  
THE TECHNICAL MATERIEL CORPORATION

Printed in U.S.A.

IN 1079

Issue Date: APRIL 1973

## NOTICE

THE CONTENTS AND INFORMATION CONTAINED IN THIS INSTRUCTION MANUAL IS PROPRIETARY TO THE TECHNICAL MATERIEL CORPORATION TO BE USED AS A GUIDE TO THE OPERATION AND MAINTENANCE OF THE EQUIPMENT FOR WHICH THE MANUAL IS ISSUED AND MAY NOT BE DUPLICATED EITHER IN WHOLE OR IN PART BY ANY MEANS WHATSOEVER WITHOUT THE WRITTEN CONSENT OF THE TECHNICAL MATERIEL CORPORATION.

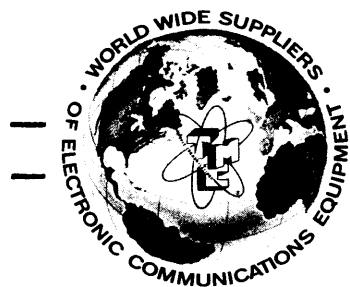

# THE TECHNICAL MATERIEL CORPORATION

C O M M U N I C A T I O N S   E N G I N E E R S

700 FENIMORE ROAD

MAMARONECK, N. Y.

## W a r r a n t y

The Technical Materiel Corporation, hereinafter referred to as TMC, warrants the equipment (except electron tubes,\* fuses, lamps, batteries and articles made of glass or other fragile or other expendable materials) purchased hereunder to be free from defect in materials and workmanship under normal use and service, when used for the purposes for which the same is designed, for a period of one year from the date of delivery F.O.B. factory. TMC further warrants that the equipment will perform in a manner equal to or better than published technical specifications as amended by any additions or corrections thereto accompanying the formal equipment offer.

TMC will replace or repair any such defective items, F.O.B. factory, which may fail within the stated warranty period, PROVIDED:

1. That any claim of defect under this warranty is made within sixty (60) days after discovery thereof and that inspection by TMC, if required, indicates the validity of such claim to TMC's satisfaction.
2. That the defect is not the result of damage incurred in shipment from or to the factory.
3. That the equipment has not been altered in any way either as to design or use whether by replacement parts not supplied or approved by TMC, or otherwise.
4. That any equipment or accessories furnished but not manufactured by TMC, or not of TMC design shall be subject only to such adjustments as TMC may obtain from the supplier thereof.

Electron tubes\*furnished by TMC, but manufactured by others, bear only the warranty given by such other manufacturers. Electron tube warranty claims should be made directly to the manufacturer of such tubes.

TMC's obligation under this warranty is limited to the repair or replacement of defective parts with the exceptions noted above.

At TMC's option any defective part or equipment which fails within the warranty period shall be returned to TMC's factory for inspection, properly packed with shipping charges prepaid. No parts or equipment shall be returned to TMC, unless a return authorization is issued by TMC.

No warranties, express or implied, other than those specifically set forth herein shall be applicable to any equipment manufactured or furnished by TMC and the foregoing warranty shall constitute the Buyers sole right and remedy. In no event does TMC assume any liability for consequential damages, or for loss, damage or expense directly or indirectly arising from the use of TMC Products, or any inability to use them either separately or in combination with other equipment or materials or from any other cause.

\*Electron tubes also include semi-conductor devices.

### *PROCEDURE FOR RETURN OF MATERIAL OR EQUIPMENT*

Should it be necessary to return equipment or material for repair or replacement, whether within warranty or otherwise, a return authorization must be obtained from TMC prior to shipment. The request for return authorization should include the following information:

1. Model Number of Equipment.
2. Serial Number of Equipment.
3. TMC Part Number.
4. Nature of defect or cause of failure.
5. The contract or purchase order under which equipment was delivered.

### *PROCEDURE FOR ORDERING REPLACEMENT PARTS*

When ordering replacement parts, the following information must be included in the order as applicable:

1. Quantity Required.
2. TMC Part Number.
3. Equipment in which used by TMC or Military Model Number.
4. Brief Description of the Item.
5. The *Crystal Frequency* if the order includes crystals.

### *PROCEDURE IN THE EVENT OF DAMAGE INCURRED IN SHIPMENT*

TMC's Warranty specifically excludes damage incurred in shipment to or from the factory. In the event equipment is received in damaged condition, the carrier should be notified immediately. Claims for such damage should be filed with the carrier involved and not with TMC.

All correspondence pertaining to Warranty Claims, return, repair, or replacement and all material or equipment returned for repair or replacement, within Warranty or otherwise, should be addressed as follows:

THE TECHNICAL MATERIEL CORPORATION  
Engineering Services Department  
700 Fenimore Road  
Mamaroneck, New York



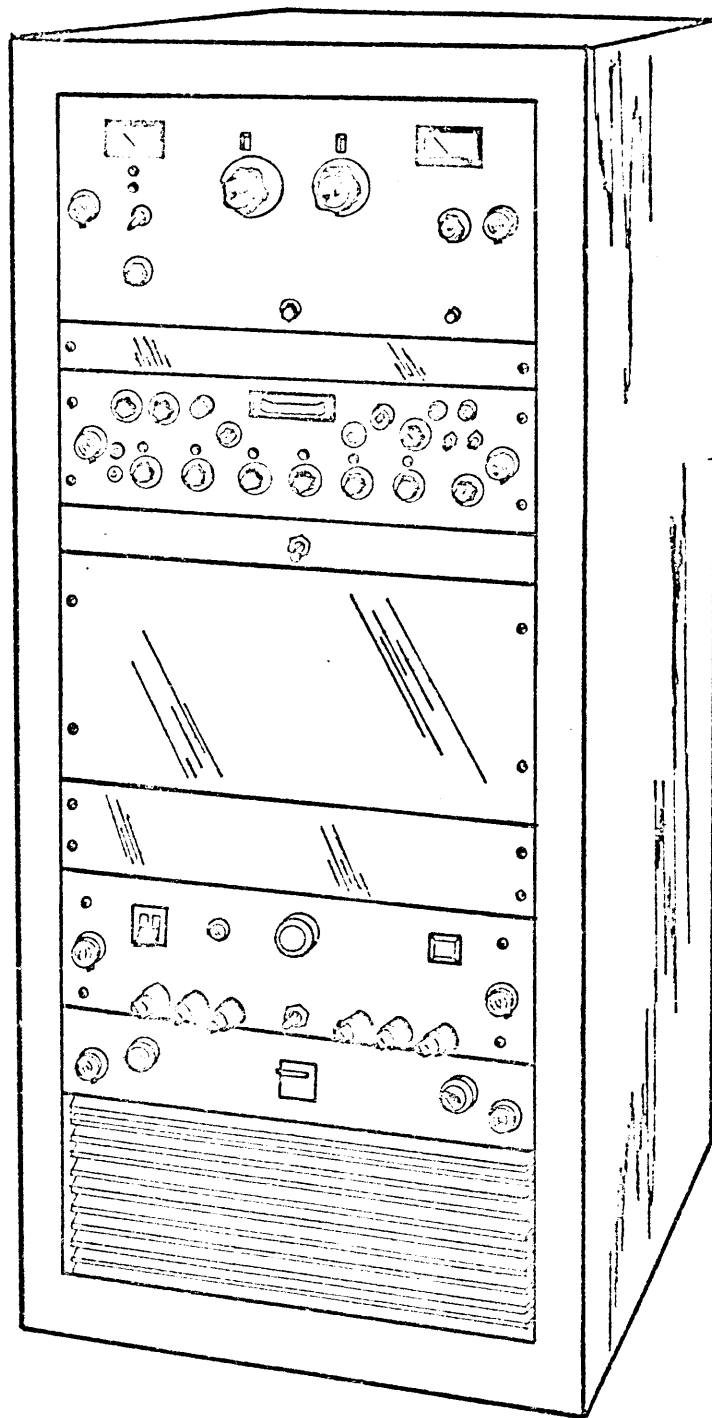

Figure 1-1. HFTM-1KJ2 High Frequency Transmitter

## SECTION 1

### GENERAL INFORMATION

#### 1-1. FUNCTIONAL DESCRIPTION.

This manual presents operating and maintenance instructions for the High Frequency Transmitter, Model HFTM-1KJ2, designed and manufactured by the Technical Materiel Corporation, Mamaroneck, New York. This manual includes a general description of the equipment; installation and operating procedures; principles of operation; maintenance and troubleshooting data; and a parts list.

High Frequency Transmitter, Model HFTM-1KJ2 (shown in figure 1-1), hereinafter referred to as the HFTM-1KJ2 or the transmitter, consists of a solid state, multi-mode, exciter MMX(M)-2, used in conjunction with a high frequency linear power amplifier, HFIM-1K (revision A type). The exciter is capable of providing CW (continuous wave), AM (amplitude modulation), SSB (single sideband) including AME (amplitude modulated equivalent) full carrier, FSK (frequency shift keying), FAX (facsimile) and optional ISB (independent sideband) modes of operation. The high frequency linear power amplifier amplifies the exciter output to provide 1 kilowatt PEP (peak envelope power) and average throughout the frequency range of 1.5 to 30 mhz. The transmitter is readily adaptable for shipboard, aircraft, and land installations.

This individual manual covers the transmitter as a system. For complete information on the HFTM-1KJ2, the modular manuals, Technical Manual for Multi-Mode Exciter Model MMX(M)-2 and Technical Manual for Linear Power Amplifier Model HFIM-1K, should be used in conjunction with this transmitter system manual.

#### 1-2. PHYSICAL DESCRIPTION.

As shown in figure 1-1, the transmitter consists of a single equipment cabinet, 49-3/8 inches high by 23 inches wide by 27 1/2 inches deep, which houses the MMX(M)-2 exciter, the AX5040 test key panel, and all units which comprise the HFIM-1K linear power amplifier. The HFIM-1K consists of a two-stage broadband linear amplifier, power amplifier and associated power supplies and control circuits. Table 1-1 lists the transmitter components; Figure 1-2 shows the physical location of transmitter components.



TABLE 1-1. COMPONENTS OF HIGH FREQUENCY TRANSMITTER HFTM-1KJ2

NOIENCLATURE	COMMON NAME
MMX(M)-2	MULTI-MODE EXCITER
AX5040	TEST KEY PANEL
HFLM-1K consisting of: TLAM-1K AP-151 AP-152	LINEAR POWER AMPLIFIER  RF LINEAR POWER AMPLIFIER LOW VOLTAGE AND BIAS SUPPLY HIGH VOLTAGE POWER SUPPLY
RAK139-1A	EQUIPMENT CABINET

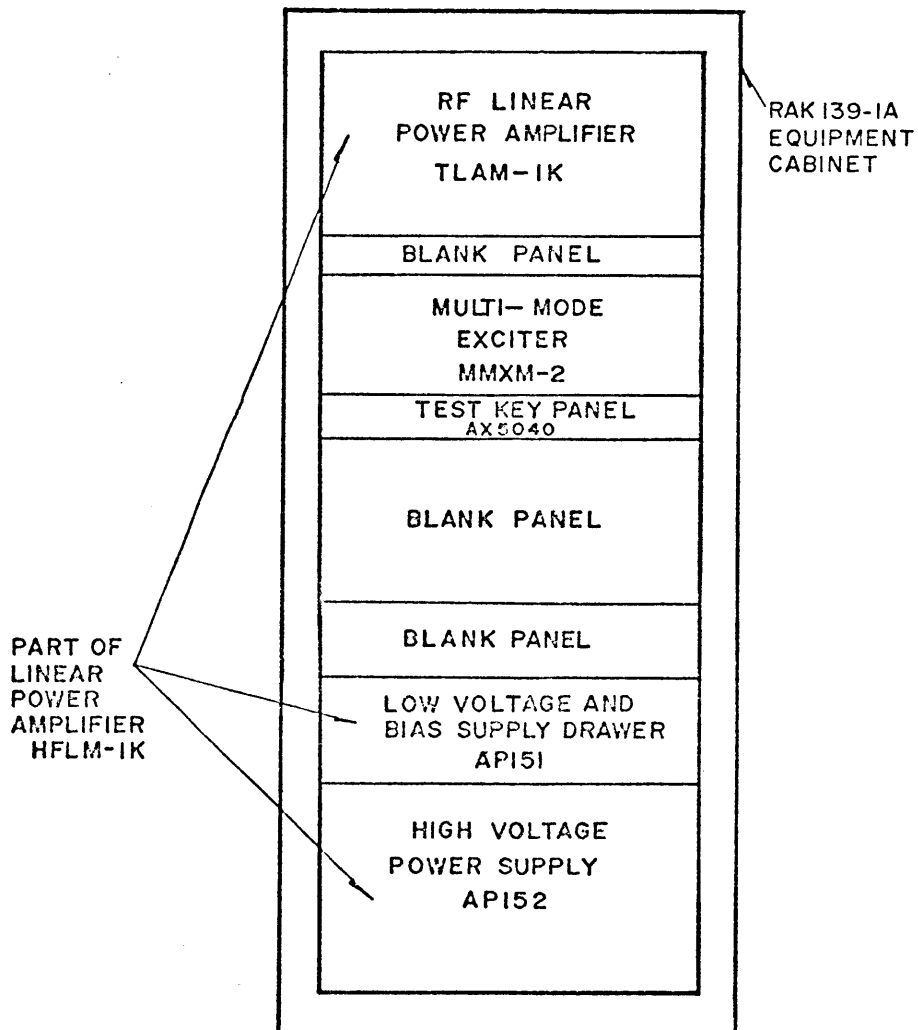

Figure 1-2. Physical Configuration of HFTM-1KJ2

Primary power connection to the transmitter is made at the bottom rear of the equipment cabinet; external input and output connections are made through either of two access holes in the bottom rear and side of the equipment cabinet. RF output power is routed through a directional coupler mounted in the HPLM-1K to the output connector (J10) located on the interface panel in the rear of the transmitter.

1-3. REFERENCE DATA.

Table 1-2 lists the technical specifications of the transmitter. Table 1-3 lists the power tube complement of the transmitter.

TABLE 1-2. TECHNICAL SPECIFICATIONS

Frequency Information	
Range	2 to 30 MHz is Standard; 1.5 to 30 MHz is Optional
Stability Synthesized	One part in $10^8$ per day is Standard
Operational	
Modes	CW(A1), AM(A3), AME(A3H), USB(A3A), LSB, two-channel ISB (A3B), FSK(F1, A7J) and FAX(F4, A7J) capability is available
Carrier Suppression	Front panel selectable: full carrier, -6 db, -16 db or fully suppressed (greater than -55 db)
Power Output	1000 watts PEP and AVERAGE (CW) continuous, key-down service
Output Impedance	50 ohms nominal unbalanced; 70 ohms nominal Optional
VSWR	Maximum of 2:1 without degrading performance
Tuning	Manual
ALDC	Automatic Load and Drive Control to improve linearity, limit distortion, and maintain a relatively constant output level during high modulation peaks and load changes. Front panel control allows adjustment of the level at which the ALDC takes effect.

TABLE 1-2. TECHNICAL SPECIFICATIONS (CONT)

Power Distortion and Noise Ratings	
Spurious Signals	At least 50 db down from full PEP output
Noise Level	At least 50 db down from full PEP output
Unwanted Sideband	Better than 50 db rejection referenced to full PEP output
Intermodulation	Distortion products are at least 35 db below either tone of a standard two-tone test at full rated PEP
Audio	
Sideband Response	$\pm 1.5$ db, 250-3040 Hz or 250-6080 Hz
Input	<ol style="list-style-type: none"> <li>1) Two independent 600-ohm channels, balanced or unbalanced. -20 dbm to +5 dbm input will permit full power output.</li> <li>2) Built-in microphone preamplifier for low level dynamic microphone. Front panel selection and jack. Mike input -55 db into 47K ohms with front panel jack.</li> </ol>
Keying Information	
CW	Key jack on front panel and terminals on rear apron allow up to 300 WPM carrier keying, dry contact.
FSK	50 to 100 baud with neutral or polar keying
FAX	+1 to +10 VDC will provide a linear shift of 800 Hz
Installation and Environmental Data	
Environmental	Operates 0 to +50°C with up to 90% relative humidity
Cooling	High capacity, filtered, forced air
Primary Power	115/230 VAC, 50/60 Hz, Single Phase at 3.75 kilowatts

TABLE 1-3. TRANSMITTER POWER TUBE COMPLEMENT

REFERENCE DESIGNATION	PART NUMBER OR TYPE	FUNCTION
V1201 V1202 V1301	8233 4CX350A 8576	1st RF Amplifier 2nd RF Amplifier Power Amplifier

## SECTION 2

### INSTALLATION

#### 2-1. INITIAL UNPACKING AND INSPECTION.

The RMT-12J2 transmitter was assembled, calibrated and tested at the factory before shipment. Inspect all packages for possible damage during transit. With respect to damage to the equipment for which the carrier is liable, The Technical Materiel Corporation will assist in describing methods of repair and furnishing of replacement parts. Carefully unpack each crate as indicated by the packing list provided with the transmitter shipment. Inspect all packing materials for parts that may have been shipped as loose items (cabinet hardware, connectors, technical manuals, etc.) Refer to figure 2-1 for typical preparation for shipments.

#### 2-2. POWER REQUIREMENTS.

The transmitter requires a single phase source of 115/230 vac, 50/60 hz at approximately 3.75 kilowatts.

#### 2-3. INSTALLATION.

a. General. A minimum number of assemblies, subassemblies, components and hardware have been disassembled from the equipment and separately packaged, thus reducing the possibility of equipment damage in transit. The method of disassembly and separate packaging also permits realistic equipment handling.

Cables, wires, and other miscellaneous items that are disconnected during equipment disassembly are tagged and taped to the equipment. The information on a given tag indicates the designated terminal on a component to which the tagged item must be connected. Make sure all cables and wires have been connected as designated on tags and that all packing material, tags and tape have been removed before sealing-up the cabinet or section of the cabinet with a front panel drawer.

b. Equipment Cabinet Installation. Remove equipment cabinet from crate and position upright (mounting holes and primary power input jack are located on the bottom portion of the equipment cabinet). Position the equipment cabinet in the desired location, allowing a minimum clearance of two feet on the top and all sides for maintenance and installation purposes. (Refer to figure 2-2 for cabinet dimensions.) It is of particular importance that a minimum clearance of two feet be allowed in the rear of the cabinet for door removal and external cable connections.

Using mounting hardware and the holes located in the base of the cabinet, secure the equipment cabinet in position. (Refer to figure 2-2 for mounting detail.)

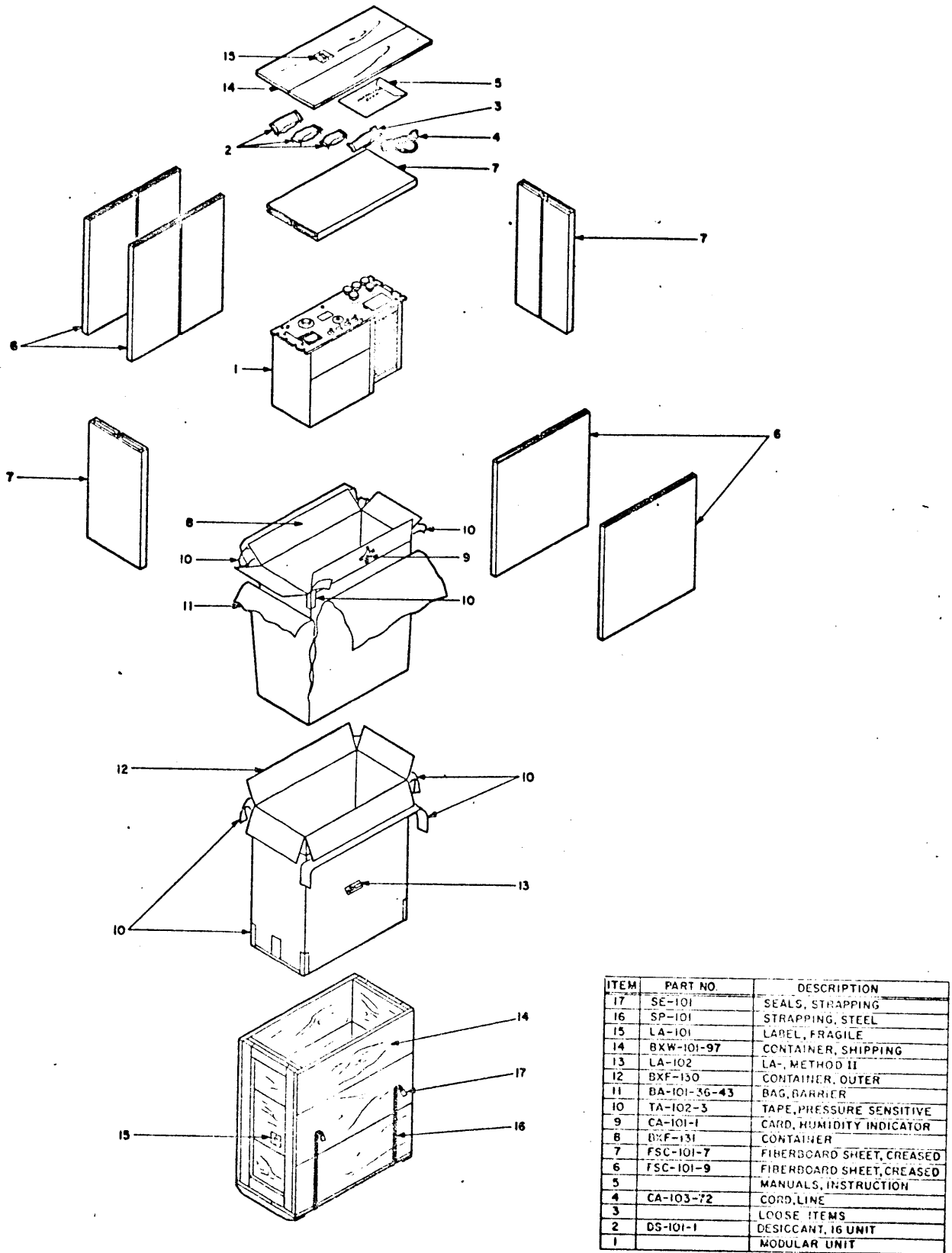

Figure 2-1. Modular Units, Typical Preparation for Shipment

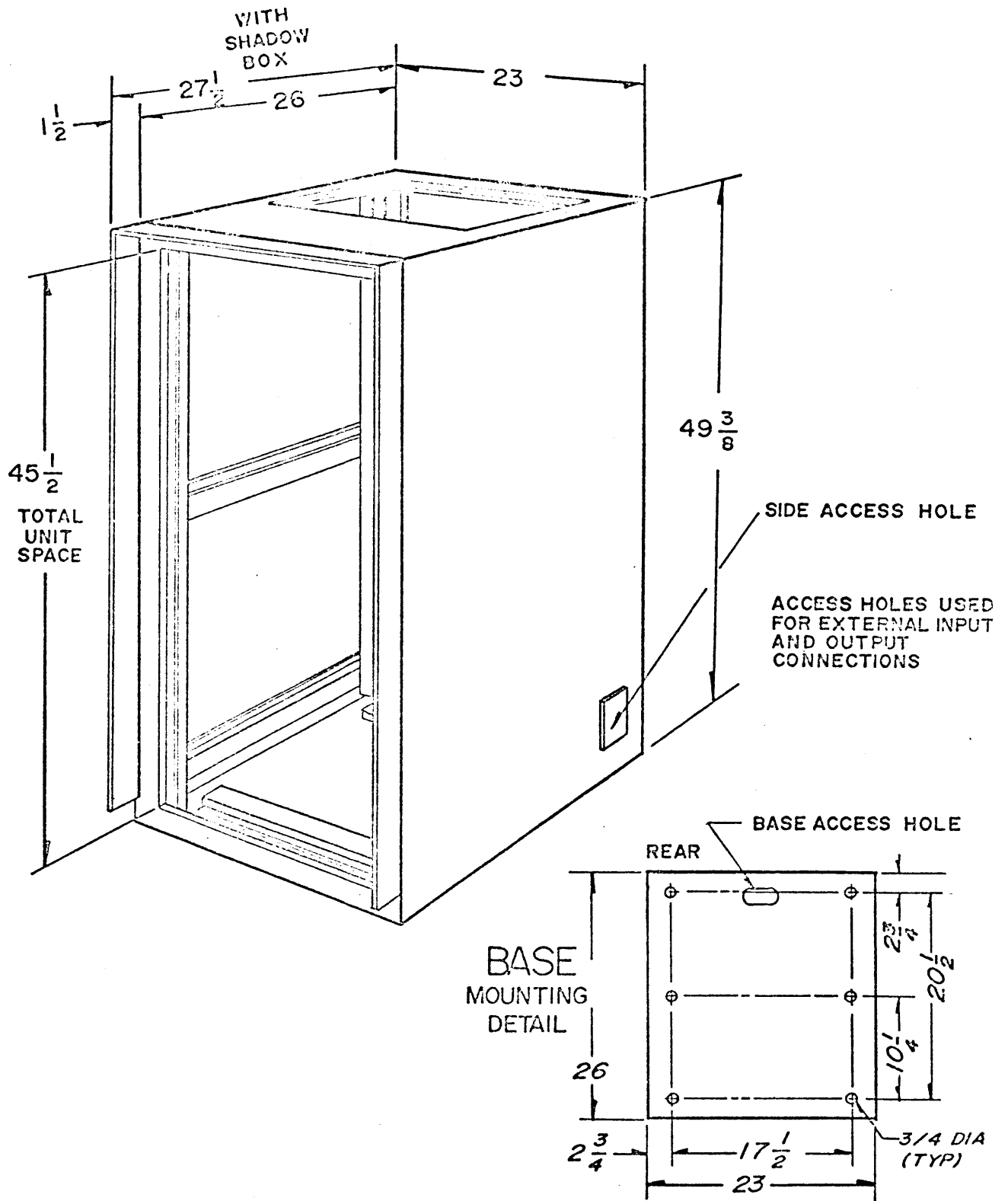

Figure 2-2. Equipment Cabinet Dimensions

c. Modular Unit Installation. The component location for modular unit installation in the HFTM-1KJ2 transmitter is shown in figure 2-3. Except for the AX5040 test key panel, all transmitter units are slide mounted. The modular units of the HFIM-1K should be installed into the equipment cabinet by referring to the detailed installation procedural steps in Section 2 of Technical Manual for Linear Power Amplifier HFIM-1K. The exciter unit MMX(M)-2 should be installed in the same manner.

WARNING

BEFORE MAKING EXTERNAL CONNECTIONS TO THE TRANSMITTER, INSURE THAT THE EXTERNAL PRIMARY POWER IS OFF AND TAGGED.

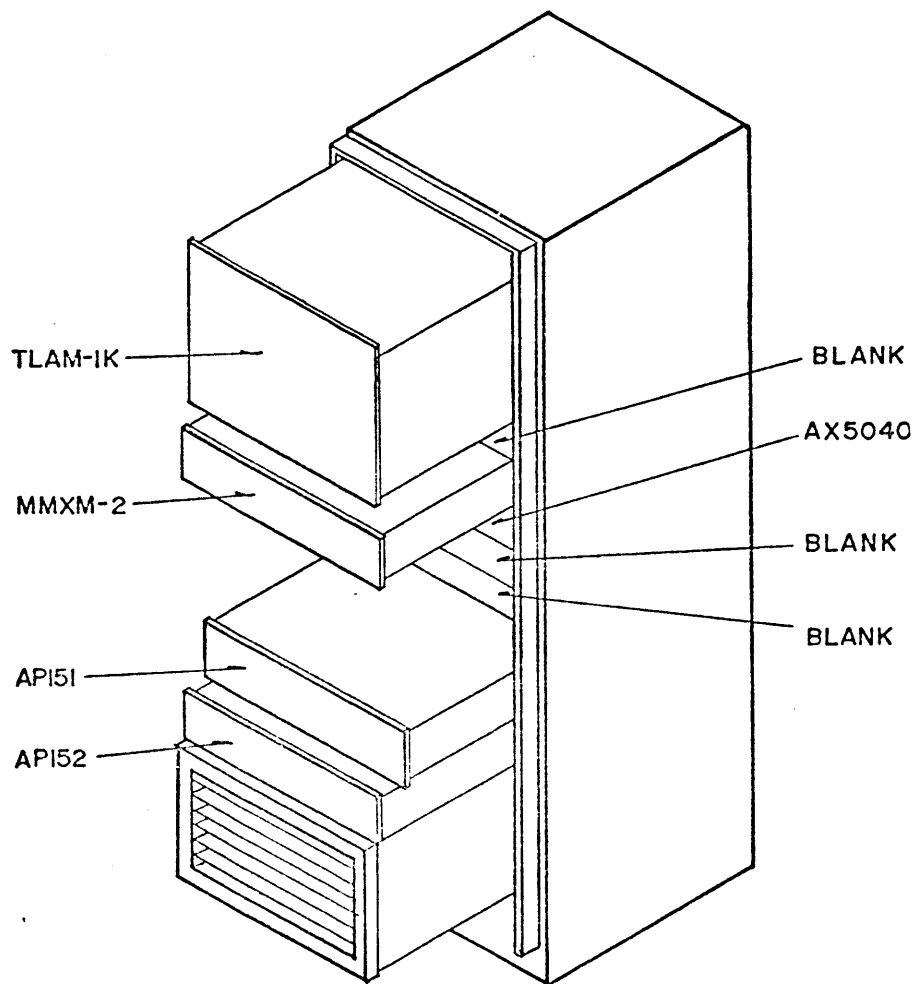

Figure 2-3. HFTM-1KJ2 Modular Unit Installation



d. Electrical Interconnections. Once the modular units have been installed in the equipment cabinet, connect all plugs to their respective jacks (refer to figure 2-4 for interconnect wiring and to figure 2-6 for connector locations). All interconnect cables are marked with their respective J reference numbers (jacks) and mating P reference numbers (plugs) for ease of installation.

e. External Connections. External input and output connections are made to the transmitter at the interface panel, located in the rear of the equipment cabinet. As shown in figure 2-5, the interface panel consists of nine terminal jacks which provide a termination point for intelligence inputs, external transmitter control inputs, and transmitter status indicator outputs. If external transmitter control lines are not provided and connected to J7 on the interface panel, jumper connections must be added at terminal jack J7 to complete circuits within the transmitter, enabling operation. Refer to figure 2-4 and Table 2-1 for information pertaining to external connections and/or control jumpers. Figure 2-4 is the interconnect wiring diagram; Table 2-1 lists the external interface panel connections and their functions. Additionally, Table 2-2 lists the connecting plugs and jacks which are supplied with the transmitter as loose items; these plugs and jacks are for external connections to the transmitter at the interface panel.

TABLE 2-1. EXTERNAL CONNECTIONS TO INTERFACE PANEL

EXCITER CONTROL JACK J6	
DESIGNATION	FUNCTION/CONNECTION
USB	600 ohm audio input lines; connect to pins A,B and C. Use a shielded pair.
LSB	600 ohm audio input lines; connect to pins E,F and G. Use a shielded pair.
FSK	Frequency shift keying line; connect (+) to pin L and (-) to pin K.
FAX	Facsimile input line; connect across pins N and Q. Pin Q is ground.
FSK CONTACT KEY	Frequency shift contact keyer; connect across pins P and Q. Pin Q is ground.
CW KEY	Continuous wave keyer; connect across pins R and S. Pin S is ground.
PTT	Push-to-talk device; connect across pins T and U. Pin U is ground.

TABLE 2-1. EXTERNAL CONNECTIONS TO INTERFACE PANEL (CONT)

TRANSMITTER CONTROL JACK J7	
DESIGNATION	FUNCTION/CONNECTION
+24 VDC	+24 vdc output is available between pin A and ground when the transmitter main power is on.
EXTERNAL INTERLOCKS	A closure must be provided to enable transmitter operation; connect external interlock device lines or jumper across pins B and C.
OVERLOAD RESET	A closure must be provided across the COM and NC contacts by an external in-activated switch or jumper; connect jumper or external overload reset switch lines across pins E and G.
AUTO RESET RECYCLE	When the option of Transmitter Automatic Reset Circuit is utilized, the connection of this option is made at pin K.
HV ON	A closure must be provided to enable transmitter high voltage; connect jumper or external high voltage on device lines across pins R and S. Pin S is ground.
XMTR PTT	Push-to-talk device lines which must provide a closure to bias on transmitter; connect external transmitter push-to-talk device or jumper across pins T and U. Pin U is ground.
OUTPUT METER CONTROL	Input line for activating signal outputs to external forward and reflected power meters; provide a ground on pin Y when and if signal outputs are desired for external monitoring of forward and reflected power.

TABLE 2-1. EXTERNAL CONNECTIONS TO INTERFACE PANEL (CONT)

TRANSMITTER REARBACK JACK J3 DESIGNATION	FUNCTION/CONNECTION
+24 VDC	+24 vdc output is available between pin pin A and ground when the transmitter main power is on.
RECEIVER MUTE	Receiver mute terminals provide switch closure in transmitter off condition; connect receiver mute lines across pins B,C and D. C is common; B is normally open; and D is normally closed.
OVERLOAD INDICATOR	Overload indicator terminals are switch closures to ground provided by a transmitter overload condition; connect overload indicating device lines to terminals G and H. G is normally closed; H is normally open.
HV ON INDICATOR	High voltage on indicator lines are for connection in series of a 24 vdc indicating device; connect high voltage indicating device lines across pins P and R. Pin P is (+).
FORWARD POWER REFLECTED POWER	Output terminals for connection of external forward and reflected power meter; connect forward power meter lines across pins a and b; connect reflected power meter lines across pins c and d.

f. RF Monitor Connection. The rf monitor output terminal jack J3 is located on the interface panel and provides a low level rf sample of the exciter output for external monitoring. If external monitoring is desired, connect the monitor line to J3 using the rf connectors UG88/U which are supplied as loose items.

g. External Standard Connection. All output frequencies of the HFTM-1KJ2 transmitter are referenced to the 1 mhz internal standard of the MMX(M)-2 exciter. This internal standard has a stability of 1 part in  $10^8$  per day for ambient change of 15°C. Higher stability is available by use of an external station standard. The external standard input line connection should be made at J4 of the interface panel using the rf connectors UG88/U which are supplied as loose items.

NOTE

When using an external standard set the EXT/INT switch on the rear of the MMX(M)-2 exciter to the EXT position.

h. RF Output Connection. The rf output terminal jack J10 is located on the interface panel. Connect a 50 ohm transmission line to J10, using the rf connector plug UG59/U which is supplied as a loose item. The transmission line must be terminated into a 50 ohm dummy load or antenna.

i. Primary Power Connection. The transmitter leaves the factory wired for 115 vac or 230 vac operation (as per customer requirements). Transmitter power requirements are 115/230 vac, 50/60 hz at approximately 3.75 kw. The power input jack is J2001 which is located in the bottom rear of the equipment cabinet (refer to figure 2-6).

WARNING

BEFORE CONNECTING PRIMARY POWER  
INPUT LINES TO THE TRANSMITTER,  
INSURE THAT THE EXTERNAL PRIMARY  
POWER IS OFF AND TAGGED.

Connect primary power input lines to J2001, using the ac connector plug PL190-NG which is supplied as a loose item.

NOTE

The transmitter cabinet is equipped with two safety interlock switches, S2001 and S2002 (refer to figure 2-6), which must be closed before operating the transmitter. The rear door interlock S2001 is closed when the rear door is mounted and fastened on the equipment cabinet; the high voltage power supply interlock S2002 is closed when the AP152 power supply drawer is mounted and fastened with panel locks in the equipment cabinet.

# LIN AMP TLAM-1K

# INTERFACE

D

C

B

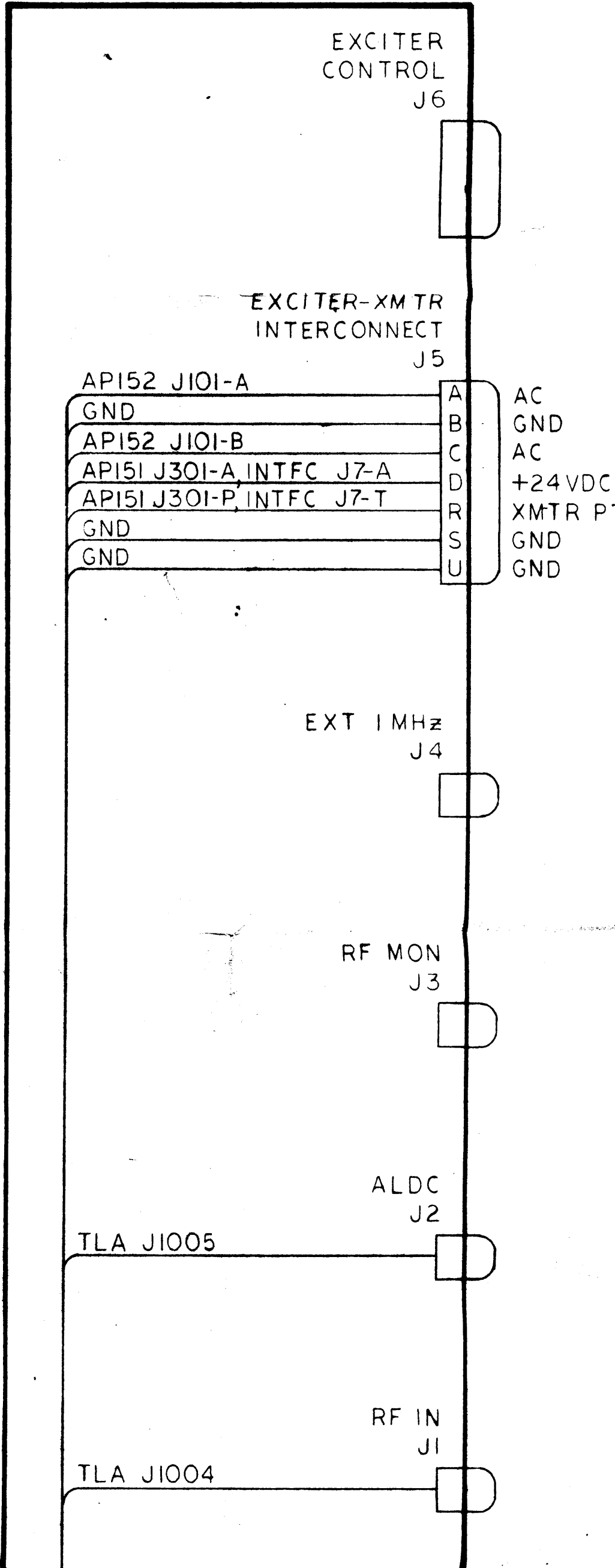
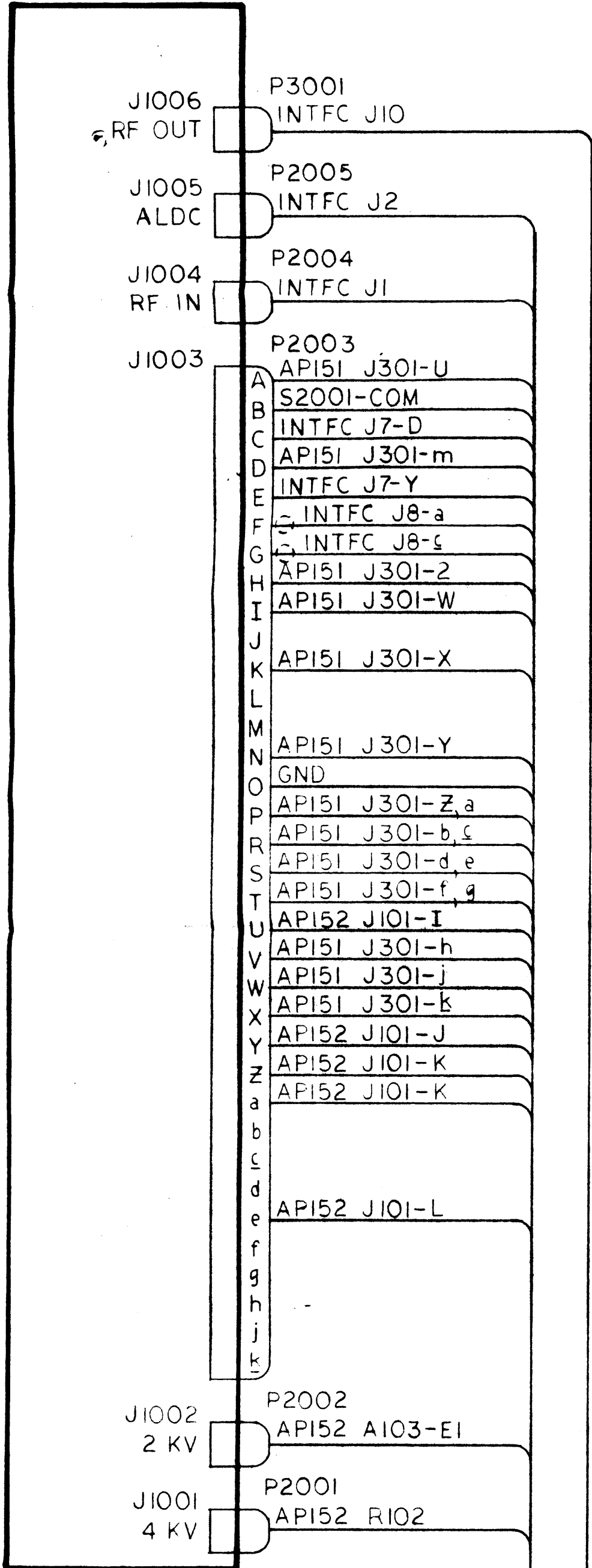

# INTERFACE

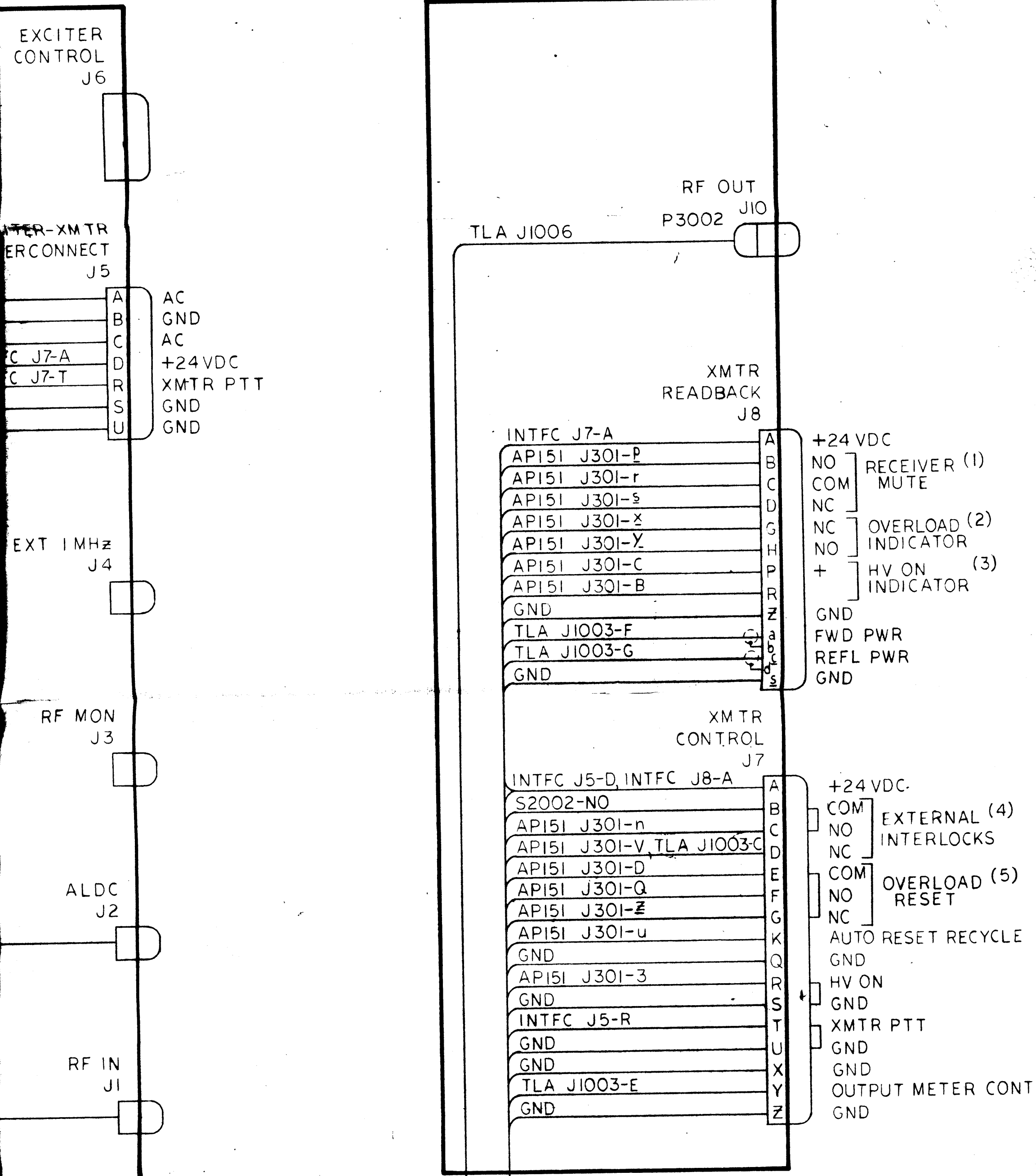

EXCITER CONTROL  
J6

INTER-XMTR  
INTERCONNECT  
J5

A	AC
B	GND
C	AC
D	+24VDC
R	XMTR PTT
S	GND
U	GND

EXT 1MHz  
J4

RF MON  
J3

ALDC  
J2

RF IN  
J1

RF OUT  
P3002 J10

TLA J1006

XMTR  
READBACK  
J8

INTFC J7-A

A	API51 J301-P
B	API51 J301-r
C	API51 J301-s
D	API51 J301-x
E	API51 J301-Y
F	API51 J301-C
G	API51 J301-B
H	GND
P	TLA J1003-F
R	TLA J1003-G
Z	GND

A	+24 VDC
B	NO
C	COM
D	NC
E	NC
F	NO
G	+
H	GND
P	FWD PWR
R	REFL PWR
Z	GND

RECEIVER (1)  
MUTE

OVERLOAD (2)  
INDICATOR

HV ON (3)  
INDICATOR

XMTR  
CONTROL  
J7

INTFC J5-D, INTFC J8-A

A	S2002-NO
B	API51 J301-n
C	API51 J301-V, TLA J1003-C
D	API51 J301-D
E	API51 J301-Q
F	API51 J301-Z
G	API51 J301-u
K	GND
Q	API51 J301-3
R	GND
S	INTFC J5-R
T	GND
U	GND
X	TLA J1003-E
Y	GND
Z	GND

A	+24 VDC
B	COM
C	NO
D	NC
E	COM
F	NO
G	NC
K	AUTO RESET RECYCLE
Q	GND
R	HV ON
S	GND
T	XMTR PTT
U	GND
X	GND
Y	OUTPUT METER CONT
Z	GND

EXTERNAL (4)  
INTERLOCKS

OVERLOAD (5)  
RESET

IF EXTERNAL CONTROLS ARE NOT USED

					REVISIONS
E.M.N.NO	DRAFT	CHKD	ZONE	LTR	DESCRIPTION
	0	.		0	ORIGINAL RELEASE FOR PRODUCTION
21080	GE			A	12001-B USE WAS AP 151 C

LV PWR SPLY  
AP151

HV PWR SPLY  
AP152

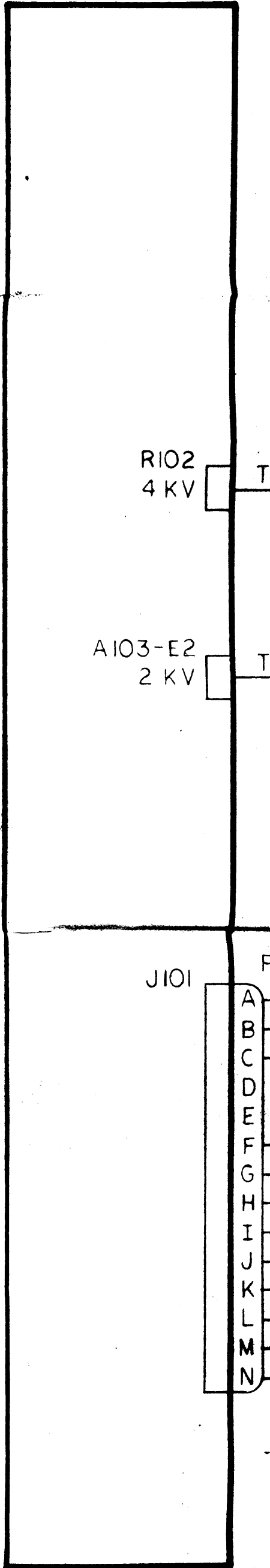
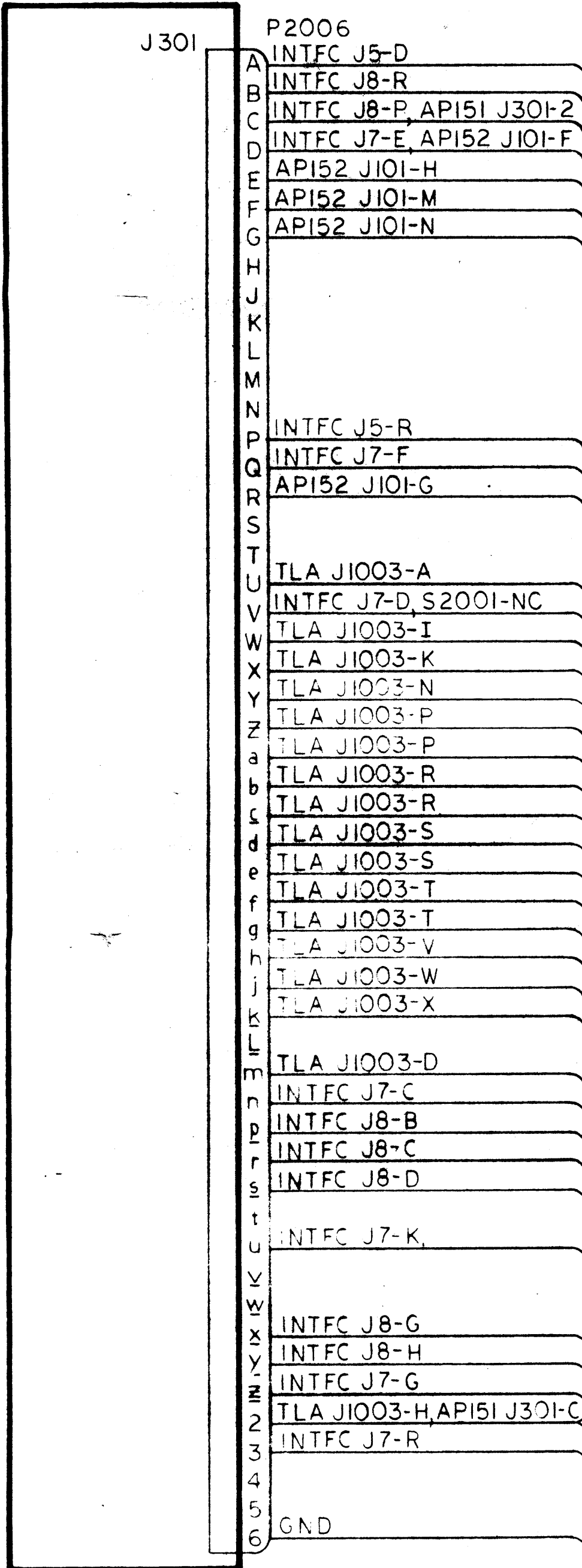

+24 VDC  
 NO ] RECEIVER (1)  
 COM ] MUTE  
 NC ]  
 NC ] OVERLOAD (2)  
 NO ] INDICATOR  
 + ] HV ON (3)  
 ] INDICATOR  
 GND  
 FWD PWR  
 REFL PWR  
 GND

+24 VDC  
 COM ] EXTERNAL (4)  
 NO ] INTERLOCKS  
 NC ]  
 COM ] OVERLOAD (5)  
 NO ] RESET  
 NC ]  
 AUTO RESET RECYCLE  
 GND  
 HV ON  
 GND  
 XMTR PTT  
 GND  
 GND  
 OUTPUT METER CONTROL  
 GND

REVISIONS							
E.M.N.NO	DRAFT	CHKD	ZONE	LTR	DESCRIPTION	DATE	APPROVED
	0	.		0	ORIGINAL RELEASE FOR PRODUCTION	8/21/12	
21080	GE			A	J2001-B I.S.G. WAS AP 151 CHG TO AP152	5/29/13	

HV PWR SPLY  
AP152

LY

301

A	P2006
B	INTFC J5-D
C	INTFC J8-R
D	INTFC J8-P, API51 J301-2
E	INTFC J7-E, API52 J101-F
F	API52 J101-H
G	API52 J101-M
H	API52 J101-N
I	
J	
K	
L	
M	
N	
P	INTFC J5-R
Q	INTFC J7-F
R	API52 J101-G
S	
T	TLA J1003-A
U	INTFC J7-D, S2001-NC
V	TLA J1003-I
W	TLA J1003-K
X	TLA J1003-N
Y	TLA J1003-P
Z	TLA J1003-P
a	TLA J1003-R
b	TLA J1003-R
c	TLA J1003-R
d	TLA J1003-S
e	TLA J1003-S
f	TLA J1003-T
g	TLA J1003-T
h	TLA J1003-V
i	TLA J1003-W
j	TLA J1003-X
k	
l	TLA J1003-D
m	INTFC J7-C
n	INTFC J8-B
p	INTFC J8-C
r	INTFC J8-D
s	
t	INTFC J7-K
u	
v	
w	INTFC J8-G
x	INTFC J8-H
y	INTFC J7-G
z	TLA J1003-H, API51 J301-C
2	INTFC J7-R
3	
4	
5	
6	GND

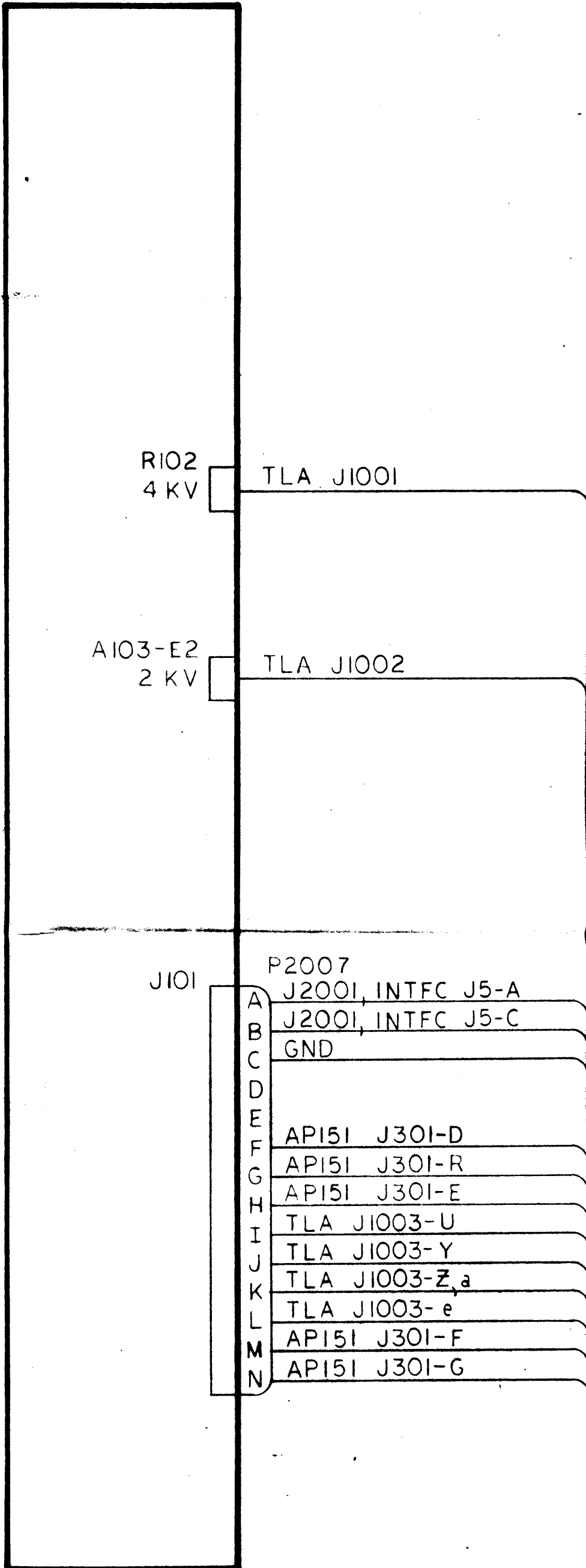

D

C



B  
CK1943  
A



B

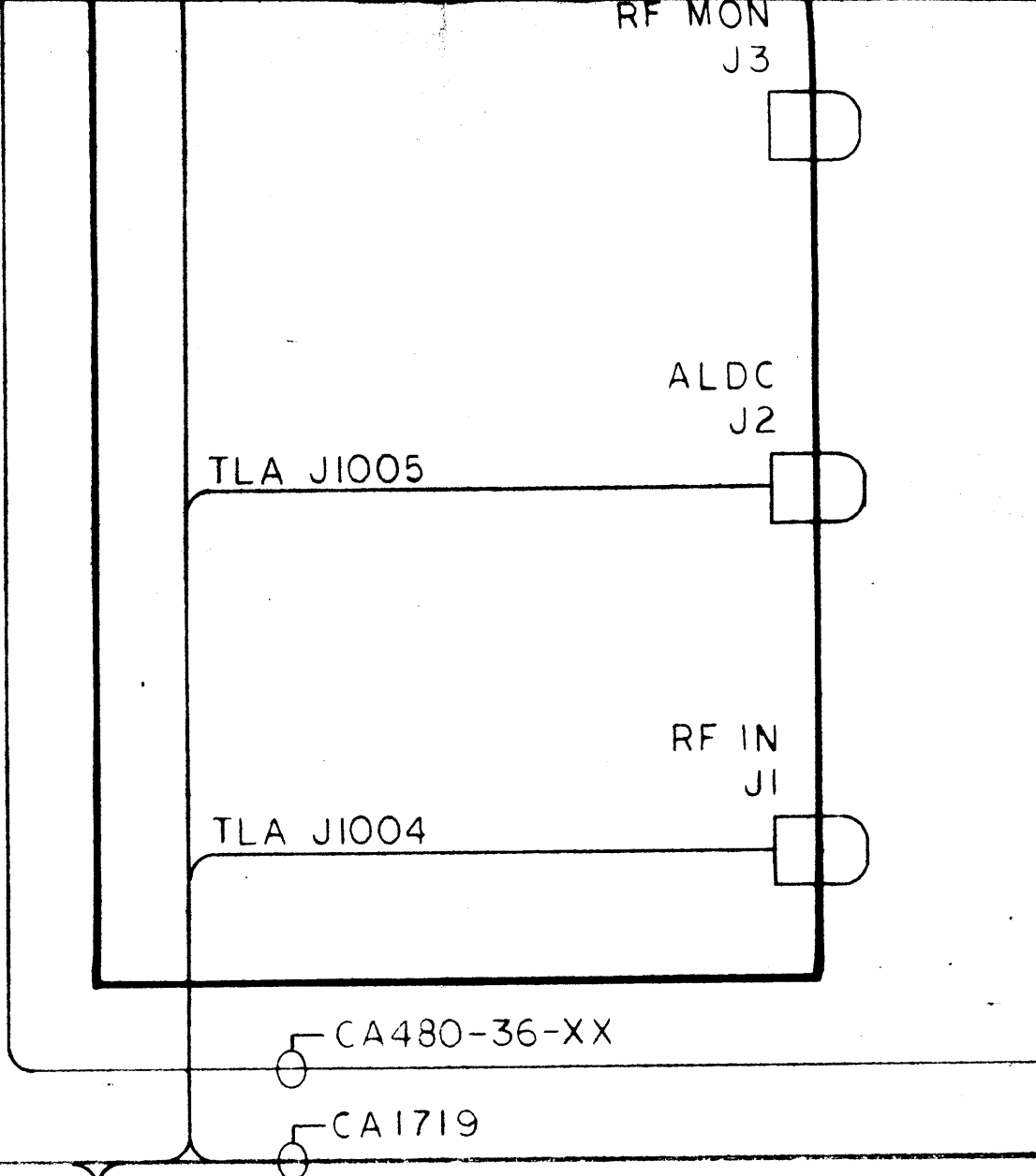
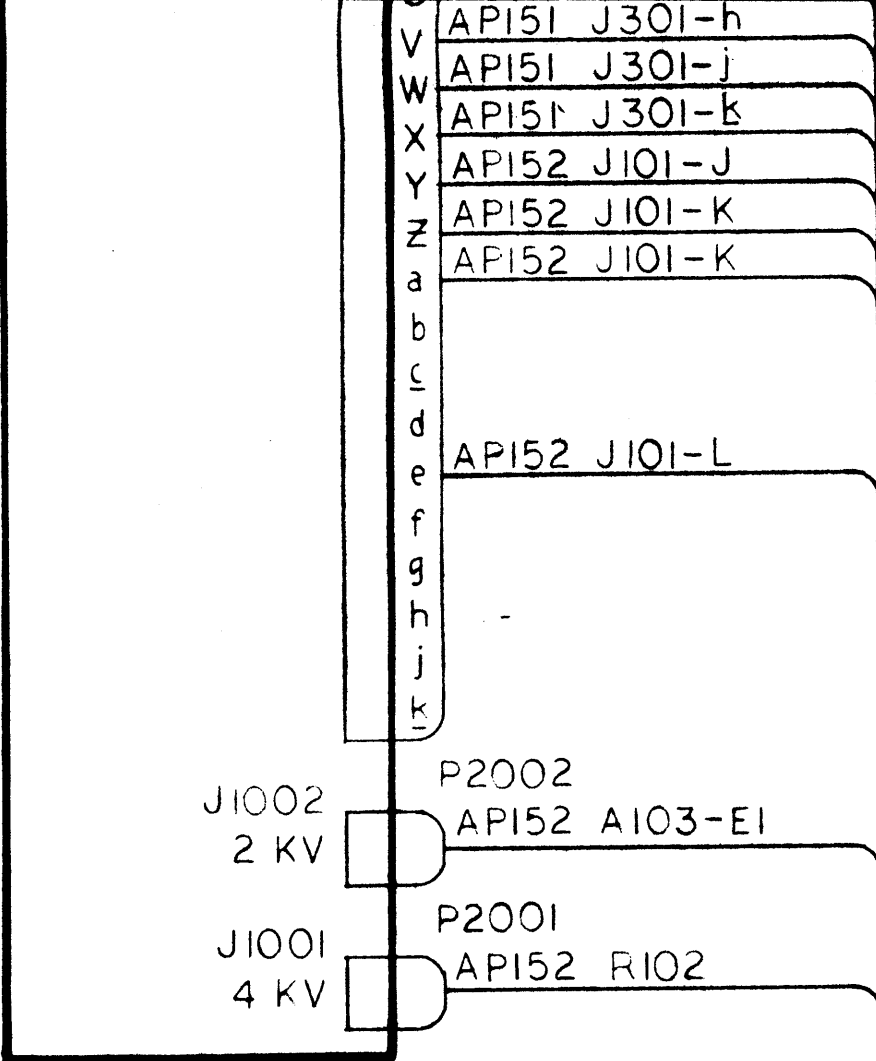

A

- (1). RCVR MUTE TERMINAL DESIGNATIONS ARE SWITCH CLOSURES PROVIDED BY XMTR OFF CONDITION.
- (2). OVLD IND TERMINAL DESIGNATIONS ARE SWITCH CLOSURES TO GND PROVIDED BY XMTR OVERLOADED CONDITION.
- (3). HV ON IND TERMINALS ARE FOR CONNECTION TO A SERIES CONNECTED 24VDC DEVICE.
- (4). INTLK TERMINAL DESIGNATIONS ARE FOR CONNECTION TO AN INACTIVATED SWITCH.
- (5). OVLD RESET TERMINAL DESIGNATIONS ARE FOR CONNECTION TO AN INACTIVATED SWITCH.

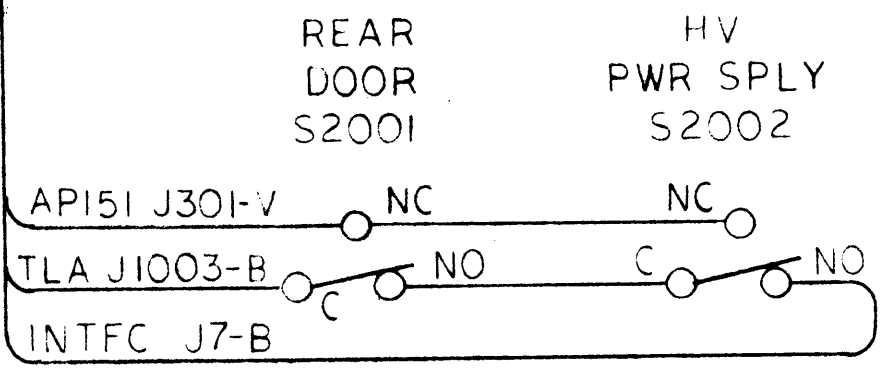

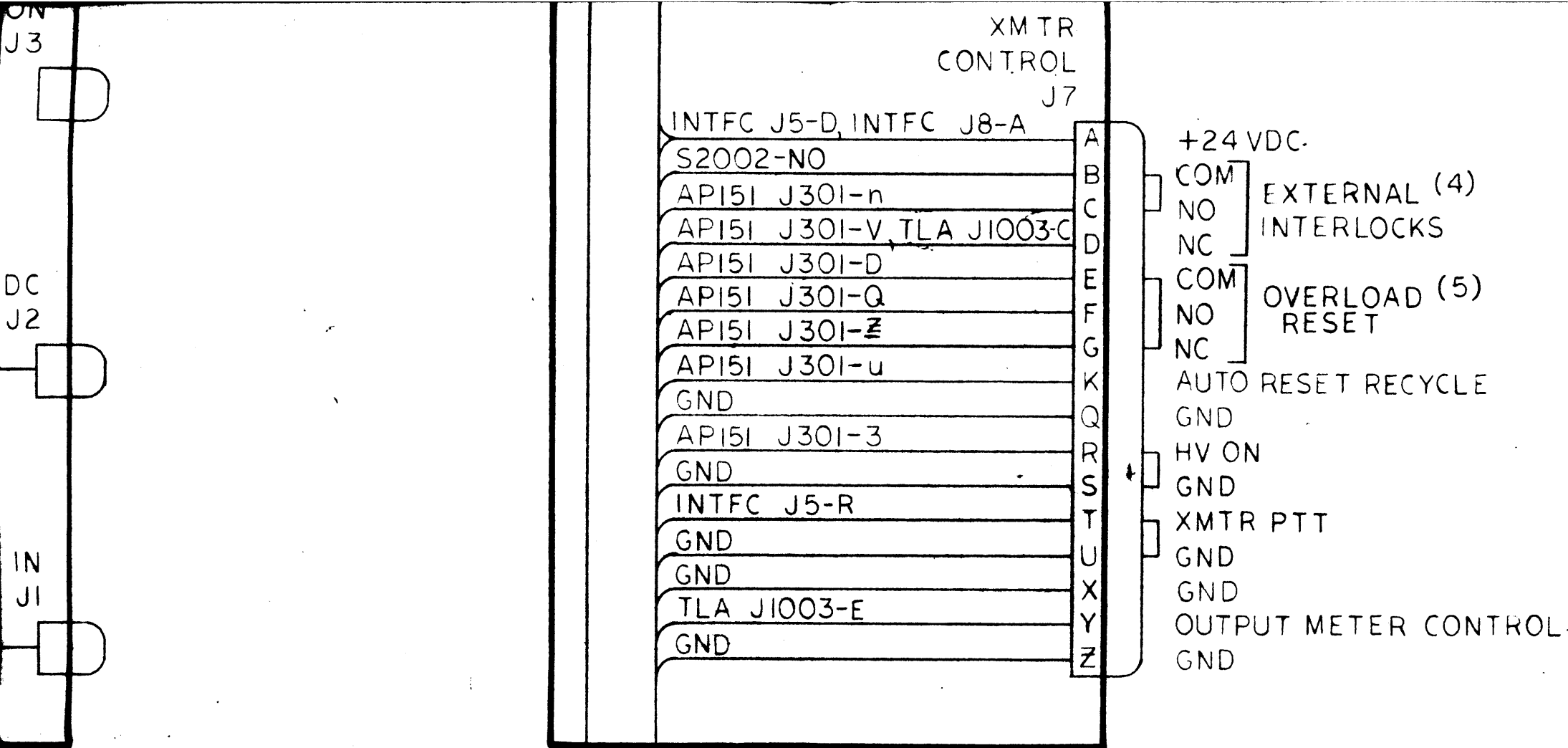

IF EXTERNAL CONTROLS ARE NOT USED  
JUMP J7 PINS AS SHOWN.  
XMTR PTT IS CONTROLLED BY J5-R OR J7-T.

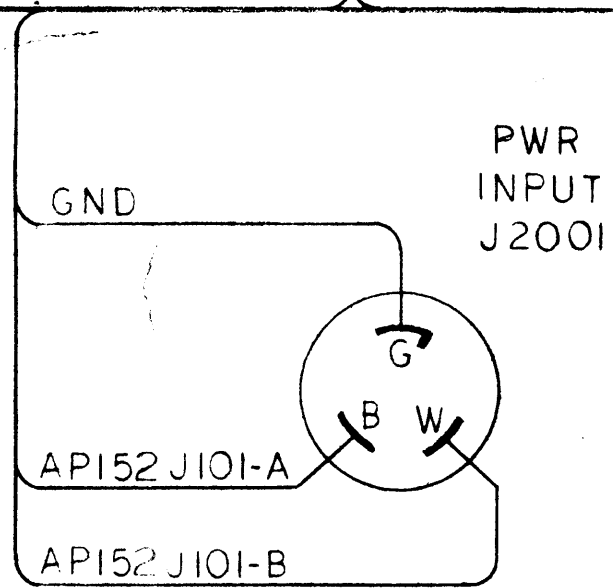
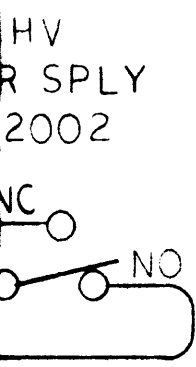

	HFLM-1K/REV A	RAK 139
QTY / UNIT	MODEL USED ON	ASS'Y N
APPLICATION		
	CODE	

**NOTICE TO PERSONS RECEIVING THIS DRAWING**  
**THE TECHNICAL MATERIEL CORPORATION** claims proprietary right in the material disclosed hereon. This drawing is issued in confidence for engineering information only and may not be reproduced or used to manufacture anything shown hereon without permission from **THE TECHNICAL MATERIEL CORPORATION** to the user. This drawing is loaned for mutual assistance and is subject to recall at any time.



DC.  
 EXTERNAL (4)  
 INTERLOCKS  
 OVERLOAD (5)  
 RESET  
 RESET RECYCLE  
 PTT  
 METER CONTROL  
 NOT USED  
 BY J5-R OR J7-T.

h	TLA J1003-V
j	TLA J1003-W
k	TLA J1003-X
l	
m	TLA J1003-D
n	INTFC J7-C
p	INTFC J8-B
r	INTFC J8-C
s	INTFC J8-D
t	
u	INTFC J7-K
v	
w	INTFC J8-G
x	INTFC J8-H
y	INTFC J7-G
z	TLA J1003-H, API51 J301-C
1	INTFC J7-R
2	
3	
4	
5	
6	GND

J101	
A	P2007
B	J2001
C	J2001
D	GND
E	
F	API51
G	API51
H	API51
I	TLA J1
J	TLA J1
K	TLA J1
L	TLA J1
M	API51
N	API51

QTY. REQ.	ITEM	PART NO.	DESCRIPTION
LIST OF MATERIAL			
UNLESS OTHERWISE SPECIFIED DIMENSIONS ARE IN INCHES AND INCLUDE CHEMICALLY APPLIED OR PLATED FINISHES		FINAL APPROVAL <i>JW</i>	DATE 2/14/72
TOLERANCES ON DECIMALS .X ± .05 .XX ± .01 .XXX ± .005 FRACTIONS ± 1/64 ANGLES ± 0° -30'		MECH. DES.	DATE
		ELECT. DES. <i>JW</i>	DATE 2/14/72
MATERIAL		CHECKED	DATE
		DRAWN <i>JW</i>	DATE 1/4/72
FINISH			

MODEL-1K/REV A	RAK 139
MODEL USED ON	ASS'Y NO.
APPLICATION	
CODE	
<small>NO PERSONS RECEIVING THIS DRAWING          CORPORATION claims proprietary right in the material disclosed hereon.          for engineering information only and may not be reproduced or used          without permission from THE TECHNICAL MATERIEL CORPORATION          or mutual assistance and is subject to recall at any time.</small>	

**THE TECHNICAL MATERIEL CORPORATION**  
 MAMARONECK, NEW YORK  
  
 FIGURE 2-4.  
 INTERCONNECT WIRING D  
 (SHEET 1 OF 2)

3

2

h	TLA J1003-V
j	TLA J1003-W
k	TLA J1003-X
l	
m	TLA J1003-D
n	INTFC J7-C
p	INTFC J8-B
r	INTFC J8-C
s	INTFC J8-D
t	
u	INTFC J7-K
v	
w	
x	INTFC J8-G
y	INTFC J8-H
z	INTFC J7-G
1	TLA J1003-H, API51 J301-C
2	INTFC J7-R
3	
4	
5	
6	GND

J101

A	P2007
B	J2001, INTFC J5-A
C	J2001, INTFC J5-C
D	GND
E	
F	API51 J301-D
G	API51 J301-R
H	API51 J301-E
I	TLA J1003-U
J	TLA J1003-Y
K	TLA J1003-Z <sub>a</sub>
L	TLA J1003-e
M	API51 J301-F
N	API51 J301-G

B  
CK1943  
A

QTY. REQ.	ITEM	PART NO.	DESCRIPTION	SYMBOL
<b>LIST OF MATERIAL</b>				
UNLESS OTHERWISE SPECIFIED DIMENSIONS ARE IN INCHES INCLUDE CHEMICALLY APPLIED OR PLATED FINISHES			<b>THE TECHNICAL MATERIEL CORP.</b> MAMARONECK, NEW YORK  <b>FIGURE 2-4.</b> <b>INTERCONNECT WIRING DIAGRAM</b> (SHEET 1 OF 2)	
FINAL APPROVAL <i>JW</i>		DATE 2/14/72		
MECH. DES.		DATE		
ELECT. DES. <i>JW</i>		DATE 3/14/72		
CHECKED		DATE		
DRAWN <i>JW</i>		DATE 1/4/72		
TOLERANCES ON				
DECIMALS	FRACTIONS			
.X ± .05	± 1/64			
.XX ± .01	ANGLES			
.XXX ± .005	± 0° -30'			
MATERIAL				
FINISH				

A

3

2

1

# MMXM-2

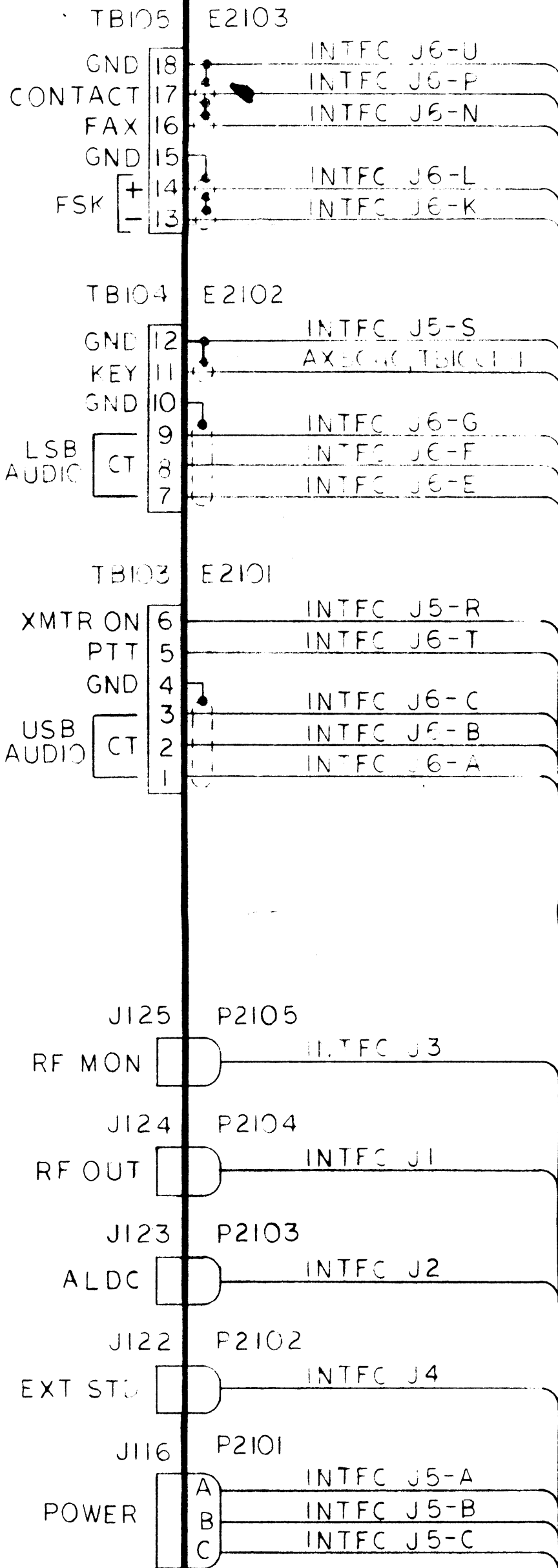

D

C

B



# AX5040

# INTERFACE

- U
- P
- N
- L
- K
- S
- OBJECT 1
- G
- F
- E
- R
- T
- C
- B
- A
- A
- B
- C

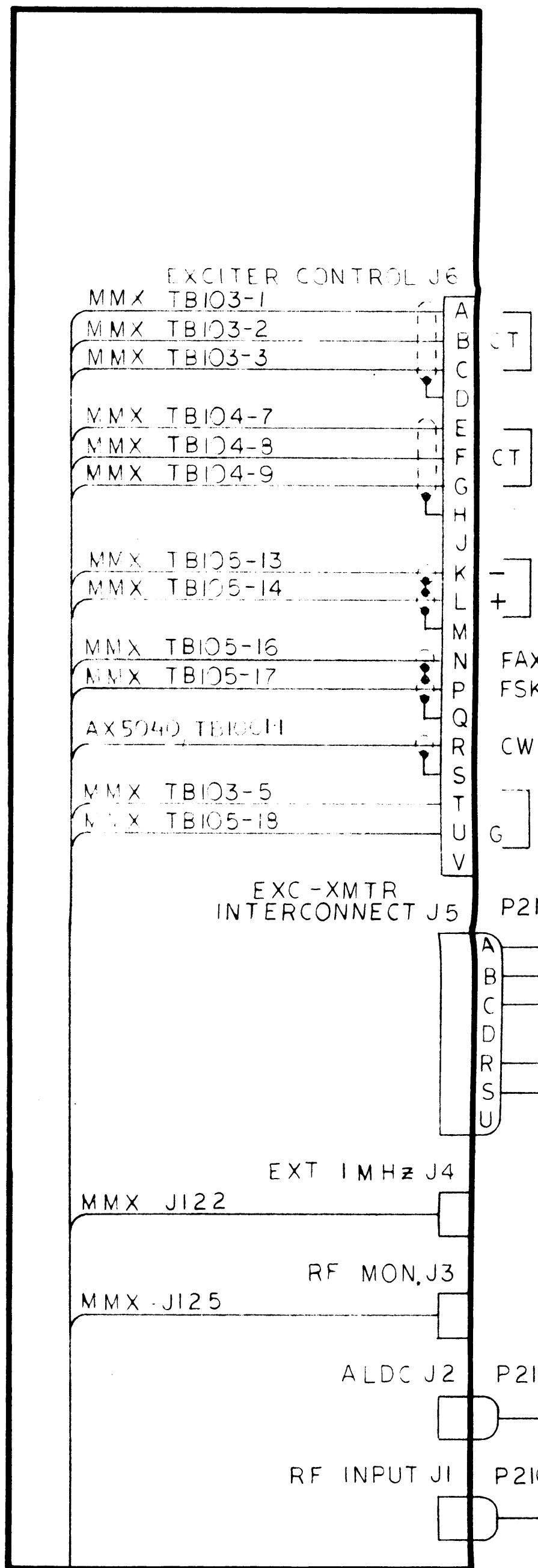
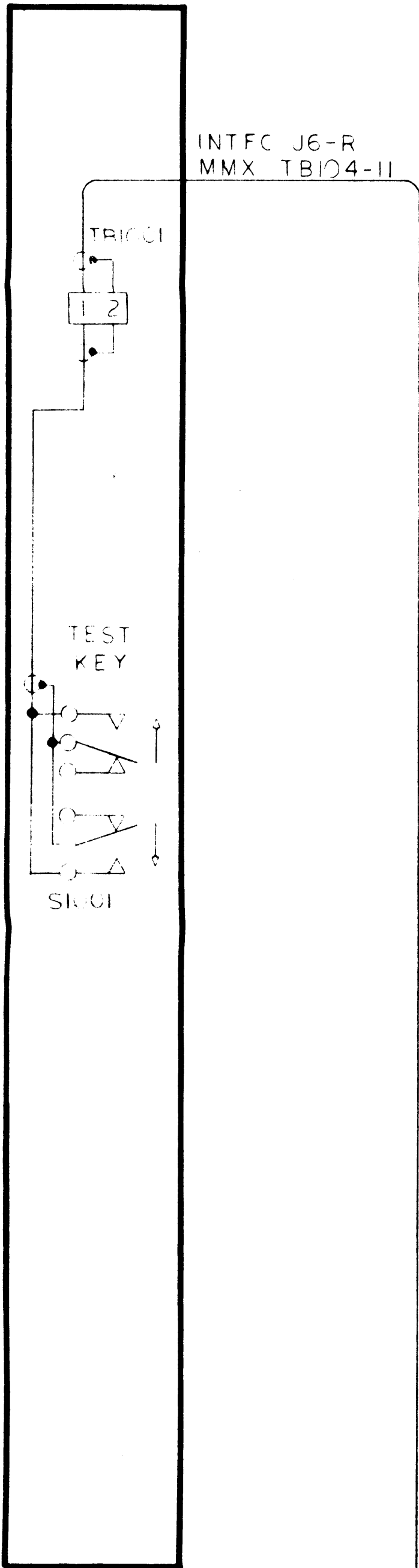

					REVISIONS	
E.M.N.NO	DRAFT	CHKD	ZONE	LTR	DESCRIPTION	
2000	7			A	A/C AS 5-140, ADD CT TO TBIO3-1	

ACE

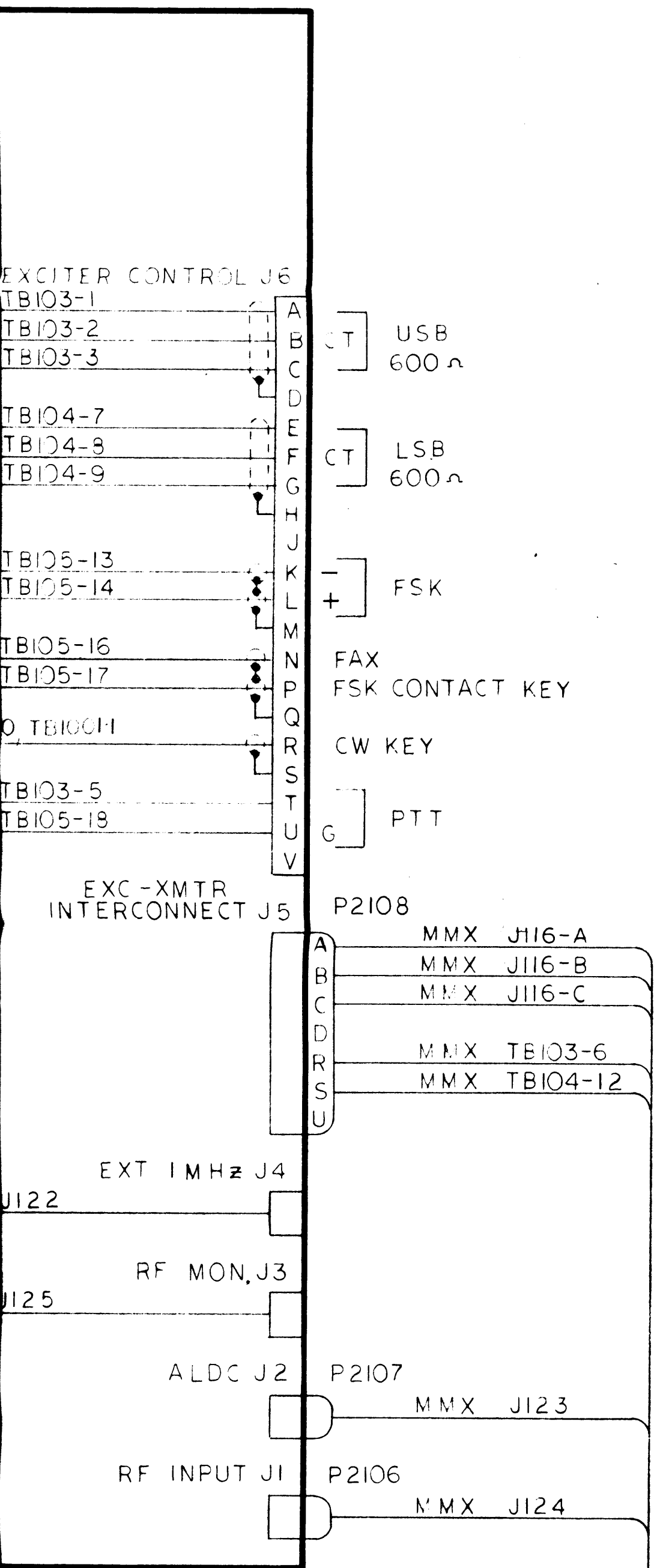

FOR INTERFACE CONNECTIONS SEE CK1943

REVISIONS							
E.M.N.NO	DRAFT	CHKD	ZONE	LTR	DESCRIPTION	DATE	APPROVED

2000	7			A	ADD OF THE INTERFACES	5/19/73	
------	---	--	--	---	-----------------------	---------	--

D

C

FOR INTERFACE CONNECTIONS  
SEE CK1943

KEY

- 116-A
- 116-B
- 116-C
- B103-6
- B104-12
- 123
- 124



B  
CK1977  
A



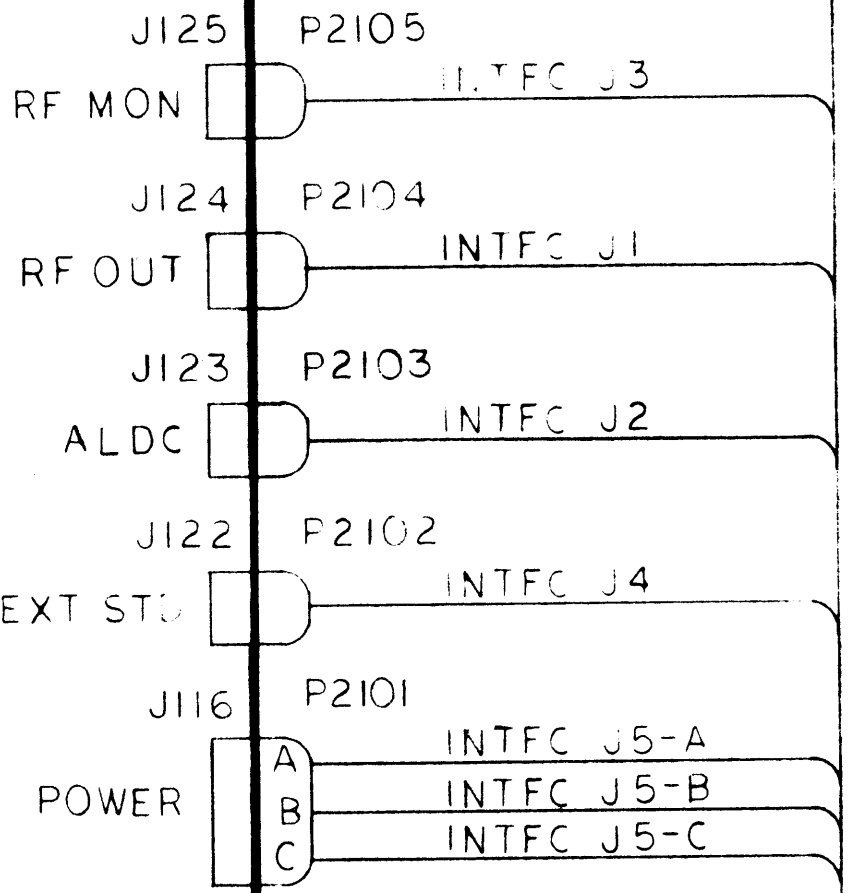

B

A

A  
B  
C  
D  
R  
S  
U

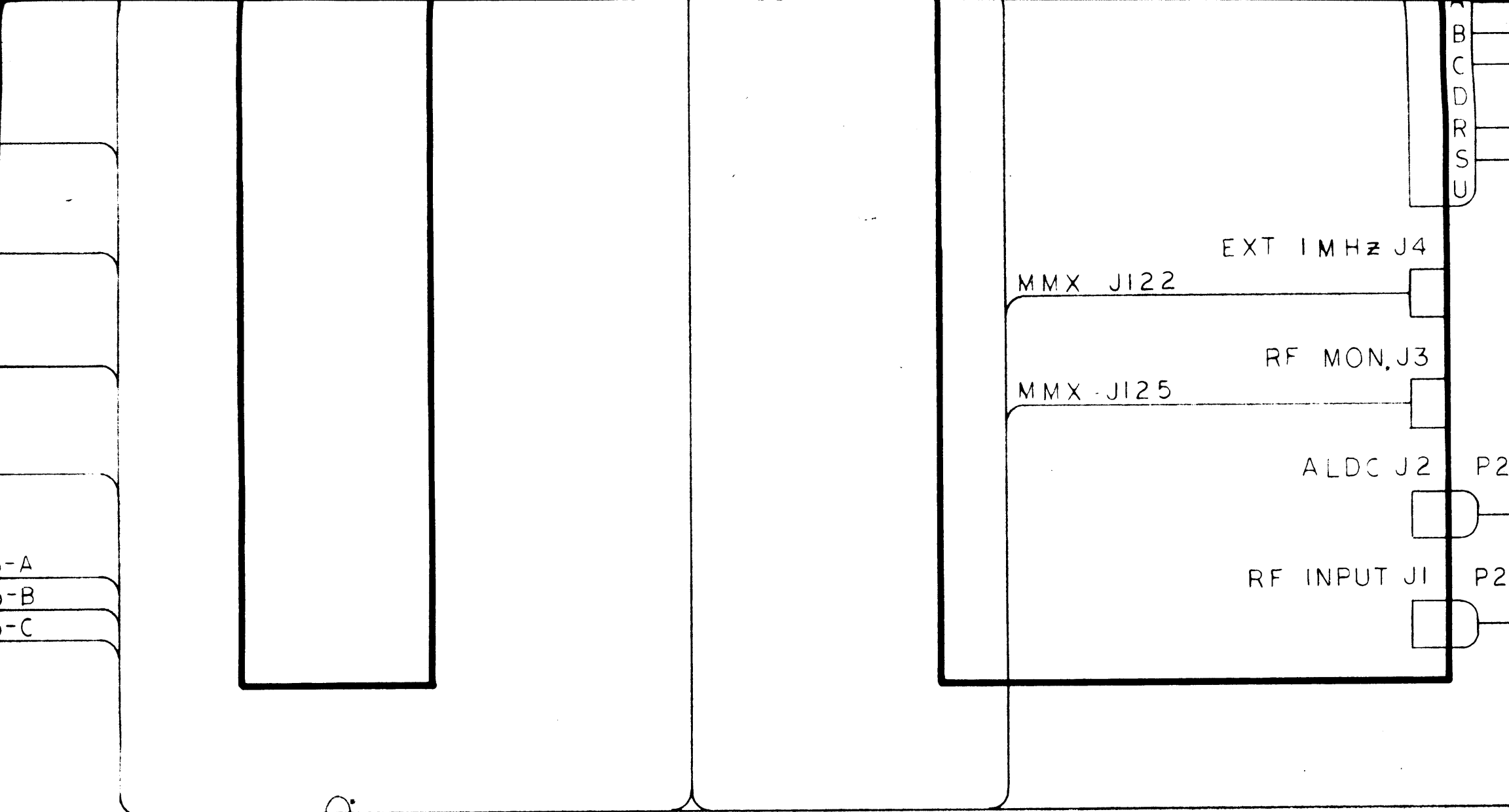

CA1737

	HFTM-1KJ2	
QTY / UNIT	MODEL USED ON	ASSY
APPLICATION		
	CODE	

**NOTICE TO PERSONS RECEIVING THIS DRAWING**  
THE TECHNICAL MATERIEL CORPORATION claims proprietary right in the material disclosed. This drawing is issued in confidence for engineering information only and may not be reproduced to manufacture anything shown hereon without permission from THE TECHNICAL MATERIEL CORPORATION to the user. This drawing is loaned for mutual assistance and is subject to recall at any time.

6

5



4

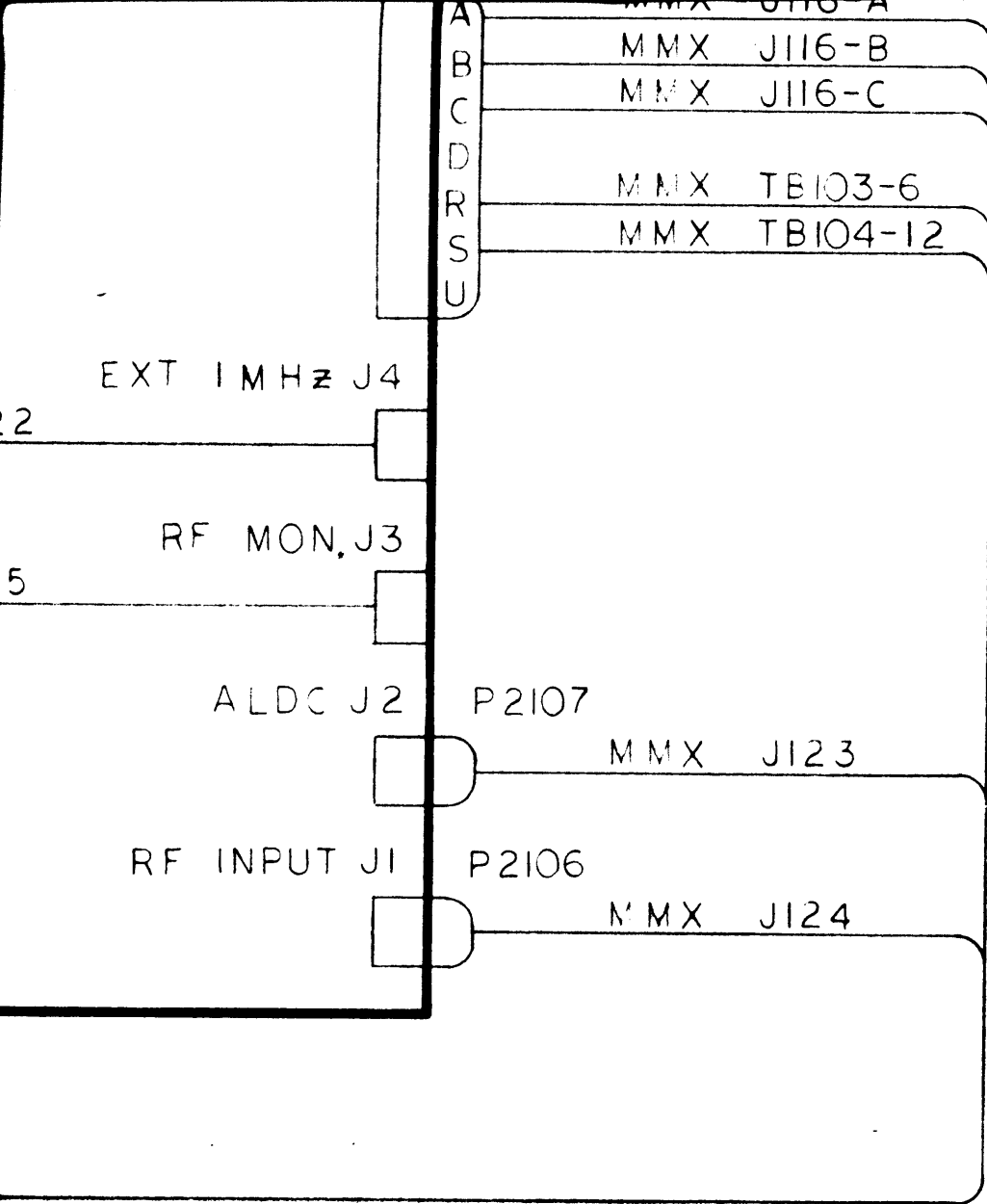

QTY. REQ.		ITEM	PART NO.	DESCRIPTION
LIST OF MATERIAL				
UNLESS OTHERWISE SPECIFIED DIMENSIONS ARE IN INCHES AND INCLUDE CHEMICALLY APPLIED OR PLATED FINISHES		FINAL APPROVAL	DATE	<b>THE TECHNICAL MATERIEL CORPORATION</b> MAMARONECK, N.J.
TOLERANCES ON DECIMALS                      FRACTIONS .X ± .05                              ± 1/64 .XX ± .01                             ANGLES .XXX ± .005                         ± 0° -30'		MECH. DES.	DATE	
		ELECT. DES.	DATE	
MATERIAL  FINISH		CHECKED	DATE	
		DRAWN	DATE	
HFTM-1KJ2				FIGURE 2- INTERCONNECT WIRING (SHEET 2 OF
MODEL USED ON		ASS'Y NO.		
APPLICATION		CODE		
<small>           NOTICE TO PERSONS RECEIVING THIS DRAWING            THE TECHNICAL MATERIEL CORPORATION claims proprietary right in the material disclosed hereon. This drawing is for engineering information only and may not be reproduced or used in any other manner without permission from THE TECHNICAL MATERIEL CORPORATION. THE TECHNICAL MATERIEL CORPORATION is not responsible for mutual assistance and is subject to recall at any time.         </small>				
		3	2	

J116-A  
 J116-B  
 J116-C  
 TB103-6  
 TB104-12  
  
 J123  
 J124

B  
 CK1977  
 A

QTY. REQ.	ITEM	PART NO.	DESCRIPTION	SYMBOL
LIST OF MATERIAL				
UNLESS OTHERWISE SPECIFIED DIMENSIONS ARE IN INCHES INCLUDE CHEMICALLY APPLIED OR PLATED FINISHES		FINAL APPROVAL <i>[Signature]</i>	DATE 13 FEB 73	<b>THE TECHNICAL MATERIEL CORP.</b> MAMARONECK, NEW YORK  FIGURE 2-4. INTERCONNECT WIRING DIAGRAM (SHEET 2 OF 2)  PAGE 2-10
TOLERANCES ON		MECH. DES.	DATE	
DECIMALS	FRACTIONS	ELECT. DES. <i>[Signature]</i>	DATE 13 FEB 73	
X ± .05	± 1/64	CHECKED	DATE	
X ± .01	ANGLES	DRAWN <i>[Signature]</i>	DATE 12 FEB 73	
X ± .005	± 0° -30'			
ERIAL				
SH				

A

3
2
1

TABLE 2-2. CONNECTORS SUPPLIED AS LOOSE ITEMS

TRC PART NUMBER	FUNCTION
UG88/U	Connection to interface panel jacks J3 and J4
MS3106E24-28S	Connection to interface panel jack J6
MS3106E24-28P	Connection to interface panel jack J7
MS3106E28-21P	Connection to interface panel jack J8
UG59/U	Connection to interface panel jack J10
PL190-NG	Connection to ac power input jack J2001
PJ055B	Connection to excitor KEY input jack
PJ068B	Connection to excitor MIKE input jack

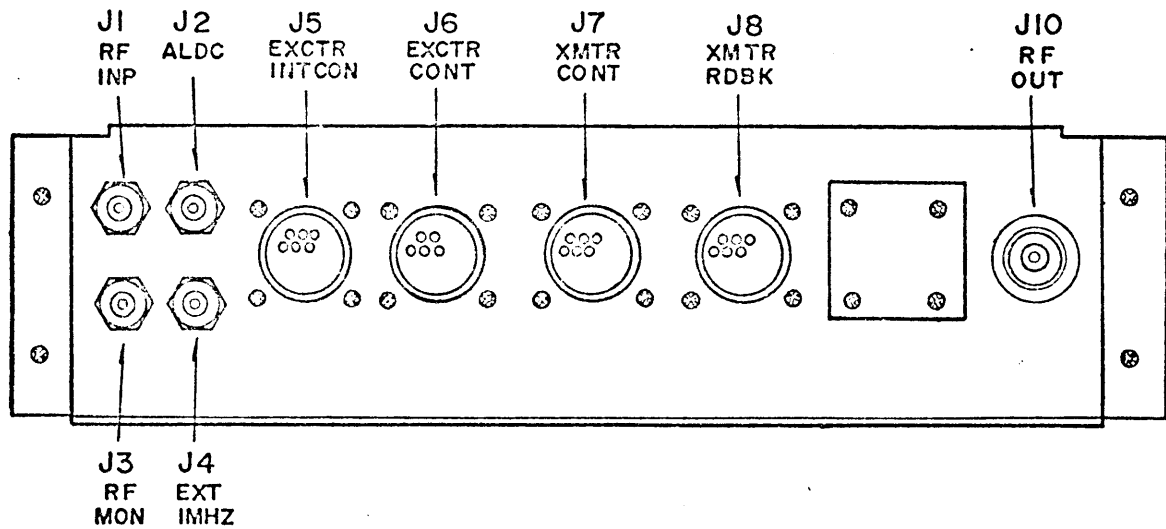

Figure 2-5. Interface Panel

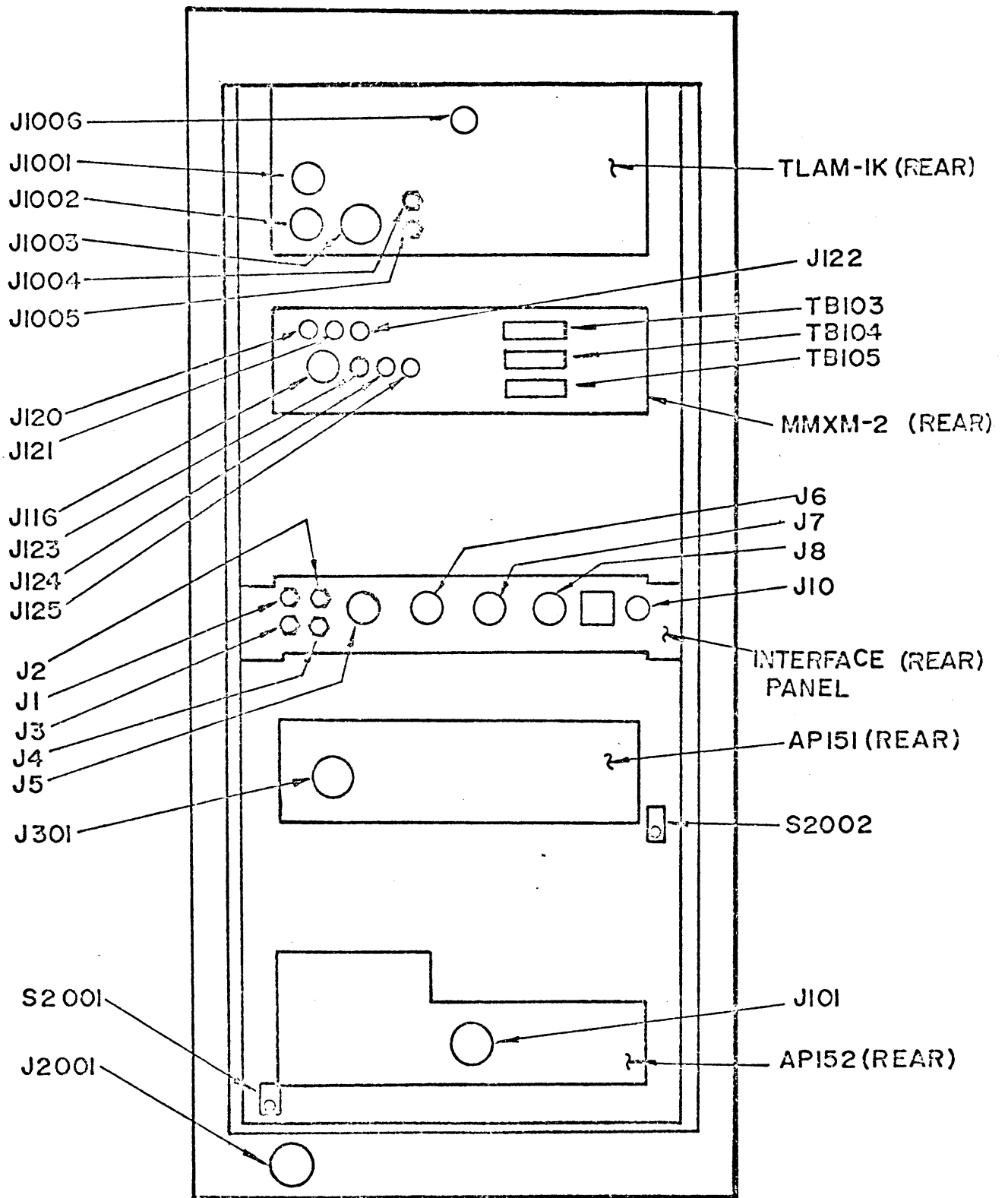

Figure 2-6. HFTM-1KJ2 Component Locations, Rear View

SECTION 3  
OPERATOR'S SECTION

3-1. SCOPE.

This section gives detailed operating instructions for the HFTM-1KJ2 transmitter.

3-2. GENERAL.

Although an extensive interlock and overload system is designed into the HFTM-1KJ2 transmitter, a single incorrect control setting might still overload certain components, inviting early failure and consequently transmitter "down-time", not to mention improper and illegal emission.

Prior to operation of the transmitter, the operator should become thoroughly familiar with the location and function of all transmitter controls and indicators. When operating the transmitter, a definite operating sequence (as outlined by the operating instructions) should be strictly followed; the operator should establish a procedural pattern, thus ensuring consistent operation.

3-3. CONSIDERATIONS IN TRANSMITTER TUNING.

a. GENERAL. Before the HFTM-1KJ2 is tuned for any specified mode of operation, it should be initially tuned and loaded on a carrier frequency.

This procedure should be followed even if suppressed carrier operation is desired. After the transmitter is tuned to carrier frequency, either or both sidebands are generated by applying the proper modulating signals required by the particular mode of operation. The carrier level may then be re-inserted or bypassed, as desired.

b. CARRIER FREQUENCY VERSUS ASSIGNED FREQUENCY A brief description of "carrier" versus "assigned" frequency is presented at this point since these may be significantly different when operating in certain modes and will affect the choice of frequency to be selected in the exciter. "Carrier" frequency may be defined as that position in the rf spectrum reserved for the "carrier" whether the carrier is present or not. The "assigned" frequency is a reference frequency designed to identify or reserve a given portion of the rf spectrum. Most government agencies define the "assigned" frequency as the "center of a frequency band assigned to a station". The "assigned" frequency and the "carrier" frequency may or may not be the same. In practice, the assigned frequency is frequently suffixed by the carrier frequency in parenthesis for clarification.

Example 1 For an upper sideband transmission, with the carrier completely suppressed and with a total rf bandpass extending from 300 hz above  $F_c$  to 3 khz, the assigned frequency is 1650 hz above the non-existent carrier frequency.

Example 2 For an independent sideband (ISB) transmission, with audio intelligence covering 350-7500 hertz per sideband, with or without carrier suppression, the assigned frequency and the carrier frequency are one and the same, both occupying the center of the transmitted spectrum.

c. PEAK ENVELOPE POWER VERSUS AVERAGE POWER INDICATION. A common misapprehension continues to exist over the ratio between average and PEP in high power transmitters, particularly when multichannel (multitone) transmissions are used. Bear in mind that the Peak Envelope Power (PEP) during modulation can be many times that of the Average Power indicated on the PA OUTPUT meter. Thus the transmitter Average Power must be reduced sufficiently to avoid a serious peak overload to the transmitter, with consequent "flat topping" and possible damage.

When two tones of equal amplitude are applied to a SSB system, the ratio of PEP to Average Power is  $.405 \times \text{PEP}$ . This relationship is valid for two tones only. When the HFTM-1KJ2's OUTPUT meter indicates 500 watts with two tones of equal amplitude applied to the transmitter, peak envelope power (PEP) will be 1000 watts under that condition only. A graphical representation of peak and average power ratio as a function of the number of tones is shown in figure 3-1.

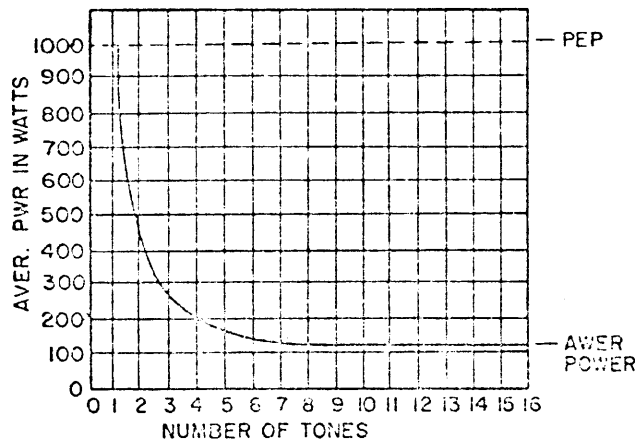

Figure 3-1. Ratio Average Power and PEP as a Function of Tones

#### 3-4. OPERATING CONTROLS AND INDICATORS.

Control and indicator chart, table 3-1 has been prepared in conjunction with control and indicator location drawing, figure 3-2, to assist in the location and operation of all controls and indicators required for tuning and operating the HFTM-1KJ2 transmitter.



TABLE 3-1. CONTROLS AND INDICATORS

ITEM NO.	PANEL DESIGNATION	FUNCTION
1	MAIN POWER circuit breaker	When placed in the ON position, applies ac power to the transmitter.
2	MAIN POWER indicator lamp	When illuminated, indicates that ac power is applied to the transmitter
3	FILA indicator fuse	Protective fuse for filament and bias transformer; when illuminated, indicates open fuse.
4	BLOWER indicator fuse	Protective fuse for blower; when illuminated, indicates open fuse.
5	LV indicator fuse	Protective fuse for primary ac input to low voltage transformer; when illuminated indicates open fuse.
6	SCREEN and PLATE circuit breakers	In ON position, applies screen and plate voltages to the rf amplifier tubes.
7	INTERLOCKS indicator	When illuminated, indicates that all interlocks are closed and the interlock circuit is complete.
8	TEST KEY switch	Front panel keying device for exciter testing and key down operation; when in the up position, test key locks.
9	10KHZ, 1MHZ, 100KHZ, 10KHZ, 1KHZ, 100HZ selector switches	Frequency selector switches used to set desired operating frequency
10	KEY jack	Front panel key jack for dry contact keyer connection in CW mode of operation.
11	MIKE jack	Front panel mike jack for 47,000 ohm impedance microphone input.
12	LSB MIKE/LINE control	Audio gain control for adjustment of lower sideband mike or line audio inputs.

TABLE 3-1. CONTROLS AND INDICATORS (CONT)

ITEM NO.	PANEL DESIGNATION	FUNCTION
13	METER selector switch	Selects exciter circuit to be monitored on MONITOR meter: Q1, Q2, Q3 collector currents, LSB or USB audio levels, and CARRIER or RF output levels.
14	RF OUTPUT control	Adjusts the level of rf output signal from the exciter.
15	AC indicator fuse	Protective ac line fuse; when illuminated, indicates open fuse.
16	RF GAIN control	Adjusts the level of transmitter power output.
17	PLATE meter switch (marked 2nd AMP, IPA and 1st AMP)	Selects plate current circuit to be monitored on the PLATE current meter.
18	TUNE control	Adjusts the variable tune capacitor.
19	PLATE meter	Indicates plate currents of the 1st rf amplifier, 2nd rf amplifier and IPA as selected by the meter switch.
20	BAND selector switch	Selects frequency band of operation from 1.5 mhz to 30 mhz (1.5 - 2.0, 2.0 - 2.6, 2.6 - 3.0, 3-5, 5-8, 8-12, 12-16, 16-24, 24-30).
21	OUTPUT meter	Indicates output and reflected powers in kilowatts.
22	LOAD control	Adjusts the variable load capacitor.
23	AIDC control	Adjusts the level of automatic load and drive control feedback voltage from the amplifier to the exciter.
24	REFL pushbutton switch	When pressed, activates OUTPUT meter to monitor reflected power; otherwise, the OUTPUT meter monitors output power.
25	MONITOR meter	Monitors exciter circuits selected by METER switch.

TABLE 3-1. CONTROLS AND INDICATORS (CONT)

ITEM NO.	PANEL DESIGNATION	FUNCTION
26	STANDBY indicator	When illuminated, indicates that ac power is applied to the exciter crystal ovens and power supplies and that dc potentials are not applied to the exciter circuitry; illuminated when the ON/STANDBY switch is in the STANDBY position.
27	POWER indicator	When illuminated, indicates that dc potentials are applied to the exciter circuitry; illuminated when the ON/STANDBY switch is in the ON position.
28	EXCITER ON/PTT switch	In EXCITER/ON position energizes exciter and transmitter PTT relays; in PTT position routes control of PTT relays to the MIKE input jack.
29	ON/STANDBY switch	Controls application of dc potentials to exciter circuitry; in the ON position dc potentials are applied; in the STANDBY position dc potentials are removed.
30	MODE selector switch	Selects the mode of transmitter operation: i.e. AM (amplitude modulation), USB (upper sideband), LSB (lower sideband), ISB (independent sideband), CW (continuous wave), FSK (frequency shift keying), or FAX (facsimile).
31	CARR SUPPR selector switch	Selects degree of carrier suppression: i.e. 0 (carrier fully inserted), 6 (suppressed -6 db), 16 (suppressed -16 db), or FULL (carrier fully suppressed, greater than -55 db).
32	AC indicator fuse	Protective ac line fuse; when illuminated, indicates open fuse.
33	USB MIKE/LINE control	Audio gain control for adjustment of upper sideband mike or line audio inputs.

TABLE 3-1. CONTROLS AND INDICATORS (CONT)

ITEM NO.	PANEL DESIGNATION	FUNCTION
34	ALARM indicator	Audible alarm which sounds to indicate the failure and loss of high voltage.
35	HIGH VOLTAGE indicator switch	A pushbutton switch which controls the application of high voltage to the rf amplifier; illuminates to indicate that high voltage is applied.
36	BIAS indicator fuse	Protective fuse in dc return of bias supply; when illuminated, indicates open fuse.
37	DC indicator fuse	Protective fuse for 24 vdc supply; when illuminated, indicates open fuse.
38	CONTROL indicator fuse	Protective fuse for low voltage and filament transformer; when illuminated, indicates open fuse.
39	ALARM ON/off switch	Switch to control the alarm circuitry; in the off position the alarm circuitry is inoperative; in the ON position the alarm sounds when high voltage fails or is removed from the rf amplifier.
40	HIGH VOLTAGE indicator	When illuminated, indicates that high voltage is applied to the rf amplifier.

3-5. OPERATING PROCEDURES.

a. Introduction. The operation of the HFTM-1KJ2 transmitter is detailed in the paragraphs which follow. Paragraph 3-5b. Preliminary Operation gives detailed instructions for control settings prior to operation, for application of main power and high voltage, and for bias checks and adjustments. Paragraph 3-5c. General Operation gives detailed instructions for transmitter tuning on carrier and for transmitter operation in the various intelligence modes.

CAUTION

Do not attempt to operate transmitter unless it has been determined that the rf output connection of the transmitter is properly terminated in an antenna or dummy load.

b. Preliminary Operation. Prior to initial application of power to the transmitter, the HFTM-1KJ2 controls should be set as outlined in Table 3-2

TABLE 3-2. STARTING CONTROL SETTINGS

CONTROL DESIGNATION	LOCATION	SETTING
(1) Primary Power circuit breaker	external to the transmitter	OFF position
(2) MAIN POWER circuit breaker (1)	AP152 front panel	OFF (down) position
(3) SCREEN and PLATE circuit breakers (6)	AP151 front panel	OFF (down) position
(4) ALARM ON switch (39)	AP151 front panel	off (down) position
(5) PA, 1st AMP and 2nd AMP bias controls	within AP151 drawer	fully clockwise (maximum bias)
(6) TEST KEY switch (8)	AX5040 panel	neutral position
(7) RF OUTPUT control (14)	MMX(M)-2 front panel	fully counterclockwise
(8) LSB MIKE/LINE (12) and USB MIKE/LINE (33) controls	MMX(M)-2 front panel	mid-range (0)
(9) ON/STANDBY switch (29)	MMX(M)-2 front panel	STANDBY position
(10) EXCITER ON/PTT switch (28)	MMX(M)-2 front panel	EXCITER ON position
(11) RF GAIN control (16)	TLAM-1K front panel	fully counterclockwise
(12) ALDC control (23)	TLAM-1K front panel	fully counterclockwise
(13) LOAD control (22)	TLAM-1K front panel	counterclockwise to first indicator line on left
(14) Plate current overload adjust screw	TLAM-1K front panel below PLATE meter	screw adjusted so that overload indicator (red) on PLATE meter is set at 800 ma.

Once the transmitter controls have been set to their starting control settings, the HFTM-1KJ2 is ready for initial application of main power and high voltage and for bias adjustments. These procedures are detailed in Table 3-3.

TABLE 3-3. PRELIMINARY OPERATING PROCEDURE

STEP	OPERATION	NORMAL INDICATION
1	Set Primary Power circuit breaker to the ON position.	Primary Power indicator (if any) external to transmitter illuminates.
2	Set MAIN POWER circuit breaker (1) to the ON position.	PA blower operates and MAIN POWER indicator (2) on AP152 illuminates INTERLOCKS indicator (7) on the AP151 illuminates (all safety interlocks must be closed and the time delay cycle must be completed).
3	Set SCREEN and PLATE circuit breakers (6) to ON positions.	No indications.
4	Unfasten the panel locks on the AP151 and pull drawer out to expose the PA, 1st AMP and 2nd AMP BIAS controls.	No indications.
5	Press the HIGH VOLTAGE switch/indicator (35) on the AP151 to illuminate indicator (it may be necessary to press the HIGH VOLTAGE switch twice).	HIGH VOLTAGE indicators (35) and (40) on the AP151 and AP152 must illuminate.
6	Hold the PLATE meter switch (17) on the TLAM-1K in the down (1st AMP) position, and adjust the 1st AMP BIAS control in the AP151 drawer for 60 to 70 ma of quiescent current.	PLATE meter (19) on TLAM-1K indicates 60 to 70 ma.
7	Hold the PLATE meter switch (17) on the TLAM-1K in the up (2nd AMP) position, and adjust the 2nd AMP BIAS control in the AP151 drawer for 220 to 240 ma of quiescent current.	PLATE meter (19) on TLAM-1K indicates 220 to 240 ma.
8	With the PLATE meter switch (17) on the TLAM-1K in its neutral (IPA) position, adjust the PA BIAS control in the AP151 drawer for 210 to 230 ma quiescent current.	PLATE meter (19) on TLAM-1K indicates 210 to 230 ma.

c. General Operation. Prior to operating the HFTM-1KJ2 transmitter in any of its intelligence modes, the transmitter must be initially tuned on carrier. Table 3-4 details the procedure for transmitter tuning on carrier; table 3-5 details typical control settings to be used as a guide for tuning.

TABLE 3-4. TRANSMITTER TUNING PROCEDURE  
(CARRIER ONLY)

STEP	OPERATION	NORMAL INDICATION
1	Perform steps 1 thru 5 in Table 3-3 to apply main power and high voltage to the transmitter.	Indications are the same as Table 3-3.
2	Hold the PLATE meter switch (17) on the TLAM-1K in the down (1st AMP) position.	PLATE meter (19) on the TLAM-1K indicates 60 to 70 ma (if not, perform step 6 in Table 3-3).
3	Hold the PLATE meter switch (17) on the TLAM-1K in the up (2nd AMP) position.	PLATE meter (19) on the TLAM-1K indicates 220 to 240 ma (if not, perform step 7 in Table 3-3).
4	With the PLATE meter switch (17) on the TLAM-1K in its neutral position, observe the PLATE meter (19) on the TLAM-1K.	PLATE meter (19) on the TLAM-1K indicates 210 to 230 ma (if not, perform step 8 in Table 3-3).
5	Set the frequency selector switches (9) on the MMX(M)-2 to the desired carrier frequency (refer to paragraph 3-3 to determine carrier frequency for proper operation within the assigned frequency spectrum).	No indications.
6	Set the BAND selector switch (20) on the TLAM-1K to a band which covers the desired operating frequency.	Window above the BAND selector switch (20) indicates desired frequency band.
7	Set controls on the MMX(M)-2 as follows: METER switch (13) to RF position, CARR SUPPR switch (31) to 0 position, ON/STANDBY switch (29) to ON position, EXCITER ON/PTT switch (28) to EXCITER ON position, and MODE switch (30) to CW position.	The POWER indicator (27) on the MMX(M)-2 illuminates.

TABLE 3-4. TRANSMITTER TUNING PROCEDURE (CONT)  
(CARRIER ONLY)

STEP	OPERATION	NORMAL INDICATION
8	Set the TEST KEY switch (8) on the AX5040 to the up (locked) position, and adjust the RF OUTPUT control (14) on the MMX(M)-2 for an output of 100 milliwatts.	MONITOR meter (25) on the MMX(M)-2 reads approximately 2.
9	Adjust RF GAIN CONTROL (16) on the TLAM-1K clockwise slightly to cause an increase in PA plate current.	PLATE meter (19) on the TLAM-1K indicates an increase in PA plate current (not to exceed 300 ma).
10	Adjust TUNE control (18) on the TLAM-1K for a noticeable resonant dip in PA plate current.	PLATE meter (19) on the TLAM-1K indicates a resonant dip and OUTPUT meter (21) on the TLAM-1K indicates simultaneously an increase in output power.
11	Adjust the LOAD control (22) on the TLAM-1K as required to produce maximum output power.	The OUTPUT meter (21) on the TLAM-1K indicates a further increase in output power during loading process.
12	Readjust the TUNE control (18) on the TLAM-1K to insure that the transmitter is at resonance. Repeat steps 10 and 11 as necessary.	The OUTPUT meter (21) on the TLAM-1K indicates highest value when the transmitter is properly tuned into an antenna or dummy load.
13	Rotate the RF GAIN control (16) on the TLAM-1K clockwise to increase output power to the desired level. (Refer to the Maintenance Section of the HFIM-1K Technical Manual for AIDC adjustment.)	The OUTPUT meter (21) on the TLAM-1K indicates the average power output level.
14	Set the TEST KEY switch (8) on the AX5040 to its center or neutral position.	The OUTPUT meter (21) on the TLAM-1K indicates zero.



TABLE 3-5. TYPICAL TRANSMITTER TUNING CHART

FREQUENCY (MHz)	BAND (MHz)	TUNE CONTROL COUNTER READINGS	LOAD CONTROL*	PLATE CURRENT (MA)
2.3	2.0 - 2.6	131	4.0	380
2.8	2.6 - 3.0	138	4.0	380
4.0	3.0 - 5.0	109	0	320
6.0	5.0 - 8.0	101	6.8	340
8.0	8.0 - 12.0	104	6.8	400
11.0	8.0 - 12.0	078	6.2	340
14.0	12.0 - 16.0	078	2.2	360
16.0	16.0 - 24.0	094	1.2	340
20.0	16.0 - 24.0	078	1.8	450
24.0	24.0 - 30.0	082	1.0	420
28.0	24.0 - 30.0	072	1.0	520

\*Maximum counterclockwise position is LOAD control setting of 0; maximum clockwise is setting of 12.

Once the transmitter has been tuned on carrier as per Table 3-4, it is ready for operation in an intelligence mode. Exciter control positions for the various intelligence modes of operation are outlined in the MMX(M)-2 Technical Manual.

## SECTION 4

### THEORY OF OPERATION

#### 4-1. OVERALL BLOCK DIAGRAM ANALYSIS.

Figure 4-1 is an overall block diagram of the HFTM-1KJ2 transmitter. Power input of 115/230 vac, 50/60 hz is applied via J2001 to the AP152 high voltage power supply and to the MMX(M)-2 exciter.

Intelligence inputs to the transmitter are applied via the interface panel to the exciter; these inputs include line audio (for both upper and lower sidebands), frequency shift keying, facsimile, and exciter PTT control. A CW keyline input also appears on the interface panel and is routed to the exciter via a switch on the AX5040 test key panel. The test key switch provides CW keyline closure for tuning and test purposes.

Transmitter control inputs to the HFTM-1KJ2 are also applied via the interface panel; these inputs include control lines for high voltage on circuitry, transmitter PTT, overload reset, and external interlocks. External control of the transmitter is optional; however, if the external control inputs are not utilized, jumper connections must be made at the interface panel to complete transmitter circuitry.

The MMX(M)-2 provides an rf output (J124) of at least 100 milliwatts (250 millivolts) within the frequency range of 1.5 to 30 mhz in any of the following modes: AM, USB, LSB, ISB including AME, CW, FSK or FAX. The exciter output is applied via J1004 and the rf gain control to the chain of amplifiers within the TLAM-1K linear power amplifier. The AP151 low voltage and bias supply and AP152 high voltage supply provide the dc operating potentials for the linear amplifier chain.

The rf output of the TLAM-1K is one kilowatt PEP and average throughout the frequency range of the transmitter. This output is applied via J1006 to J10 on the interface panel. The antenna connection is made at J10.

The TLAM-1K provides an ALDC (automatic load and drive control) feedback voltage to the MMX(M)-2 exciter, which prevents the rf output of the transmitter from exceeding a preset level. The ALDC circuit in the exciter automatically compensates for high modulation peaks and load changes, providing a relatively constant output level, in addition to limiting distortion and improving linearity.

The transmitter provides readback information (high voltage on status, overload status, etc.); the readback outputs appear on the interface panel, where external monitoring connections should be made.

#### 4-2. FUNCTIONAL ASSEMBLY SECTIONS.

Refer to the associated technical manuals for detailed theory of operation for the MMX(M)-2 Multi-Mode Exciter and the HFLM-1K High Frequency Linear Power Amplifier.

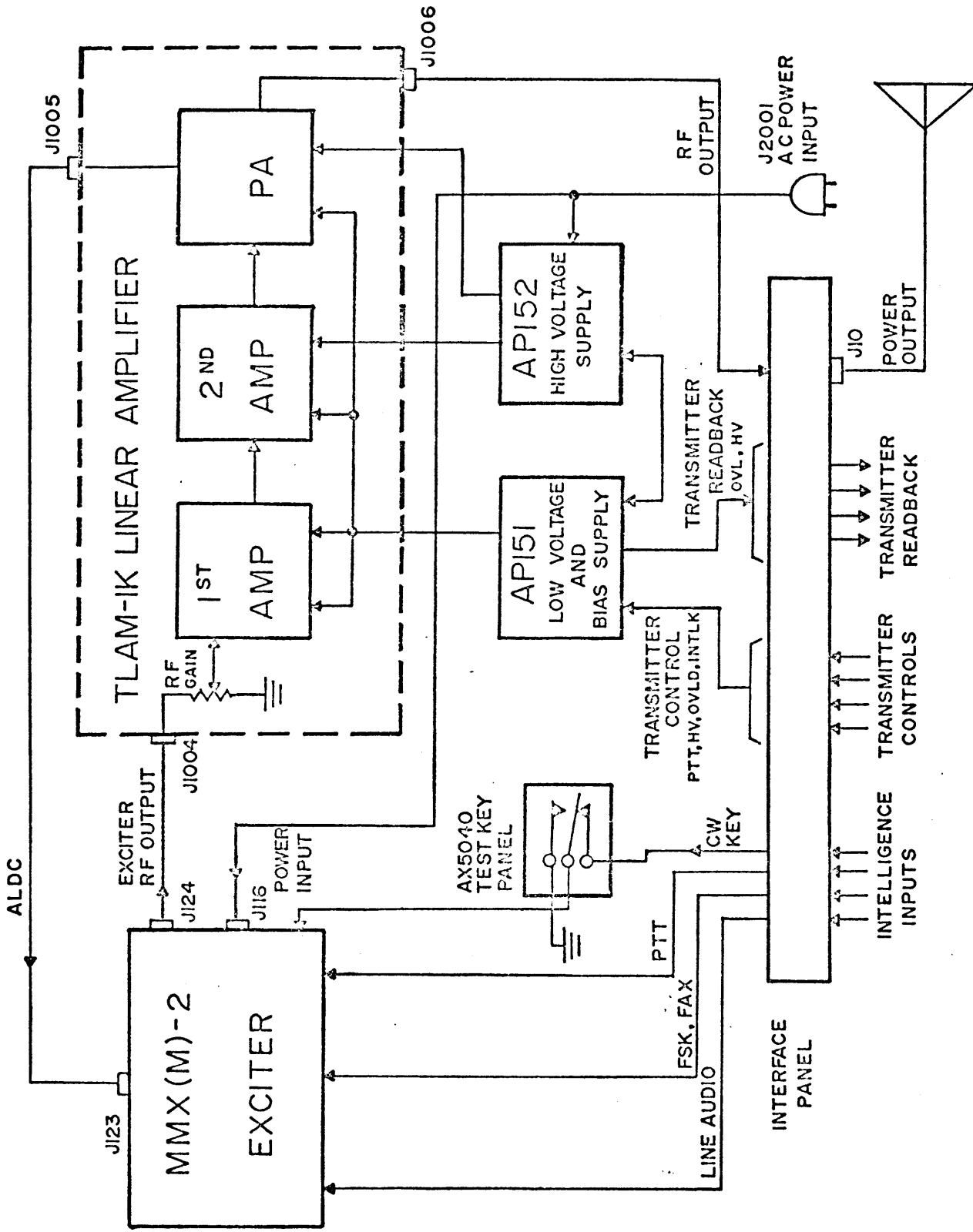

Figure 4-1. HFTM-1KJ2 Overall Block Diagram

## SECTION 5

### MAINTENANCE AND TROUBLESHOOTING

#### 5-1. INTRODUCTION.

The HF1M-1KJ2 transmitter has been designed for long term, trouble-free operation. When it becomes necessary to perform alignment and/or adjustments to the equipment, it is recommended that technicians perform the necessary operations outlined in the associated HF1M-1K and MMX(M)-2 technical manuals. The following maintenance aids are provided for troubleshooting and replacement of parts:

- a. Overall block diagram (Section 4, figure 4-1).
- b. Interconnect wiring diagram (Section 2, figure 2-4).

#### 5-2. TEST EQUIPMENT REQUIRED.

Table 5-1 lists the test equipment required for maintaining and troubleshooting the transmitter. Refer to the MMX(M)-2 and HF1M-1K technical manuals for additional equipment required to maintain and troubleshoot these two components.

TABLE 5-1. TEST EQUIPMENT REQUIRED

EQUIPMENT	TYPE
Signal Generator	Hewlett-Packard Model 606A, or equivalent
VTVM	Hewlett-Packard Model 410B, or equivalent
Multimeter	Simpson Model 260, or equivalent
Oscilloscope	Tektronix, Model 541A, or equivalent

#### 5-3. OPERATOR'S MAINTENANCE PROCEDURE.

- a. Refer to transmitter operating procedures (Tables 3-2, 3-3, and 3-4).
- b. Refer to troubleshooting (paragraph 5-5).
- c. Refer to maintenance procedures described in the HF1M-1K and MMX(M)-2 technical manuals.

#### 5-4. PREVENTIVE MAINTENANCE.

In order to prevent equipment failure due to dust, dirt or other destructive elements, it is suggested that a schedule of preventive maintenance be set up and adhered to. At periodic intervals, the equipment should be pulled out on its slides for internal cleaning and inspection. The wiring and all components should be inspected for dirt, dust, corrosion, grease or other harmful conditions. Remove dust with a soft brush or vacuum cleaner. Remove dirt or grease with any suitable cleaning solvent. Use of carbon tetrachloride should be avoided due to its highly toxic effects. Trichlorethylene or Methyl Chloroform may be used, providing the necessary precautions are observed. For detailed preventive maintenance procedures, refer to the applicable HFIM-1K and MMX(M)-2 technical manuals.

#### WARNING

WHEN USING TOXIC SOLVENTS, MAKE CERTAIN THAT ADEQUATE VENTILATION EXISTS. AVOID PROLONGED OR REPEATED BREATHING OF THE VAPOR. AVOID PROLONGED OR REPEATED CONTACT WITH SKIN. FLAMMABLE SOLVENTS SHALL NOT BE USED ON ENERGIZED EQUIPMENT OR NEAR ANY EQUIPMENT FROM WHICH A SPARK MAY BE RECEIVED. SMOKING, "HOT-WORK", ETC. IS PROHIBITED IN THE IMMEDIATE AREA.

#### CAUTION

When using trichlorethylene, avoid contact with painted surfaces, due to its paint-removing effects.

#### 5-5. TROUBLESHOOTING.

Troubleshooting the HFIM-1KJ2 consists of isolating faults to either the MMX(M)-2 exciter or the HFIM-1K power amplifier. Refer to the associated technical manuals for detailed troubleshooting procedures of the MMX(M)-2 and HFIM-1K. Refer to operator's section for normal indications.

a. Disconnect the MMX(M)-2 rf output from the HFIM-1K and connect the MMX(M)-2 to a 50 ohm, 1 watt, non-inductive dummy load. Use an oscilloscope to monitor the exciter output, referring to the MMX(M)-2 technical manual for normal indications.

b. Use an ohmmeter to check for continuity of interconnect cabling between the MMX(M)-2 and HFIM-1K. (Refer to figure 2-4.)

c. Disconnect the MMX(M)-2 and connect a signal generator to the HFIM-1K input. Operate the HFIM-1K into a dummy load (if available) and monitor the HFIM-1K meters for proper operation. (Refer to Table 3-4 and the HFIM-1K technical manual for normal indications.)

SECTION 6

PARTS LIST

6-1. INTRODUCTION.

The HFTM-1KJ2 transmitter consists of the MMX(M)-2 exciter, AX5040 test key panel, and HF1M-1K linear power amplifier, all housed in the RAK139-1A equipment cabinet. The parts lists for the MMX(M)-2 exciter and HF1M-1K linear power amplifier are contained in their respective modular technical manuals; the parts lists for the AX5040 test key panel and RAK139-1A equipment cabinet are contained in this section.

6-2. GENERAL.

Reference designations have been assigned to identify all Subassembly/PC Card parts of the equipment. They are used for marking the equipment and are included on drawings, diagrams, and in the parts list. The letters of a reference designation indicate the kind of part (generic group), such as resistor, capacitor, unit, subassembly, PC card, transistor, integrated circuit, electron tube, etc. The number differentiates between parts of the same generic group. Sockets associated with a particular plug-in device, such as electron tubes or lamps, are identified with a reference designation which includes the reference designation of the plug-in device. Column 1 lists the reference designations of the various parts in alphabetical order and numerical order. Column 2 gives the names and describes the various parts. Major part assemblies are listed in their entirety; subparts of a major assembly are listed in alphabetical and numerical order with reference to the major assembly. Column 3 lists each Technical Materiel Corporation part number.

TABLE 6-1. PARTS LIST FOR AX5040  
TEST KEY PANEL

REFERENCE SYMBOL	DESCRIPTION	TMC PART NO.
S1001 TB1001	Switch Terminal Strip, Barrier	SW186-3 TM102-2

TABLE 6-2. PARTS LIST FOR RAK139-1A  
EQUIPMENT CABINET

REFERENCE SYMBOL	DESCRIPTION	TMC PART NO.
J2001 S2001 S2002	Connector, Receptacle Switch, Interlock Same as S2001	JJ297-1 SW230