

★
UNCLASSIFIED

TECHNICAL MANUAL

for

FREQUENCY STANDARD

MODEL CSS-2

(0-1275/UR)



THE TECHNICAL MATERIEL CORPORATION
MAMARONECK, N. Y.

OTTAWA, CANADA

★

★
UNCLASSIFIED

TECHNICAL MANUAL
for
FREQUENCY STANDARD
MODEL CSS-2
(0-1275/UR)



THE TECHNICAL MATERIEL CORPORATION
MAMARONECK, N. Y. OTTAWA, CANADA

COPYRIGHT 1970
THE TECHNICAL MATERIEL CORPORATION

★
IN-6005

Issue Date: 30 October 1970

NOTICE

THE CONTENTS AND INFORMATION CONTAINED IN THIS INSTRUCTION MANUAL IS PROPRIETARY TO THE TECHNICAL MATERIEL CORPORATION TO BE USED AS A GUIDE TO THE OPERATION AND MAINTENANCE OF THE EQUIPMENT FOR WHICH THE MANUAL IS ISSUED AND MAY NOT BE DUPLICATED EITHER IN WHOLE OR IN PART BY ANY MEANS WHATSOEVER WITHOUT THE WRITTEN CONSENT OF THE TECHNICAL MATERIEL CORPORATION.

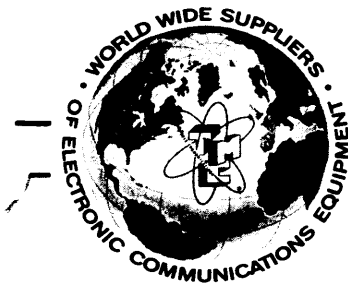

THE TECHNICAL MATERIEL CORPORATION

C O M M U N I C A T I O N S E N G I N E E R S

700 FENIMORE ROAD

MAMARONECK, N. Y.

W a r r a n t y

The Technical Materiel Corporation, hereinafter referred to as TMC, warrants the equipment (except electron tubes,* fuses, lamps, batteries and articles made of glass or other fragile or other expendable materials) purchased hereunder to be free from defect in materials and workmanship under normal use and service, when used for the purposes for which the same is designed, for a period of one year from the date of delivery F.O.B. factory. TMC further warrants that the equipment will perform in a manner equal to or better than published technical specifications as amended by any additions or corrections thereto accompanying the formal equipment offer.

TMC will replace or repair any such defective items, F.O.B. factory, which may fail within the stated warranty period, PROVIDED:

1. That any claim of defect under this warranty is made within sixty (60) days after discovery thereof and that inspection by TMC, if required, indicates the validity of such claim to TMC's satisfaction.
2. That the defect is not the result of damage incurred in shipment from or to the factory.
3. That the equipment has not been altered in any way either as to design or use whether by replacement parts not supplied or approved by TMC, or otherwise.
4. That any equipment or accessories furnished but not manufactured by TMC, or not of TMC design shall be subject only to such adjustments as TMC may obtain from the supplier thereof.

Electron tubes*furnished by TMC, but manufactured by others, bear only the warranty given by such other manufacturers. Electron tube warranty claims should be made directly to the manufacturer of such tubes.

TMC's obligation under this warranty is limited to the repair or replacement of defective parts with the exceptions noted above.

At TMC's option any defective part or equipment which fails within the warranty period shall be returned to TMC's factory for inspection, properly packed with shipping charges prepaid. No parts or equipment shall be returned to TMC, unless a return authorization is issued by TMC.

No warranties, express or implied, other than those specifically set forth herein shall be applicable to any equipment manufactured or furnished by TMC and the foregoing warranty shall constitute the Buyers sole right and remedy. In no event does TMC assume any liability for consequential damages, or for loss, damage or expense directly or indirectly arising from the use of TMC Products, or any inability to use them either separately or in combination with other equipment or materials or from any other cause.

*Electron tubes also include semi-conductor devices.

PROCEDURE FOR RETURN OF MATERIAL OR EQUIPMENT

Should it be necessary to return equipment or material for repair or replacement, whether within warranty or otherwise, a return authorization must be obtained from TMC prior to shipment. The request for return authorization should include the following information:

1. Model Number of Equipment.
2. Serial Number of Equipment.
3. TMC Part Number.
4. Nature of defect or cause of failure.
5. The contract or purchase order under which equipment was delivered.

PROCEDURE FOR ORDERING REPLACEMENT PARTS

When ordering replacement parts, the following information must be included in the order as applicable:

1. Quantity Required.
2. TMC Part Number.
3. Equipment in which used by TMC or Military Model Number.
4. Brief Description of the Item.
5. The *Crystal Frequency* if the order includes crystals.

PROCEDURE IN THE EVENT OF DAMAGE INCURRED IN SHIPMENT

TMC's Warranty specifically excludes damage incurred in shipment to or from the factory. In the event equipment is received in damaged condition, the carrier should be notified immediately. Claims for such damage should be filed with the carrier involved and not with TMC.

All correspondence pertaining to Warranty Claims, return, repair, or replacement and all material or equipment returned for repair or replacement, within Warranty or otherwise, should be addressed as follows:

THE TECHNICAL MATERIEL CORPORATION
Engineering Services Department
700 Fenimore Road
Mamaroneck, New York

TABLE OF CONTENTS

Paragraph		Page	Paragraph		Page
SECTION 1 — GENERAL INFORMATION			SECTION 5 — MAINTENANCE		
1-1	Description	1-1	5-1	General	5-1
1-2	Technical Specifications	1-1	5-2	Preventive Maintenance	5-3
1-3	Transistor and Diode Complement	1-1		a. General	5-3
				b. Scheduling	5-3
SECTION 2 — INSTALLATION			5-3	Troubleshooting	5-3
2-1	Initial Inspection	2-1	5-4	Repair of Printed Circuits	5-3
2-2	Power Requirements	2-1	5-5	Alignment	5-4
2-3	Installation	2-1		a. Preliminary Instructions	5-4
	Mechanical	2-1		b. 1 MC, 10 MC and 100 KC Alignment	5-4
	Electrical	2-1		(1) 1 MC Alignment	5-4
2-4	Pre-Operational Check	2-3/2-4		(2) 10 MC Alignment	5-4
				(3) 100 KC Alignment	5-5
SECTION 3 — OPERATOR'S SECTION				c. Coarse and Fine Frequency Linearity Adjustments	5-5
3-1	Controls and Indicators	3-1		(1) Coarse Varicap Volt- age Adjustment	5-5
3-2	Operating Procedures	3-2/3-3		(2) Fine Frequency Lin- earity Adjustment	5-6
SECTION 4 — PRINCIPLES OF OPERATION				d. Absolute 1 MC Frequency Adjustment	5-6
4-1	Overall Description	4-1	SECTION 6 — PARTS LIST		
4-2	1-mc Source	4-1	SECTION 7 — SCHEMATIC DIAGRAMS		
4-3	Calibration and Metering Circuits	4-1			
4-4	Power Supply Circuit	4-1			

LIST OF ILLUSTRATIONS

Figure	Page	Figure	Page
SECTION 1 — GENERAL INFORMATION		SECTION 4 — PRINCIPLES OF OPERATION	
1-1	1-0	4-1	4-2
SECTION 2 — INSTALLATION		SECTION 5 — MAINTENANCE	
2-1	2-1	5-1	5-2
2-2	2-2	5-2	5-2
2-3	2-2		
SECTION 3 — OPERATOR'S SECTION		SECTION 7 — SCHEMATIC DIAGRAMS	
3-1	3-2/3-3	7-1	7-3/7-4

LIST OF TABLES

Table	Page	Table	Page
SECTION 1 — GENERAL INFORMATION		SECTION 5 — MAINTENANCE	
1-1	Transistor and Diode Complement	5-1	Tools and Test Equipment Required
	1-2		5-1
SECTION 3 — OPERATOR'S SECTION			
3-1	Controls and Indicators		
	3-1		

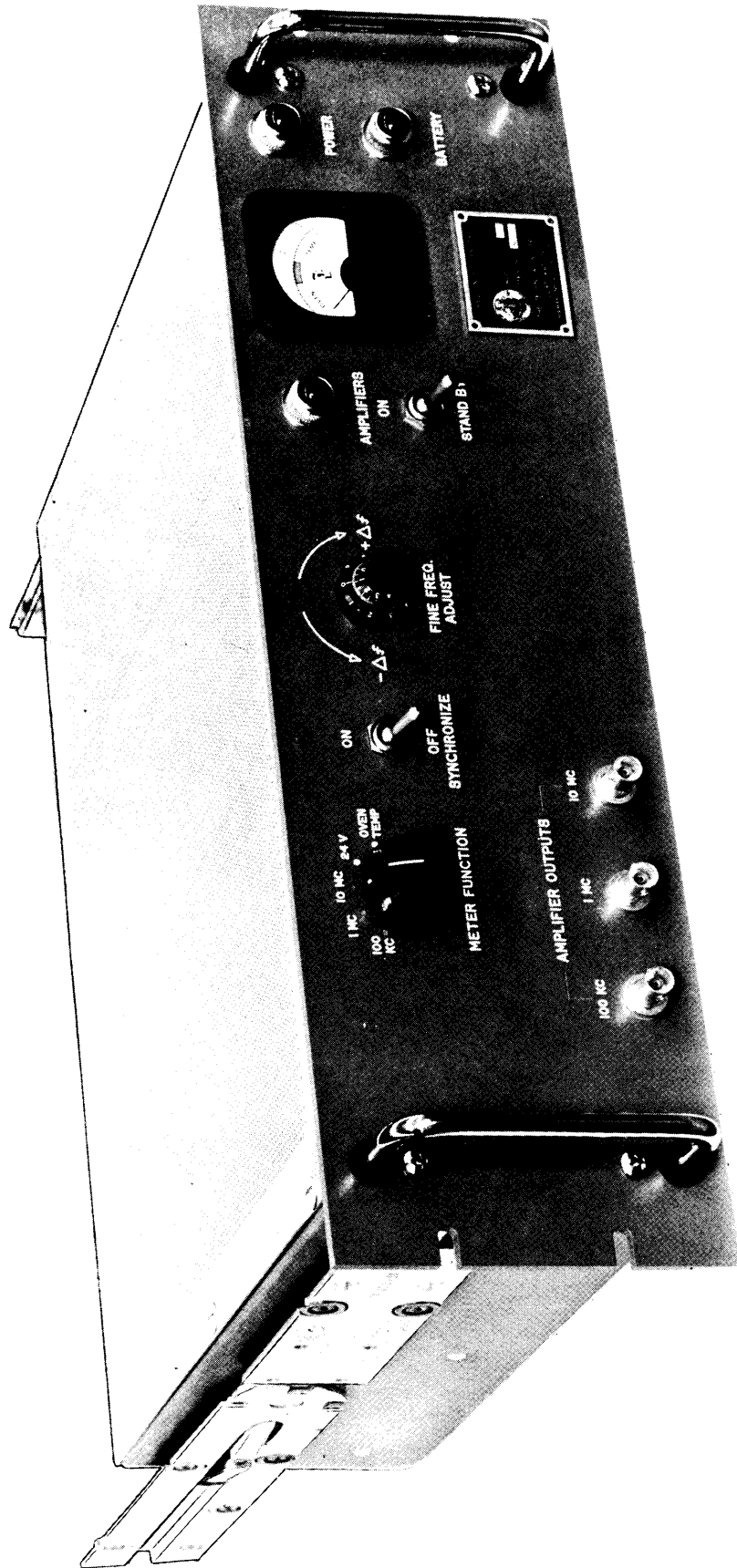

Figure 1-1. Frequency Standard, Model CSS-2

SECTION 1

GENERAL INFORMATION

1-1. DESCRIPTION.

Frequency Standard, Model CSS-2 (figure 1-1), is a highly stable signal source capable of generating 1-mc, 10-mc, and 100-kc frequency references, with a long term stability of 1 part in 10^9 per day, at a level of 1 volt rms.

The CSS is a compact, transistorized unit, containing its own power supply. It consists of a sealed 1-mc internal frequency standard enclosed in a double proportional temperature controlled oven, a 24-volt regulated power supply, and a printed circuit board with eight integrally mounted transistors. Power for the CSS is normally controlled by front-panel AMPLIFIERS ON/STANDBY switch. In event of an a-c power failure, the CSS contains facilities for automatically switching over the battery power operation.

A 1-mc reference frequency generated by the internal standard is supplied to the CSS transistor circuits which, in turn, provide three frequency outputs: 1-mc, 10-mc, and 100-kc. A double proportional oven maintains the sealed 1-mc frequency standard at its optimum operating temperature. The 100-kc, 1-mc, and 10-mc (low impedance) output jacks are located on both front and rear panels. A 1-mc high impedance output is available at the rear panel only.

All operating controls and indicating devices are located on the front-panel. Two non-indicating type fuses F901 and F903 for a-c and d-c power are located on the rear panel. An additional non-indicating type fuse F902, for protecting the internal sealed 1-mc frequency standard, is located on the underside of the chassis.

The CSS measures 5-1/4 inches high by 13-3/4 inches deep (excluding front panel controls) and is mounted on a 19-inch wide front panel. The unit weighs approximately 8 pounds.

1-2. TECHNICAL SPECIFICATIONS.

Technical specifications of the CSS are as follows:

Frequency Stability:	1 part in 10^9 for 24 hours after a warm-up period of 24 hours.
Frequency Adjustment:	Multi-turn FINE FREQ ADJUST (front panel) control R952 contains 1000 divisions, which provides

1-2. TECHNICAL SPECIFICATIONS (CONT).

Frequency Adjustment: (cont)	total deviation of ± 100 parts in 10^9 with resettable accuracy of 1 part in 10^9 .
Electronic Correction:	The frequency of the standard can be varied ± 100 parts in 10^9 by application of appropriate DC control voltage.
Crystal Oven Temperature:	Proportional heat supply, varying inversely with changes in ambient temperature.
Outputs(Front Panel):	<ol style="list-style-type: none"> 1. 1 mc at 1 volt across 50 ohm load (BNC). 2. 100 kc at 1 volt across 50 ohm load (BNC). 3. 10 mc at 1 volt across 50 ohm load (BNC). (1, 2 and 3 are outputs from transistor amplifiers.)
Outputs (Rear Panel):	<ol style="list-style-type: none"> 1. 1 mc at 1 volt across 50 ohm load (BNC). 2. 100 kc at 1 volt across 50 ohm load (BNC). 3. 10 mc at 1 volt across 50 ohm load (BNC). (1, 2 and 3 are in parallel with front panel outputs.) 4. 1 mc output direct from standard through isolation resistor.
Front Panel Meter:	Meter M901 monitors 24 vdc (B+) supply voltage; indicates correct oven temperature and monitors all amplified output signals.
A-c Power Requirements:	115/230 volts, 50/60 cps, single phase power, 10 watts maximum.
D-c Power Requirements:	Unit capable of operating with externally connected 24-volt batteries. Power consumption on battery operation is 5 watts (330 milliamperes).

1-3. TRANSISTOR AND DIODE COMPLEMENT.

Table 1-1 lists the transistors and diodes for the CSS.

TABLE 1-1. TRANSISTOR AND DIODE COMPLEMENT

REFERENCE SYMBOL	TYPE	FUNCTION
Q901	2N1224	Buffer amplifier
Q902	2N1224	Times two Multiplier
Q903	2N1224	Times five Multiplier
Q904	2N1224	Buffer amplifier
Q905	2N1224	Buffer amplifier
Q906	2N1224	10-to-1 Divider-mixer
Q907	2N1224	Times three Multiplier
Q908	2N1224	Times three Multiplier
Q909	2N1487	Voltage regulator
CR901	1N3157A	Zener diode regulator; part of biasing circuit for internal 1-mc frequency standard.
CR902	1N39B	Metering circuit diode; rectifies amplified 1-mc output frequency signal.
CR903	1N39B	Metering circuit diode; rectifies amplified 100-kc output frequency signal.
CR904	1N39B	Metering circuit diode; rectifies amplified 10-mc output frequency signal.
CR905 through CR908	1N1582R	B+ bridge rectifier diodes.
CR909	1N1582R	In battery operation, disconnects battery supply line from POWER indicator DS901 and relay K901.
CR910	VR101-24-S51	Zener diode; sets bias level for voltage regulator Q909.
CR911	1N2484	

SECTION 2 INSTALLATION

2-1. INITIAL INSPECTION.

The CSS has been calibrated and tested at the factory before shipment. Upon arrival at the operating site, inspect the packing case and its contents immediately for possible damage. Unpack the equipment carefully; inspect all packing material for parts that may have been shipped as loose items. With respect to damage to the equipment for which the carrier is liable, the Technical Materiel Corporation will assist in describing methods of repair and the furnishing of replacement parts.

2-2. POWER REQUIREMENT.

The CSS is factory wired for 115-volt a-c, 50/60-cycle, single-phase operation, unless otherwise specified by the customer at the time of purchase. For 230-volt a-c operation, make the necessary wiring changes as shown in figure 2-1. With 230-volt a-c operation, change the ampere rating of AC fuse F901 from 1- to 1/2-ampere.

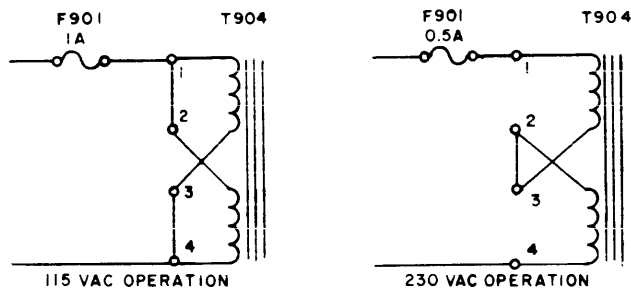

Figure 2-1. Power Supply Changeover Connections

2-3. INSTALLATION.

a. MECHANICAL. - The CSS is designed for rack installation. Adequate ventilation, sufficient clearance in back of the unit for access to rear-panel connections, and sufficient space for withdrawal of the unit from the rack for servicing are prime considerations when determining ultimate location. The CSS is equipped with a standard 19-inch wide front panel, and is 5-1/4 inches high and 13-3/4 inches deep.

When the CSS is supplied as part of a rack mounted system, tilt slide mechanisms are provided. To install the CSS, proceed as follows:

(1) Set the CSS chassis slide mechanism in tracks.

(2) Slide chassis in tracks until rearward release finger engages holes in track.

(3) Make the necessary cable and electrical connections as described in paragraph b.

(4) Press forward release fingers and slide chassis into cabinet; secure front-panel of CSS to rack with screws.

b. ELECTRICAL. - Refer to figures 2-2 and 2-3 and proceed as follows:

(1) Set AMPLIFIERS ON/STANDBY switch S903 at STANDBY.

(2) Connect a-c power cable between MAIN AC jack J910 and a-c power source receptacle. POWER indicator DS901 should light.

CAUTION

To avoid damage to components within the CSS, observe for proper polarity when connecting battery to BATTERY jack J911.

(3) If a 24-volt d-c battery power source is available, connect battery observing proper polarity to BATTERY jack J911. (Connect positive side of battery to pin 6 of J911.)

(4) With a 24-volt d-c battery connected as described in b-3 above, set BAT. switch S904 at IN. If battery is not available, or ready for use at this time, set BAT. switch S904 at OUT.

NOTE

Each frequency output jack located on the front panel is paired (parallel connected), with an output jack located on the rear panel. If during installation, both front and rear parallel connected jacks are utilized, it should be noted that the total impedance for any pair of jacks should not be less than 50 ohms. For example, if step h is performed, use two 100-ohm loads or a combination of one 50-ohm load on one jack and greater than 1000 ohms on the other.

(5) Connect coaxial cable between 1 MC AMPLIFIER OUTPUTS jack J907 and load, and, if necessary connect coaxial cable(s) between 100 KC and/or 10 MC AMPLIFIER OUTPUTS jack (s) J906 and J908 and their respective load(s). When the CSS-2 is supplied as a unit of the LRRRA-1 system, make the connection for the 1-volt 100-kc output to the BNC tee connector connected to J903; and make

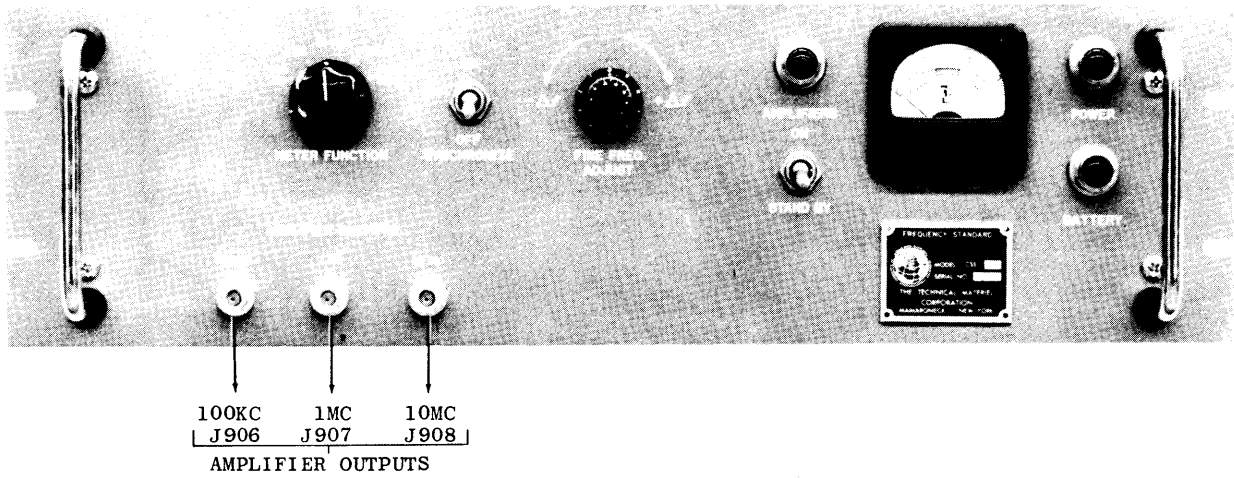

Figure 2-2. Front-Panel Connections

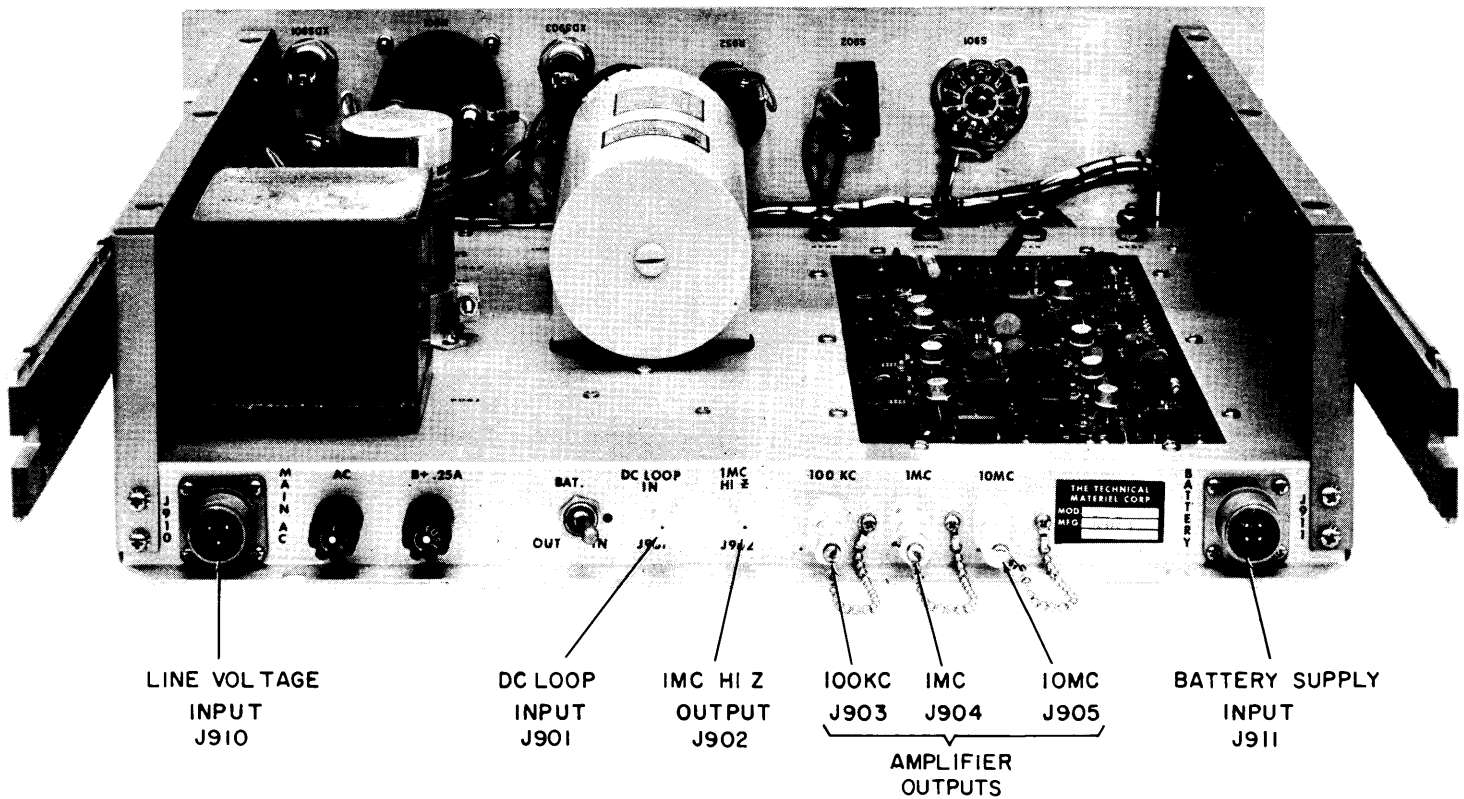

Figure 2-3. Rear-Panel Connections

the connection for the 1-millivolt 100-kc output to the BNC connector on attenuator AT904.

NOTE

All output frequencies referred to in step (5) may be utilized at the same time.

(6) Disconnect 50-ohm dummy load(s) for applicable frequencies utilized in step (5).

NOTE

The 50-ohm dummy loads associated with the 100-kc, 1-mc, and 10-mc frequencies are located on the rear panel and connected to their respective 100 KC, 1 MC and 10 MC jacks, J903, J904 and J905.

(7) If two 100-kc, 1-mc, and/or 10-mc frequency outputs are required, connect coaxial cable(s) between 100 KC, 1 MC and/or 10 MC jacks J903, J904 and/or J905 located on the rear panel and respective load(s). (The remaining appropriate cable connections were performed in step (5).)

(8) If 1-mc high impedance output source is required, connect coaxial cable between rear panel 1 MC HI Z jack J902 and load.

2-4. PRE-OPERATIONAL CHECK.

To check that the CSS is operating properly, perform the following:

a. Ensure that AMPLIFIERS ON/STANDBY switch S903 is set at STANDBY.

NOTE

The readings obtained on Meter M901 in step b should be multiplied by 10.

b. Set METER FUNCTION selector switch S901 at 24 V; meter M901 should indicate approximately 24 volts.

c. If a 24-volt battery power source is connected to BATTERY jack J911, make certain that BAT. switch S904 is set at IN.

d. Disconnect a-c power cable from main AC jack J910; Power indicator DS901 should go out, and BATTERY indicator DS902 should light. Meter M901 should indicate approximately 24 volts.

e. Reconnect a-c power cable to MAIN AC jack J910. BATTERY lamp DS902 should go off, and POWER indicator DS901 should light.

f. Allow unit to warm-up for period of 24 hours.

g. After unit has warmed up for 24 hours, set AMPLIFIERS ON/STANDBY switch S903 at ON; AMPLIFIERS ON indicator DS903 should light. Set METER FUNCTION selector switch S901 at OVEN TEMP. Meter M901 should indicate within the green area.

NOTE

When performing steps h, i, and j a frequency counter may be used only as a quick check. Alignment of the CSS requires the use of 1-mc r-f source with a higher stability than that of the CSS. Such stability can be obtained by use of TMC Model VLFC-1, VLF Frequency Standard Comparison System.

h. Connect frequency counter (Hewlett-Packard Model 5245L or equivalent) to 1 MC AMPLIFIER OUTPUTS jack J907. Frequency counter and VTVM should indicate 1 mc ± 1 count, and 1 volt rms minimum, respectively. If not, 1-mc tuned amplifier circuit is out of adjustment (refer to paragraph 5-5).

i. Disconnect frequency counter and VTVM from 1 MC AMPLIFIER OUTPUTS jack and connect to 100 KC AMPLIFIER OUTPUTS jack J906. Frequency counter and VTVM should indicate 100 kc ± 1 count and 1 volt rms minimum, respectively. If not, 100-kc tuned amplifier circuit is out of adjustment (refer to paragraph 5-5).

j. Disconnect frequency counter and VTVM from 100 KC AMPLIFIER OUTPUTS jack and connect to 10 MC AMPLIFIER OUTPUTS jack J908. Frequency counter and VTVM should indicate 10 mc ± 10 counts and 1 volt rms minimum, respectively. If not, 10-mc tuned amplifier circuit is out of adjustment (refer to paragraph 5-5).

k. Set AMPLIFIERS ON/STANDBY switch S903 at STANDBY. AMPLIFIERS ON indicator DS903 should go off.

SECTION 3

OPERATOR'S SECTION

3-1. CONTROLS AND INDICATORS.

Before attempting to operate Frequency Standard CSS, the operator should first familiarize himself

with all controls and indicators. All operating controls and indicators are located on the front panel (refer to figure 3-1). The function of each control and indicator, together with its nomenclature and reference designation, is given in table 3-1.

TABLE 3-1. CONTROLS AND INDICATORS

ITEM NO. (Ref Fig 3-1)	CONTROL OR INDICATOR	FUNCTION
1	METER FUNCTION switch S901	Five-position (100 KC, 1 MC, 10 MC, 24 V and OVEN TEMP) selector switch. Switch is manually operated in conjunction with meter M901 to check outputs of 100-kc, 1-mc, and 10-mc circuits. Also used to check 24-volt supply voltage as well as oven temperature.
2	SYNCHRONIZE switch S902	ON position, connects external d-c correction voltage to 1-mc internal frequency standard.
3	FINE FREQ ADJUST control R952	10-turn vernier control used in calibrating 1-mc internal frequency standard. Each full turn produces 2/100 of a cycle change at 1 mc. Total deviation is $\pm 1/10$ of a cycle at 1 mc.
4	AMPLIFIERS ON indicator DS903	Indicates 24-vdc is supplied to CSS circuits.
5	Meter M901	Monitors 100-kc, 1-mc, and 10-mc signal output level; 24-volt supply voltage; and oven temperature as selected by METER FUNCTION selector switch S901.
6	POWER indicator DS901	Indicates a-c power is applied to 24-volt power supply circuit.
7	BATTERY indicator DS902	Indicates internal power supply circuit inoperative and unit is capable of being operated from external battery source only.
8	AMPLIFIERS ON/STANDBY switch S903	ON position, connects 24 vdc power to CSS circuits. STANDBY position removes 24 vdc power from CSS circuits.

3-2. OPERATING PROCEDURES.

NOTE

The CSS should be allowed an adequate warm-up period (24 hours) to attain rated stability before operation.

After the unit has warmed up, set AMPLIFIERS ON/STANDBY switch S903 (8) at ON; AMPLIFIERS lamp (4) should light. Operation of the CSS consists of applying or removing an external d-c correction voltage to the internal frequency standard and using meter M901 to check the performance of various CSS circuits. Refer to table 3-1 for a descriptive list of CSS operating controls and indicators.

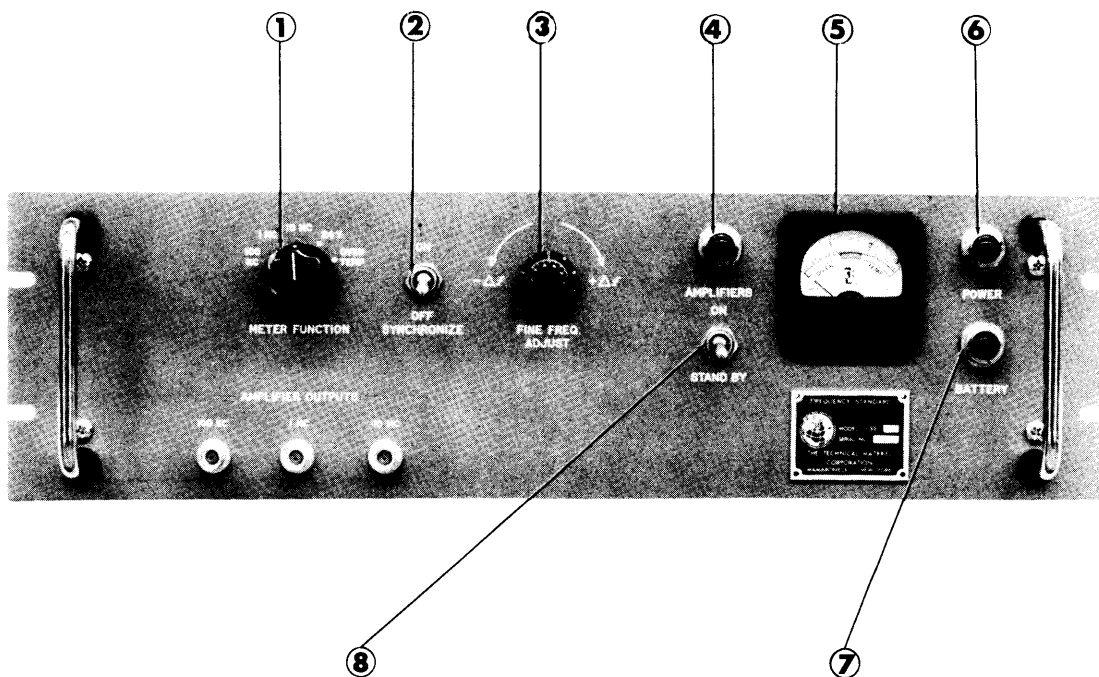

Figure 3-1. Front Panel Controls and Indicators

SECTION 4

PRINCIPLES OF OPERATION

4-1. OVERALL DESCRIPTION.

Refer to figure 4-1. The Frequency Standard CSS is a transistorized unit comprising: a 1-mc source with appropriate multiplier and divider networks which produce highly stable outputs of 100 kc, 1-mc, and 10-mc at 1 volt (rms), minimum, calibration and metering circuits and a regulated 24-volt d-c power supply.

4-2. 1-MC SOURCE.

A stable crystal oscillator is used as the 1-mc standard reference for the CSS. Besides providing 1-mc outputs at jacks J902, J904, and J907, the 1-mc reference source is directly coupled to a 100-kc regenerative-divider and 10-mc frequency multiplier circuits.

The 100-kc regenerative-divider circuit comprising mixer Q906, X3 (times three) multipliers Q907 and Q908, and buffer Q905 produces a 100-kc output at parallel-connected jacks J903 and J906. An additional 100-kc output that is attenuated 60 db by attenuator AT904 is optionally available at the rear

of the chassis. The 10-mc multiplier circuit comprising X2 (times two) multiplier Q902, X5 (times five) multiplier Q903, and buffer Q904 supplies a 10-mc output at parallel connected jacks J905 and J908.

4-3. CALIBRATION AND METERING CIRCUITS

Depending upon the position of front-panel METER FUNCTION switch, the CSS metering circuit monitors: the output voltage at the 100-kc, 1-mc, or 10-mc jacks, the oven temperature of the internal 1-mc frequency standard; or the 24 volt d-c output of the regulated power supply circuit.

4-4. POWER SUPPLY CIRCUIT.

The CSS power supply produces a regulated operating potential of 24 V dc. During normal operation, this voltage supplies power to the internal 1-mc frequency standard and ovens, and to the transistors mounted on the printed circuit board. A portion of the supply voltage is also fed to the 1-mc calibration circuit. This potential is used by the calibration circuits to derive a correction voltage to lock the frequency of the standard at 1 mc.

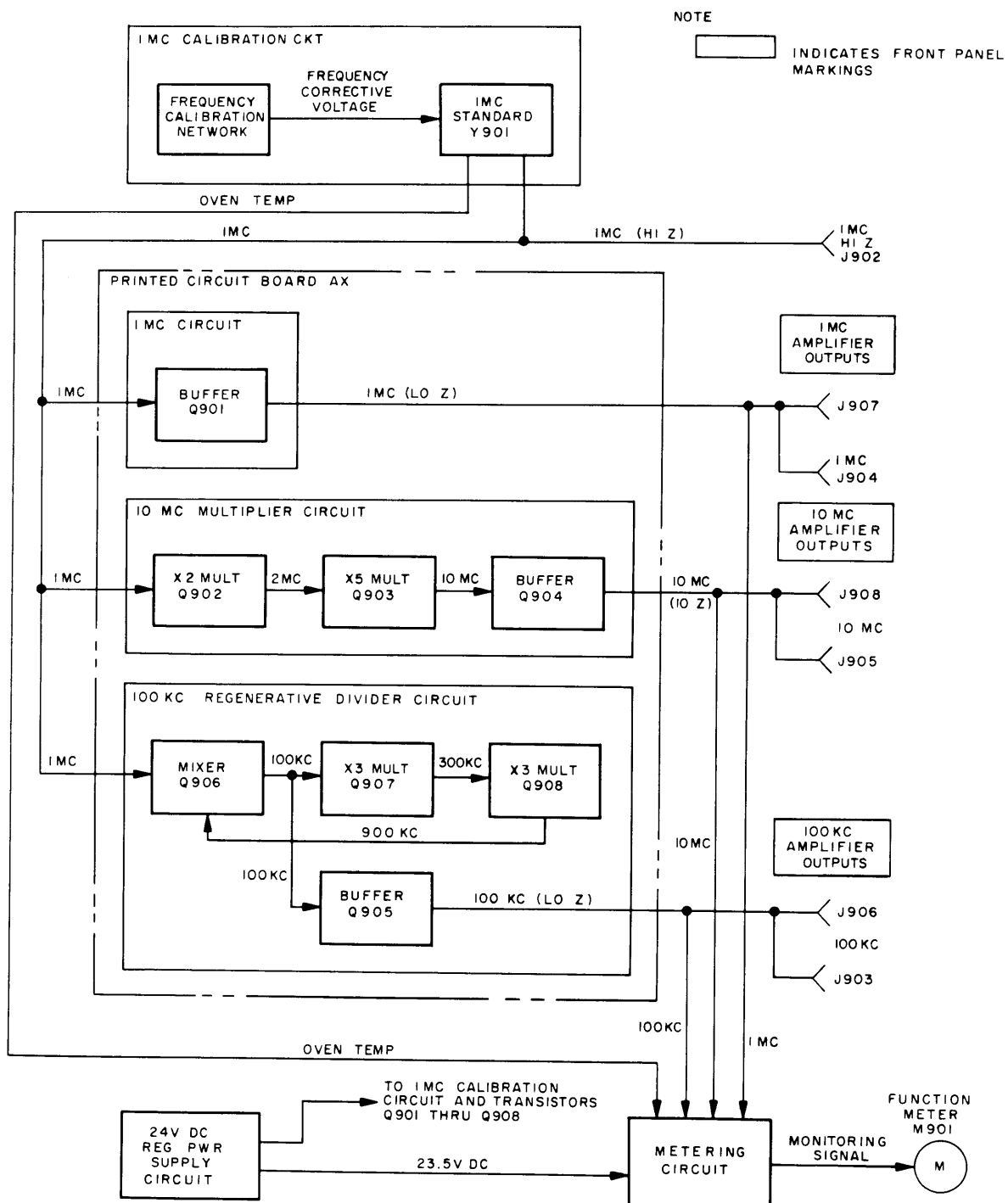

Figure 4-1. CSS Frequency Standard, Functional Block Diagram

SECTION 5 MAINTENANCE

5-1. GENERAL.

To aid in equipment maintenance, the following references are provided: schematic diagram

(Section 7), component identification (figures 5-1 through 5-2), and tools and test equipment required (table 5-1).

TABLE 5-1. TOOLS AND TEST EQUIPMENT REQUIRED

ITEM	DESCRIPTION
Frequency Counter	Hewlett-Packard 5245L or equivalent
Precision Frequency Comparator	TMC PFCB-1 or equivalent
*Frequency Standard	Hewlett-Packard 103AR or equivalent
*VLF Comparator	Hewlett-Packard 117A or equivalent
Signal Generator	Measurements 82 or equivalent
VTVM	Hewlett-Packard 410B or equivalent
24-volt Nickel Cadmium Battery	Sonotone 19-S103 or equivalent
A-c Power Cable	3-wire cable (connectors MS3106A14S1S and three-prong a-c plug connected on either end of cable)
D-c Power Cable	2-wire cable (connectors MD3116A14S2S and battery clips connected on either end of cable)
Resistor (3)	47 ohms, 1/2 Watt (DS/100-47)
Capacitor	0.2 microfarad, 25-volt rating
Connector	MS3106A14S1S
Connector	MS3116A14S2S
Connector	3-prong a-c plug
Connector	Battery clips
Alignment Tools	FMC part numbers TP-100 and TP-129
VOM	Simpson Model 260

*The VLF Comparator, Hewlett-Packard 117A is used in conjunction with Frequency Standard, Hewlett-Packard 103AR, to issue a 1-mc frequency source that is stable to 1 part in 10¹⁰.

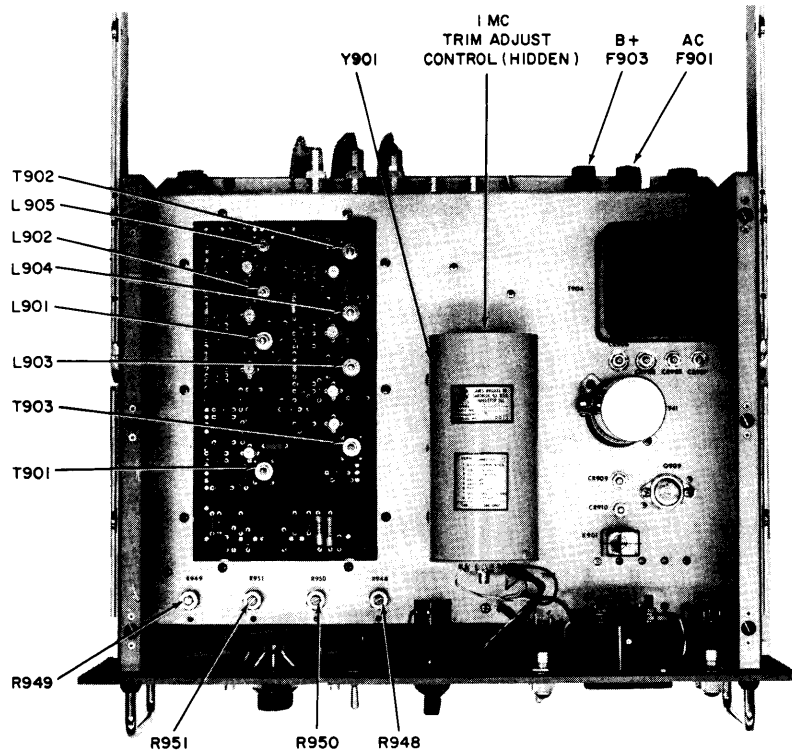

Figure 5-1. CSS Frequency Standard, Top View

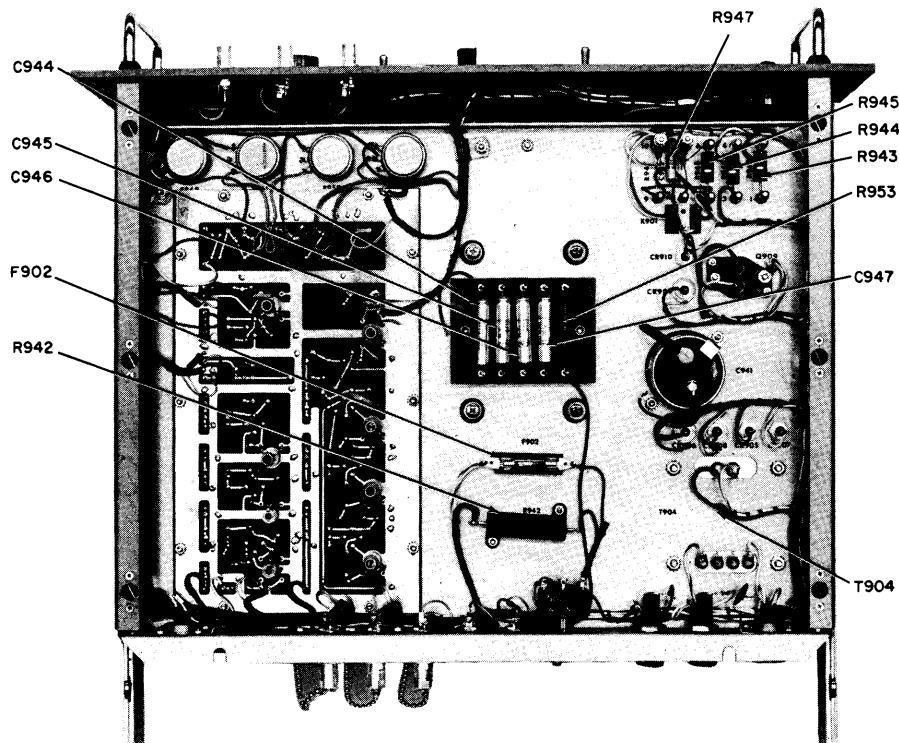

Figure 5-2. CSS Frequency Standard, Bottom View

5-2. PREVENTIVE MAINTENANCE.

a. GENERAL. - The CSS has been designed to provide long term, trouble-free operation under continuous duty conditions. However, in order to prevent failure of the equipment due to corrosion, dust or other destructive elements, it is suggested that a schedule of preventive maintenance be set up and adhered to.

b. SCHEDULING. - At periodic intervals, the equipment should be removed from its mounting for cleaning and inspection. All accessible covers should be removed and the wiring and all components inspected for dirt, corrosion, charring, discoloring or grease. Remove dust with a soft brush or vacuum cleaner. Remove dirt or grease from other parts with any suitable cleaning solvent. Use of carbon tetrachloride should be avoided due to its highly toxic effects. Trichorethylene or methylchloroform may be used, providing the necessary precautions are observed.

WARNING

When using toxic solvents, make certain that adequate ventilation exists. Avoid prolonged or repeated breathing of the vapor. Avoid prolonged or repeated contact with skin. Flammable solvents shall not be used on energized equipment or near any equipment from which a spark may be received. Smoking, "hot work", etc, is prohibited in the immediate area.

CAUTION

When using trichlorethylene, avoid contact with painted surfaces, due to its paint removing effects.

5-3. TROUBLESHOOTING.

When performing overall troubleshooting, use the information contained in paragraph 2-4.

At the first indication of trouble, use METER FUNCTION switch S901 and meter M901 to monitor the five functions of the CSS. This is a fast method of isolating the trouble to a defective circuit. For the 100-kc, 1-mc and 10-mc circuits (positions, 100 KC, 1 MC and 10 MC on METER FUNCTION switch), meter M901 should indicate at least 1-volt rms. To check the output of the power supply circuit (position 24 V on METER FUNCTION switch) meter M901 should indicate 24 volts. To check the oven temperature of the 1-mc standard (position OVEN TEMP on METER FUNCTION switch), meter M901 should indicate within the green area.

The frequency of the 100-kc, 1-mc or 10-mc outputs can be readily checked with a frequency counter connected to the 100 KC, 1 MC or 10 MC AMPLIFIER OUTPUTS jack (located on the front panel). To

check the frequency of the 1-mc standard Y901 directly, connect the counter to 1 MC HI Z jack J902 (located on the rear chassis apron).

NOTE

CSS output frequencies contain a degree of stability which is normally greater than that of a frequency counter. Therefore, a frequency counter may be used only as a quick check of the output frequency.

Use the substitution method to check transistors. Check fuses as necessary. A visual inspection of the unit should pinpoint burned components, broken leads or conduction strips, and loose connections. When a defective component has been isolated, removed and replaced when it is necessary to re-align the CSS (refer to the applicable alignment procedures in paragraph 5-5).

5-4. REPAIR OF PRINTED CIRCUITS.

a. GENERAL. - Although the troubleshooting procedure for printed circuits are similar to those for conventional circuits, the repair of printed circuits requires considerably more skill and patience. The printed circuits are small and compact; therefore, personnel should become familiar with the special servicing techniques required.

The defective parts should be pinpointed by a study of the symptoms and by careful and patient analysis of the circuit before attempting to trace trouble on a printed circuit board. Ascertain whether the conduction strips are coated with a protective lacquer, epoxy resin, or similar substance. If so, carefully scrape it away.

Breaks in the conducting strip (foil) can cause permanent or intermittent trouble. In many instances, these breaks will be so small that they cannot be detected by the naked eye. These almost invisible cracks (breaks) can be located only with the aid of a powerful hand-or stand-held magnifying glass.

b. MULTIMETER CHECKOUT. - The most common cause of an intermittent condition is poorly soldered connections. Other causes are: Broken boards, broken conducting strips, fused conducting strips, arc-over, loose terminals, etc.

CAUTION

Before using an ohmmeter for testing a circuit, transistors or other voltage-sensitive semiconductors, check the current it passes under test on all ranges. DO NOT use a range that passes more than 1 ma.

To check out and locate trouble in the conducting strips of a printed circuit board, set up a multi-

meter for making point-to-point resistance tests, using needle point probes. Insert one point into the conducting strip, close to the end of terminal, and place the other probe on the opposite terminal end of the conducting strip. The multimeter should indicate continuity. If the multimeter indicates an open circuit, drag the probe along the strip (or if the conducting strip is coated, puncture the coating at intervals) until the multimeter indicates continuity. Mark this area then use a magnifying glass to locate the fault in the conductor.

c. HOW TO REPAIR THE BREAK. - If the break in the conducting strip is small, lightly scrape away any coating covering the area of the conducting strip to be repaired. Clean the area with a firm-bristle brush and approved solvent. Then repair the cracked or broken area of the conducting strip by flowing solder over the break. Considerable care must be exercised to keep the solder from flowing onto an adjacent strip.

If a strip is burned out, or fused, cut and remove the damaged strip. Connect a length of insulated wire across the breach or from solder-point to solder-point.

After the repairs are complete, clean the repaired area with a stiff brush and solvent. Allow the board to dry thoroughly, and then coat the repaired area with an epoxy resin or similar compound. This coating not only will protect the repaired area but will help to strengthen it.

CAUTION

After repairs, always scrutinize the board for solder droppings that may cause possible shorts.

Frequently, a low-resistance leakage path will be created by moisture and/or dirt that has carbonized onto the phenolic board. This leakage can be detected by measuring the suspected circuit with a multimeter. To overcome this condition, thoroughly clean the carbonized area with solvent and a stiff brush. If this does not remove it, use a scraping tool (spade end of a solder-aid tool or its equivalent) to remove the carbon, or drill a hole through the leakage path to break the continuity of the leakage. When drilling method is used, be careful not to drill into a part mounted on the other side.

5-5: ALIGNMENT

A. PRELIMINARY INSTRUCTIONS

It is assumed that the CSS has been properly installed as given in section 2 and its internal standard has been allowed to operate continuously for 24 hours.

(1) Ensure that the three 47-ohm dummy loads are connected to the 100 KC, 1 MC and 10 MC jacks (J 903, J 904 and J 905) located on the rear

panel respectively.

(2) Set BAT switch, S 904 at OUT.

(3) Set Synchronize switch, S 902 at OFF.

(4) Set Amplifiers ON/Standby switch, S 903 at ON.

B. 1-MC, 10-MC, AND 100-KC ALIGNMENT.

(1) 1-MC ALIGNMENT. - The 1-mc alignment procedures are performed as follows:

(a) Perform the preliminary instructions given in paragraph 5-5.

(b) Set METER FUNCTION selector switch S 901 at 24V. Function meter M 901 should indicate 24 volts.

(c) Set METER FUNCTION selector switch S 901 at 1 MC.

(d) Connect VTVM between 1 MC AMPLIFIER OUTPUTS jack J 907 and ground.

(e) Adjust transformer T 901 for a maximum indication on VTVM. A minimum of 1 volt rms should be indicated on VTVM.

(f) Adjust control R 948 until function meter M 901 indicates value recorded in step (e), then lock control R 948.

(g) Connect counter to 1 MC AMPLIFIER OUTPUTS jack J 907. Counter should indicate $1 \text{ mc} \pm 1 \text{ cps}$.

(h) Disconnect VTVM and counter from 1 MC AMPLIFIER OUTPUTS jack J 907.

(2) 10-MC ALIGNMENT. - The 10-mc alignment procedures are performed as follows:

(a) Set METER FUNCTION switch S 901 to 10 MC.

(b) Connect VTVM between collector of transistor Q 902 and ground.

(c) Adjust coil L 901 for maximum indication on VTVM.

(d) Disconnect VTVM from collector of transistor Q 902 and connect to collector of transistor Q 903.

(e) Adjust coil L 902 for a maximum indication on VTVM.

(f) Disconnect VTVM from collector of transistor Q 903 and connect to 10 MC AMPLIFIER OUTPUTS jack J 908.

(g) Adjust transformer T 902 for a maximum indication on VTVM.

(h) Readjust coils L 901, L 902 and transformer T 902 in that order for a maximum indication on VTVM. A minimum of 1-volt rms should be indicated on VTVM.

(i) Observe function meter M 901. Meter should indicate value recorded in step (h) \pm 10 per cent.

(j) Connect counter to 10 MC AMPLIFIER OUTPUT jack J 908. Counter should indicate 10 mc \pm 10 cps.

(k) Disconnect VTVM and counter from 10 MC AMPLIFIER OUTPUT jack J 908.

(3) 100-KC ALIGNMENT. - The 100-KC alignment procedures are performed as follows:

(a) Set METER FUNCTION switch S 901 to 100 KC.

(b) Disconnect 1 mc (center) connector P 901 from connector on assembly Y 901.

(c) Connect signal generator through a 0.2 microfarad isolation capacitor, 25-volt rating, to base of transistor Q 906.

(d) Adjust signal generator output for 1 volt rms at 100 KC \pm 5 cps.

(e) Connect VTVM between base of transistor Q 907 and ground.

NOTE

In steps (f), (k) and (p) adjust coils L 903, L 904, L 905 and transformer T 903 fully counterclockwise prior to adjusting for a maximum output indication.

(f) Adjust coil L 903 for a maximum indication on VTVM. Then, adjust transformer T 903 for a maximum indication on function meter M 901.

(g) Disconnect signal generator and VTVM from the base of transistors Q 906 and Q 907, respectively.

(h) Connect signal generator thru isolation capacitor to base of transistor Q 907.

(i) Adjust signal generator output for 1-volt rms at 300 kc \pm 10 cps.

(j) Connect VTVM between base of transistor Q 908 and ground.

(k) Adjust coil L 904 for a maximum indication on VTVM.

(l) Disconnect signal generator and VTVM from transistor Q 907 and Q 908, respectively.

(m) Connect signal generator thru isolation capacitor to base of transistor Q 908.

(n) Adjust signal generator output for 1 volt rms at 900-kilocycles \pm 10 cps.

(o) Connect VTVM between junction of resistor R 941 and coil L 905 and ground.

(p) Adjust coil L 905 for a maximum indication on VTVM.

(q) Disconnect signal generator and VTVM from base of transistor Q908 and junction of resistor R 941 and coil L 905, respectively.

(r) Re-connect connector P 901, disconnected in step (b), to connector on assembly Y 901.

(s) Connect counter to 100 KC AMPLIFIER OUTPUT jack J 906 and ground. Counter should read 100 KC \pm .1 cps.

(t) Readjust transformer T 903 for a maximum indication on function meter M 901. A minimum of 1 volt rms should be indicated on function meter M 901.

(u) Readjust coil L 903 while observing counter, to center of range for which the output frequency remains locked-in at 100 kc. Repeat procedure for coils L 904 and L 905.

(v) Disconnect counter from 100 KC AMPLIFIER OUTPUT jack J 906.

C. COARSE AND FINE FREQUENCY LINEARITY ADJUSTMENTS. - The coarse (varicap voltage) and fine frequency linearity adjustments procedures are performed in steps a and b, and in the order as given. If the frequency of the CSS cannot be adjusted within tolerance, as specified in the fine frequency linearity adjustment procedure, it is recommended that the unit be returned to the Technical Materiel Corporation for padding the 1-mc internal frequency standard Y 901.

(1) COARSE VARICAP VOLTAGE ADJUSTMENT. - To perform the coarse varicap voltage adjustments, proceed as follows:

(a) Perform the preliminary procedures as given in paragraph 5-5.

(b) Connect VTVM between pin 8 (cathode of diode CR 901) on printed circuit board and ground. VTVM should indicate 8.4 \pm 5% volts dc.

(c) Adjust FINE FREQ. ADJUST control R 952 fully counterclockwise.

(d) Disconnect VTVM from pin 8 on printed circuit board and connect to pin 6 (junction of resistors R 905 and R 906) on printed circuit board.

(e) Adjust control R 950 until VTVM indicates 3.2 \pm 5% volts dc on VTVM.

(f) Disconnect VTVM from pin 6 on printed circuit board and ground.

(g) Adjust FINE FREQ. ADJUST control R 952 fully clockwise.

(h) Connect VTVM between junction of FINE FREQ. ADJUST control R 952 and control R 951 and ground.

(i) Adjust control R 951 until VTVM indicates $6.2 \pm 5\%$ volts on VTVM.

(j) Disconnect VTVM from junction of FINE FREQ. ADJUST control R 952 and control R 951 and ground.

(2) FINE FREQUENCY LINEARITY ADJUSTMENT. - To perform the fine frequency linearity adjustments, proceed as follows:

(a) Temporarily connect a 47-ohm, 1/2-watt resistor in parallel with resistor R 907.

(b) Set METER FUNCTION switch S 901 to 10 MC. Meter M 901 should indicate 1 volt minimum.

(c) Connect counter to 10 MC jack J 905.

(d) Adjust counter until it reads down to 0.1 cps at 10 megacycles.

(e) Adjust FINE FREQ. ADJUST control R 952 fully clockwise. Observe and record frequency indicated on counter.

(f) Adjust FINE FREQ. ADJUST control R 952 five turns in a counterclockwise direction. On the fifth turn, line up zero on inner dial so that it coincides with the white division line on top of stationary middle dial. Observe and record frequency indicated on counter.

(g) Adjust FINE FREQ. ADJUST control R 952 fully counterclockwise. Observe and record frequency indicated on counter.

NOTE

At the 10-megacycle reference frequency the permissible plus and minus frequency tolerance is only 1 cps. Therefore, adjustment of FINE FREQ. ADJUST control R 952 is critical. An example for steps (e), (f) and (g) may result in the following:

STEP E

10,000,001.2 cps.

STEP F

10,000,000.4 cps.

STEP G

9,999,999.1 cps.

from the above example, it can be seen that the negative frequency tolerance is excessive by 0.3 cps. If an excessive plus or minus frequency tolerance should occur, proceed to step (h).

(h) Alternately adjust control R 950 (for the lower frequency tolerance) and control R 951 (for the higher frequency tolerance) until the frequency difference in steps (e), (f) and (g) is equalized, resulting in a plus and minus tolerance of 1 cps. at the 10-megacycle (center) frequency. Then, lock controls FINE FREQ. ADJUST R 952, R 950 and R 951.

NOTE

An example of step (H) may result in the following:

10,000,001.3 cps.

10,000,000.3 cps.

9,999,999.3 cps.

(i) Disconnect and remove 47-ohm resistor connected in step (a) and counter from 10 MC jack J 905.

D. ABSOLUTE 1-MC FREQUENCY ADJUSTMENT - The absolute 1-mc frequency adjustment procedure is used to tune the internal frequency standard Y 901 to an absolute value of 1 mc, with a stability and accuracy of 1 part in 10^9 . This adjustment is performed only after the coarse and fine linearity adjustments (paragraph 5-5c) have been completed.

(1) Set METER FUNCTION switch S 901 to 24V. Meter M 901 should indicate 24 volts.

(2) Make certain that FINE FREQ. ADJUST control R 952 is centered and locked at zero.

(3) Set METER FUNCTION switch S 901 to 1 MC. Function meter M 901 should indicate a minimum of 1 volt rms.

(4) Connect coaxial cable between 1 MC AMPLIFIER OUTPUTS jack J 907 and TEST IN jack on Precision Frequency Comparator.

(5) Using a reference frequency standard with a known accuracy of 1 part in 10^{10} connect coaxial cable between 1 MC OUT jack on standard and REF IN jack on Precision Frequency Comparator.

(6) On Precision Frequency Comparator, perform the following:

(a) Set MULTIPLIER (M) switch to PARTS IN 10^9 .

(b) Set METER SCALE switch to 1.

(c) Set POWER switch to ON.

(d) Set RECORDER switch to ON.

(7) On Precision Frequency Comparator, observe movement of recorder chart with subsequent recorder pen markings on recorder chart. Markings on recorder chart should be on scale (within + 1 part in 10⁹). Record and observe readings, for a period of 24 hours. If recorder markings continuously remain on scale for 24 hours, proceed to step (11). If not, proceed to step (8).

(8) Remove screw on rear of internal frequency standard Y 901 in order to gain access to 1-mc trimmer control.

(9) Adjust 1-mc trimmer control on internal frequency standard until recorder pen markings on recorder chart are centered at zero (mid-scale).

(10) Allow recorder chart to run for a period of 24 hours. If recorder markings continuously remain on scale for 24 hours, proceed to step (11). If not, repeat steps (9) and (10).

(11) On Precision Frequency Comparator set MULTIPLIER (M) switch to PARTS IN 10⁷. Recorder pen markings should be centered at zero.

(12) Observe and record setting of FINE FREQ. ADJUST control R 952. Unlock FINE FREQ. ADJUST control R 952 and adjust control in a clockwise direction until recorder pen indicates full-scale deflection. Then record number of divisions on FINE FREQ. ADJUST control R 952.

(13) Adjust FINE FREQ. ADJUST control in a counterclockwise direction until recorder pen indicates full scale deflection. Then, record number of divisions on FINE FREQ. ADJUST control R 952. The number of divisions recorded in steps (12) and (13) should be equal. If not, it may be necessary to perform the coarse and fine frequency linearity adjustments (paragraph 5-4c).

(14) On Precision Frequency Comparator, set POWER and RECORDER switches to lower (off) position.

(15) Disconnect coaxial cables connected in steps (4) and (5).

(16) Replace screw on rear of internal frequency standard.

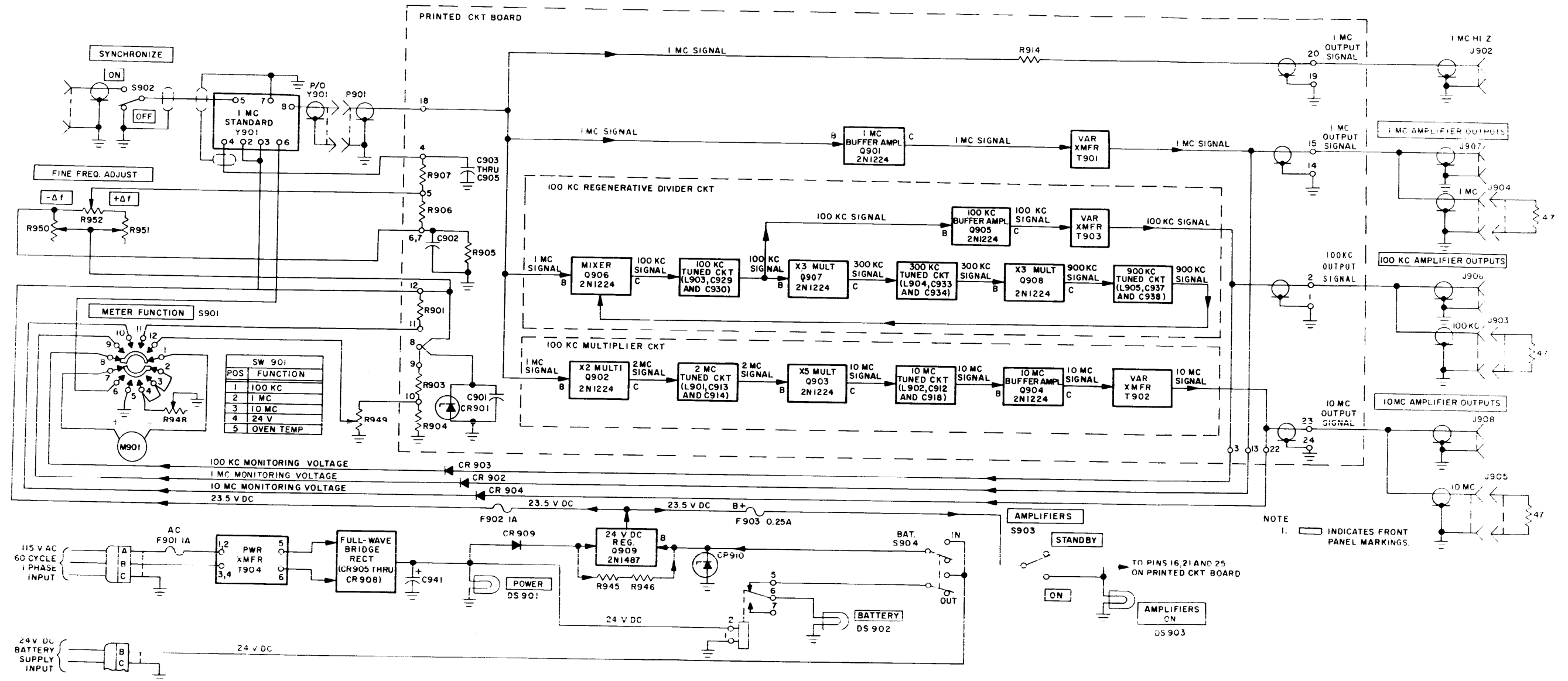

Figure 5-3. CSS Frequency Standard, Service Block Diagram

004666005

SECTION 6 PARTS LIST

6-1. INTRODUCTION.

The parts list presented in this section is a cross-reference list of parts identified by a reference designation and TMC part number. In most cases, parts appearing on schematic diagrams are assigned reference designations in accordance with MIL-STD-16. Wherever practicable, the reference designation is marked on the equipment, close to the part it identifies. In most cases, mechanical and electromechanical parts have TMC part number stamped on them.

To expedite delivery when ordering any part, specify the following:

a. Generic name.

b. Reference designation.

c. TMC part number.

d. Model and serial numbers of the equipment containing the part being replaced; this can be obtained from the equipment nameplate.

For replacement parts not covered by warranty (refer to warranty sheet in front of manual), address all purchase orders to:

The Technical Materiel Corporation
Attention: Sales Department
700 Fenimore Road
Mamaroneck, New York

REF SYMBOL	DESCRIPTION	TMC PART NUMBER
AT901	DUMMY LOAD, ELECTRICAL: 47 ohms, $\pm 10\%$; 1/2 watt; twist lock; BNC type.	DL100-4
AT902	Same as AT901.	
AT903	Same as AT901.	
*AT904	ATTENUATOR: consists of two 47 ohm resistors and one 5000 ohm resistor; with two connectors UG604/U; metal case enclosure.	A3983
C901	CAPACITOR, FIXED, CERAMIC DIELECTRIC: 220,000 uuf, $+80\%$ - 20% ; 10 WVDC.	CC100-33
C902	Same as C901.	
C903	CAPACITOR, FIXED, ELECTROLYTIC: tantalum; 50 uf, $+50\%$ - 15% ; 60 WVDC; polarized; tubular case.	CE107-1
C904	Same as C903.	
C905	CAPACITOR, FIXED, CERAMIC DIELECTRIC: 1,000 uuf; GMV; 500 WVDC.	CC100-29
C906	CAPACITOR, FIXED, CERAMIC DIELECTRIC: 20,000 uuf; $+60\%$ - 40% ; 150 WVDC.	CC100-35
C907	CAPACITOR, FIXED, MICA DIELECTRIC: 330 uuf, $\pm 5\%$; 500 WVDC; char. F.	CM15F331J
C908 thru C910	Same as C906.	

All items marked * shall be used only in the LRRRA-1 system.

PARTS LIST (CONT)

REF SYMBOL	DESCRIPTION	TMC PART NUMBER
C911	Same as C905.	
C912	Same as C906.	
C913	CAPACITOR, FIXED, MICA DIELECTRIC: 360 uuf, $\pm 5\%$; 500 WVDC; char. F.	CM15F361J
C914	CAPACITOR, FIXED, MICA DIELECTRIC: 2,000 uuf, $\pm 2\%$; 500 WVDC; straight wire leads.	CM112E202G5S
C915	Same as C906.	
C916	Same as C906.	
C917	CAPACITOR, FIXED, MICA DIELECTRIC: 300 uuf, $\pm 5\%$; 500 WVDC; char. F.	CM15F301J
C918	CAPACITOR, FIXED, MICA DIELECTRIC: 1,000 uuf, $\pm 2\%$; 500 WVDC; straight wire leads.	CM112F102G5S
C919	Same as C906.	
C920	Same as C906.	
C921	CAPACITOR, FIXED, MICA DIELECTRIC: 270 uuf, $\pm 5\%$; 500 WVDC; char. F.	CM15F271J
C922	Same as C906.	
C923	Same as C906.	
C924	Same as C901.	
C925	Same as C906.	
C926	CAPACITOR, FIXED, CERAMIC DIELECTRIC: 4,700 uuf; GMV; 500 WVDC.	CC100-14
C927	CAPACITOR, FIXED, MICA DIELECTRIC: 5,100 uuf, $\pm 10\%$; 300 WVDC; straight wire leads.	CM112E512K3S
C928	Same as C906.	
C929	Same as C927.	
C930	CAPACITOR, FIXED, MICA DIELECTRIC: 10,000 uuf, $\pm 5\%$; 100 WVDC; straight wire leads.	CM112E103J1S
C931	Same as C906.	
C932	Same as C906.	
C933	CAPACITOR, FIXED, MICA DIELECTRIC: 510 uuf, $\pm 5\%$; 500 WVDC; char. F.	CM15F511J
C934	CAPACITOR, FIXED, MICA DIELECTRIC: 6,200 uuf, $\pm 10\%$; 300 WVDC; straight wire leads.	CM112E622K3S
C935	Same as C906.	
C936	Same as C926.	

PARTS LIST (CONT)

REF SYMBOL	DESCRIPTION	TMC PART NUMBER
C937	CAPACITOR, FIXED, MICA DIELECTRIC: 200 uuf, $\pm 5\%$; 500 WVDC; char. F.	CM15F201J
C938	Same as C927.	
C939	Same as C926.	
C940	Same as C926.	
C941	CAPACITOR, FIXED, ELECTROLYTIC: 1,700 uuf, -10% $+75\%$; 75 WVDC; 100 volts DC surge; plain aluminum case, uninsulated.	CE112-2
C942	Same as C903.	
C943	Same as C926.	
C944	CAPACITOR, FIXED, ELECTROLYTIC: 200 uuf, -10% $+150\%$ at 120 cps, at 25°C ; 15 WVDC; polarized; insulated tubular case.	CE105-200-15
C945 thru C947	Same as C944.	
CR901	SEMICONDUCTOR DEVICE, DIODE: silicon; Zener; 8.4 volts nominal; operating temperature range -55°C to 150°C .	1N3157A
CR902	SEMICONDUCTOR DEVICE, DIODE: germanium; max. peak reverse voltage 200 V; max. continuous forward current. 5 amps at 25°C ; two axial wire lead type terminals; hermetically sealed glass case.	1N39B
CR903	Same as CR902.	
CR904	Same as CR902.	
CR905	SEMICONDUCTOR DEVICE, DIODE: silicon; 100 volts max. peak inverse voltage; 300 ma max. continuous forward current at 150°C ; one solder stud, one 10-32 thd. stud type terminals; hermetically sealed glass case.	1N1582R
CR906 thru CR909	Same as CR905.	
CR910	SEMICONDUCTOR DEVICE, DIODE: silicon; nom. Zener voltage 24 V; standard anode-to-stud polarity, negative-grounded application; tolerance $\pm 5\%$; junction and storage temperature rating -65°C to $+175^{\circ}\text{C}$; power dissipation 10 watts DC; solder terminals; hermetically sealed metal and glass case.	VR101-24-S51
CR911	SEMICONDUCTOR DEVICE, DIODE: silicon; nominal voltage 600 V; max. forward voltage drop 1.0 V; max. continuous DC current .50 amps at 100°C ; peak surge current 75 amps; max. reverse current 1,000 ua; max. operating temperature 150°C ; hermetically sealed.	1N2484

PARTS LIST (CONT)

REF SYMBOL	DESCRIPTION	TMC PART NUMBER
DS901	LAMP, INCANDESCENT: 28 volts; 0.04 amp; miniature bayonet base T-3-1/4 bulb.	BI101-1819
DS902	Same as DS901.	
DS903	Same as DS901.	
F901	FUSE, CARTRIDGE: 1 amp; time lag; 1-1/4" long x 1/4" dia.; slow blow.	FU102-1.00
F902	Same as F901.	
F903	FUSE, CARTRIDGE: 1/4 amp; time lag; 1-1/4" long x 1/4" dia.; slow blow.	FU102-.250
J901	CONNECTOR, RECEPTACLE, ELECTRICAL: RF; 1 round female contact, straight type; 52 ohms; series BNC to BNC.	UG625*/U
J902 thru J905	Same as J901.	
J906	CONNECTOR, RECEPTACLE, BULKHEAD ELECTRICAL: pressurized; 1-5/16" long; series BNC.	UG657*/U
J907	Same as J906.	
J908	Same as J906.	
J909	NOT USED.	
J910	CONNECTOR, RECEPTACLE, ELECTRICAL: 3 number 16 male contacts; straight type.	MS3102A14S-1P
J911	CONNECTOR, RECEPTACLE, ELECTRICAL: 4 number 16 male contacts; straight type.	MS3102A14S-2P
K901	RELAY ARMATURE: DPDT; 700 ohms, $\pm 10\%$ DC resistance; operating voltage 24 VDC; current rating 35 ma, 700 mw at 25°C; contacts rated for 5 amps at 29 VDC; clear high impact styrene dust cover case.	RL156-1
L901	COIL, RF, ADJUSTABLE: 16-28 uh, $\pm 10\%$; 2 ohms DC resistance; perma-torq slug lock type.	CL283-5
L902	COIL, RF, ADJUSTABLE: .87 - 1.3 uh, .084 ohms DC resistance; DC current rating 635 ma.	CL337-1
L903	COIL, RF, ADJUSTABLE: 440 - 800 uh, $\pm 10\%$; 11 ohms DC resistance; perma-torq slug lock type.	CL283-10
L904	Same as L903.	
L905	COIL, RF, ADJUSTABLE: 120 - 243 uh, $\pm 10\%$; 6 ohms DC resistance; perma-torq slug lock type.	CL283-8
L906	COIL, RADIO FREQUENCY: fixed; 100 uf, $\pm 5\%$; 2.6 ohms DC resistance; current rating 345 ma; molded case.	CL275-101

PARTS LIST (CONT)

REF SYMBOL	DESCRIPTION	TMC PART NUMBER
L907 thru L910	Same as L906.	
M901	METER, ARB SCALE: movement- 0 - 50 ua; approx. resistance 2,000 ohms; 0 - 3 scale calibration; rectangular metal case.	MR177
P901	CONNECTOR, PLUG, ELECTRICAL: RF; 1 round female coaxial contact; straight type; miniature bayonet lock series. Part of W901.	PL204
*P902	CONNECTOR, PLUG, ELECTRICAL: accommodates RG174/U coaxial cable; one male pin type contact rated at 500 volts peak; bayonet polarization; twist lock; 50 ohms nom. impedance; BNC crimp type.	PL244-1
*P903	Same as P902.	
Q901	TRANSISTOR: PNP germanium drift field; collector-base voltage -40 VDC, emitter-base voltage -0.5 VDC, collector and emitter current 10 ma; storage temperature -65°C to +100°C; input resistance 150 ohms at 12.5 Mc, output resistance 4,000 ohms at 12.5 Mc; hermetically sealed metal and glass case.	2N1224
Q902 thru Q908	Same as Q901	
Q909	TRANSISTOR: high-power; collector-base voltage 60 VDC, emitter-base voltage 10 VDC, collector current 6 amps, emitter current -8 amps, base current 3 amps; operating and storage temperature -65°C to +200°C; pin type; hermetically sealed metal and glass case.	2N1487
R901	RESISTOR, FIXED, FILM: 590,000 ohms, ±1%; rated at 1/4 watt, 300 WVDC.	RN60D594F
R902	RESISTOR, FIXED, COMPOSITION: 820 ohms, ±10%; 1/2 watt.	RC20GF821K
R903	RESISTOR, FIXED, COMPOSITION: 8,200 ohms, ±5%; 1/2 watt.	RC20GF822J
R904	RESISTOR, FIXED, COMPOSITION: 390 ohms, ±5%; 1/2 watt.	RC20GF391J
R905	RESISTOR, FIXED, COMPOSITION: 470 ohms, ±5%; 1/2 watt.	RC20GF471J
R906	RESISTOR, FIXED, COMPOSITION: 6,800 ohms, ±5%; 1/2 watt.	RC20GF682J
R907	RESISTOR, FIXED, COMPOSITION: 470,000 ohms, ±5%; 1/2 watt.	RC20GF474J
R908	RESISTOR, FIXED, COMPOSITION: 47,000 ohms, ±5%; 1/2 watt.	RC20GF473J

All items marked * shall be used only in the LRRA-1 system.

PARTS LIST (CONT)

REF SYMBOL	DESCRIPTION	TMC PART NUMBER
R909	RESISTOR, FIXED, COMPOSITION: 120 ohms, $\pm 5\%$; 1/2 watt.	RC20GF121J
R910	RESISTOR, FIXED, COMPOSITION: 2,200 ohms, $\pm 5\%$; 1/2 watt.	RC20GF222J
R911	RESISTOR, FIXED, COMPOSITION: 82,000 ohms, $\pm 5\%$; 1/2 watt.	RC20GF823J
R912	RESISTOR, FIXED, COMPOSITION: 1,000 ohms, $\pm 10\%$; 1/2 watt.	RC20GF102K
R913	RESISTOR, FIXED, COMPOSITION: 75 ohms, $\pm 5\%$; 1/2 watt.	RC20GF750J
R914	Same as R912.	
R915	Same as R912.	
R916	RESISTOR, FIXED, COMPOSITION: 10,000 ohms, $\pm 10\%$; 1/2 watt.	RC20GF103K
R917	Same as R902.	
R918	RESISTOR, FIXED, COMPOSITION: 15,000 ohms, $\pm 5\%$; 1/2 watt.	RC20GF153J
R919	RESISTOR, FIXED, COMPOSITION: 1,500 ohms, $\pm 10\%$; 1/2 watt.	RC20GF152K
R920	RESISTOR, FIXED, COMPOSITION: 3,300 ohms, $\pm 5\%$; 1/2 watt.	RC20GF332J
R921	RESISTOR, FIXED, COMPOSITION: 33,000 ohms, $\pm 5\%$; 1/2 watt.	RC20GF333J
R922	RESISTOR, FIXED, COMPOSITION: 68 ohms, $\pm 5\%$; 1/2 watt.	RC20GF680J
R923	RESISTOR, FIXED, COMPOSITION: 220 ohms, $\pm 10\%$; 1/2 watt.	RC20GF221K
R924	Same as R908.	
R925	Same as R908.	
R926	Same as R905.	
R927	RESISTOR, FIXED, COMPOSITION: 100 ohms, $\pm 10\%$; 1/2 watt.	RC20GF101K
R928	Same as R912.	
R929	Same as R916.	
R930	Same as R921.	
R931	RESISTOR, FIXED, COMPOSITION: 4,700 ohms, $\pm 5\%$; 1/2 watt.	RC20GF472J
R932	Same as R912.	

PARTS LIST (CONT)

REF SYMBOL	DESCRIPTION	TMC PART NUMBER
R933	Same as R931.	
R934	Same as R921.	
R935	RESISTOR, FIXED, COMPOSITION: 2,200 ohms, $\pm 10\%$; 1/2 watt.	RC20GF222K
R936	Same as R912.	
R937	Same as R916.	
R938	Same as R916.	
R939	Same as R921.	
R940	RESISTOR, FIXED, COMPOSITION: 330 ohms, $\pm 10\%$; 1/2 watt.	RC20GF331K
R941	Same as R912.	
R942	RESISTOR, FIXED, WIREWOUND: 15 ohms, $\pm 1\%$; 20 watts.	RE75G15R0
R943	RESISTOR, FIXED, COMPOSITION: 680 ohms, $\pm 10\%$; 2 watts.	RC42GF681K
R944	RESISTOR, FIXED, COMPOSITION: 820 ohms, $\pm 10\%$; 2 watts.	RC42GF821K
R945	RESISTOR, FIXED, COMPOSITION: 56 ohms, $\pm 10\%$; 2 watts.	RC42GF560K
R946	RESISTOR, FIXED, WIREWOUND: 100 ohms; current rating 223 ma; 5 watts.	RW107-18
R947	Same as R946.	
R948	RESISTOR, VARIABLE, COMPOSITION: 100,000 ohms, $\pm 10\%$; 2 watts; taper A.	RV4LAYS104A
R949	RESISTOR, VARIABLE, COMPOSITION: 1,000 ohms, $\pm 10\%$; 2 watts; taper A.	RV4LAYS102A
R950	RESISTOR, VARIABLE, COMPOSITION: 2,500 ohms, $\pm 10\%$; 2 watts; taper A.	RV4LAYS252A
R951	RESISTOR, VARIABLE, COMPOSITION: 25,000 ohms, $\pm 20\%$; 2 watts; taper A.	RV4LAYS253B
R952	RESISTOR, VARIABLE, COMPOSITION: 10,000 ohms, $\pm 3\%$; 3 watts; 360° rotation.	RA110-1
R953	Same as R907.	
R954	Same as R942.	
S901	SWITCH, ROTARY: 1 section, 5 positions, non-shorting type contacts; 1 amp at 28 VDC or 5 amps at 110 VAC.	SW107
S902	SWITCH, TOGGLE: SPDT; 6 amps, 125 VAC; 28° angle of throw, solder lug terminals.	ST12D

PARTS LIST (CONT)

REF SYMBOL	DESCRIPTION	TMC PART NUMBER
S903	SWITCH, TOGGLE: SPST; 6 amps, 125 VAC; 28° angle of throw, solder lug terminals.	ST12A
S904	SWITCH, TOGGLE: DPDT; 6 amps, 250 VAC; 28° angle of throw, solder lug terminals, (one pole unused).	ST22N
T901	TRANSFORMER ASSEMBLY, RADIO FREQUENCY: tuned; primary inductance 61 - 122 uh range, frequency 2.5 Mc; secondary inductance near zero ohms.	A3617-1
T902	TRANSFORMER ASSEMBLY RADIO FREQUENCY: tuned; primary inductance .87 - 1.3 uh range, frequency 25 Mc; secondary inductance near zero ohms.	A3616-1
T903	TRANSFORMER ASSEMBLY, RADIO FREQUENCY: tuned; primary inductance 440 - 800 uh range, frequency 790 Kc; secondary inductance near zero ohms.	A3617-2
T904	TRANSFORMER, POWER, STEP-DOWN: primary- 115/230 VAC, 50/60 cps; secondary- 67 VAC at 1.2 amps (intermittent), 0.9 amps (continuous), at input to filter, hermetically sealed.	TF274
W901	WIRING HARNESS, BRANCHED, ELECTRICAL: c/o various lengths and colors of MWC wire, RG174/U cable, insulation, clamps, insulated terminal lugs and one connector symbol no. P901.	CA880
*W902	CABLE, ASSEMBLY, ELECTRICAL: consists of 2 ea. PL244-1, sym no's P902, P903; 6" of RG174/U, cable R. F.	CA480-3-6
XDS901	LIGHT, INDICATOR: with green frosted lens; for miniature bayonet base T-3-1/4 bulb.	TS106-3
XDS902	LIGHT, INDICATOR: with red frosted lens; for miniature bayonet base T-3-1/4 bulb.	TS106-1
XDS903	Same as XDS902.	
XF901	FUSEHOLDER: extractor post type; accommodates cartridge fuse 1-1/4" long x 1/4" dia.; rated at 15 amps, 250 volts max.; o/a length 1-3/4"; bushing mounted.	FH103
XF902	FUSEHOLDER: clip type; single pole; accommodates 1/4" dia. x 1-1/4" long AGC fuse.	FH105
XF903	Same as XF901.	
XF901	SOCKET, RELAY: with retainer; 6 contacts, solder type terminals; black phenolic socket.	TS171-1
XQ901 thru XQ908	NOT USED.	
XQ909	SOCKET, SEMICONDUCTOR DEVICE: 2 pin contact accommodation, .040" or .050" dia.; polarized; 1 terminal lug grounding strap; o/a dimensions 1-37/64" x 1" max.	TS166-1

All items marked * shall be used only in the LRR-1 system.

PARTS LIST (CONT)

REF SYMBOL	DESCRIPTION	TMC PART NUMBER
Y901	OSCILLATOR, FREQUENCY STANDARD: input voltage to oscillator and oven 24 to 30 VDC, regulated to within 2%; input power to oscillator and oven 20 watts max. ; output voltage across 50 ohms, 1 V rms; harmonic distortion 10%; frequency 1 Mc.	NF113

SECTION 7
SCHEMATIC DIAGRAMS

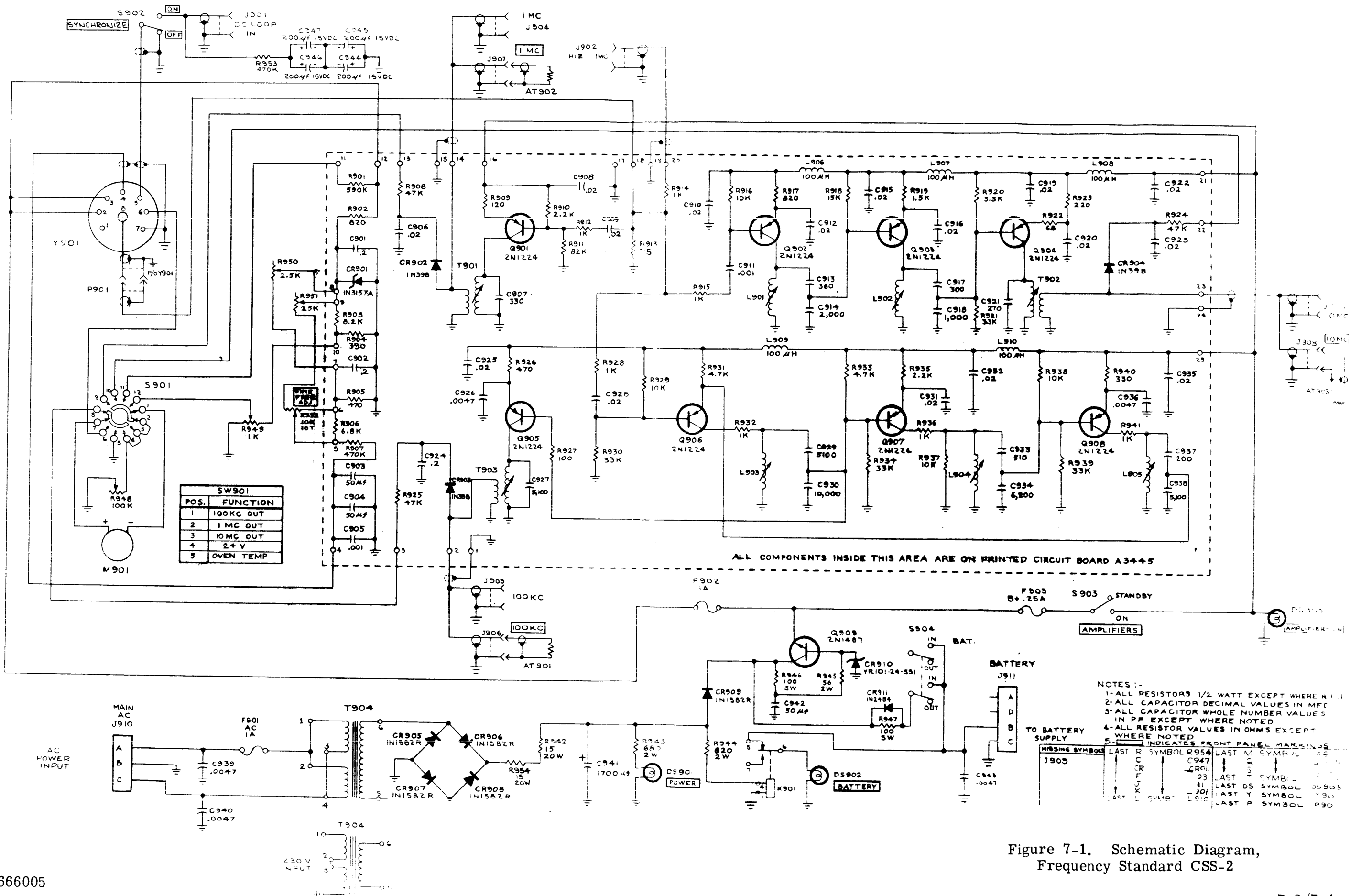

Figure 7-1. Schematic Diagram, Frequency Standard CSS-2