

PART III

TECHNICAL MANUAL FOR CONTROLLED PRECISION OSCILLATOR MODEL CPO-1

(AN/URA-31)

This manual is under preparation; because its material is extensive, it will not be available for several months. In the interim, the following factory check-out procedures, while preliminary, should help field personnel. (When finalized, these procedures will appear in the maintenance section of the CPO manual).

III-6-1: Testing of the SBG System (figure III-6-1)

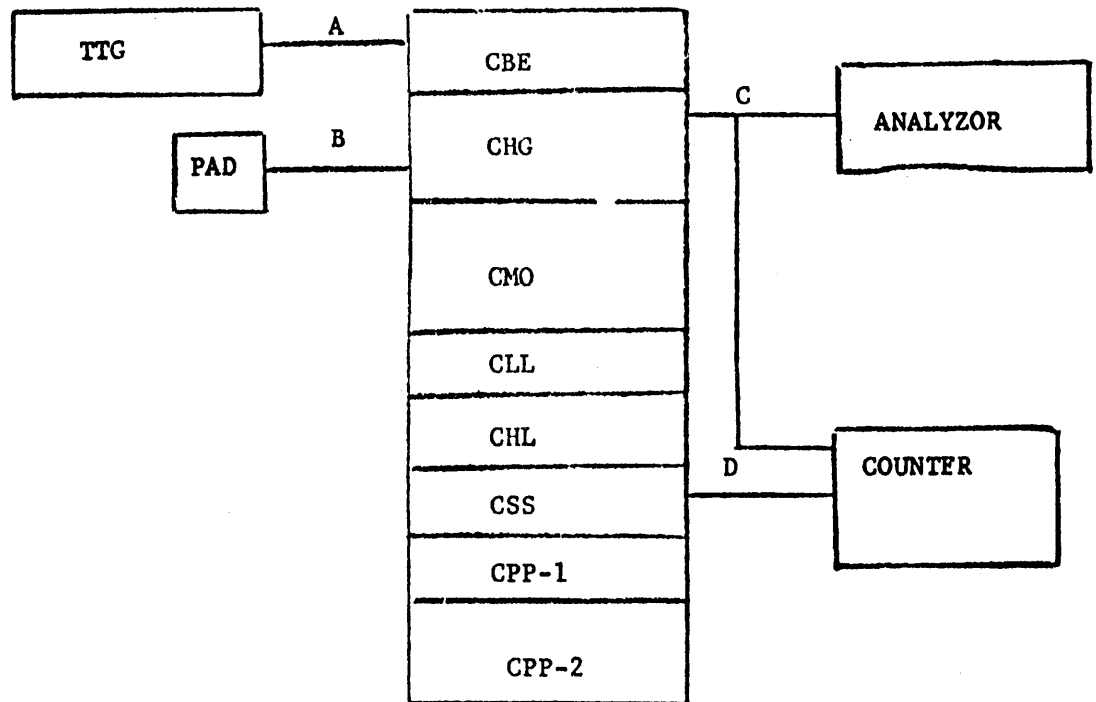

Figure III-6-1: TEST EQUIPMENT SET-UP FOR CPO

1 Test Equipment Required:

- (a) 1 70 ohm, non inductive, 5 watt resistance.
- (b) 1 electronic counter, H.P. 524C or equivalent.
- (c) 1 RF VTVM, H.P. 410B or equivalent.
- (d) 1 Panoramic analyzer Model SB-12A.
- (e) 1 Model TTG, two-tone generator or equivalent.

2 Preliminary:

- (a) Connect RF and power cables to units as shown in CK-468.
- (b) Inspect rack for mechanical imperfections.
 - (1) Insure that cables are free when separate.

- (2) Units should line up in rack together; there should not be any contact between front panel edges.
- (3) Units should slide freely.
- (c) Connect power to rack input J909.
- (d) Set CPP-2 and CHG power switches to "ON". CHG and CMO over lights should be on. Because of the delay tube in the CPP-2, a 60 second wait is necessary before B+ is applied to its associated units. This should be observed.
- (e) CBE and CSS power switches should be turned to their "ON" positions.
- (f) SBG system should have at least a 36 hour warm-up period before testing. This will allow ovens to warm-up and cycle.

AT A: Supply a two-tone audio from TTG to channel 1 or channel 2 to the CBE. A single conductor shielded wire can be used for this purpose. TTG connections are as follows: Shield of wire to terminal 2 or E 500, audio out strip, E 500. The remaining end of the shielded wire should be connected to the CBE in the following manner. For channel 1, connect shield of wire to terminals 1 and 2 of E 201. Insulated wire should be connected to terminal 4. For channel 2, connect shield of wire to terminals 8 and 9. Insulated wire should be connected to terminals 6.

Either one of the two channels can be used. A check should be made, with the channel that is not going to be used throughout the complete frequency test, with at least one of the test frequencies. This is to insure that the channel is functioning properly, and the channel switch is wired properly.

AT B: CHG J-1104 output connected to load.

AT C: CHG J-1105 monitor connected to analyzer and counter signal input connectors.

AT D: CSS J-1602 IMC out to counter frequency standard input; set counter standard switch to external. This is to eliminate any error in the output frequency readout on the counter due to a difference in frequency between the SBG standard (CSS) and the standard in the counter.

3. GENERAL CHECK-OUT

This can only be accomplished by the completion of a 24 hour warm-up.

- (a) Observe if ovens are cycling in CMO and CHG (i.e. oven lights should go on and off).
- (b) The CMO drive control should be turned approximately mid-range. This is to prevent pinning the CHG MF meter.
- (c) A square should appear on the scope in the L-1, L-2, and L-3 positions of the CLL. This should be true for all the positions on the KCS and CPS switches.
- (d) The CHG sync indicator light should remain on in each of the band switch positions.
- (e) Connect test equipment as shown in Figure III-6-1.
- (f) Set CMO counter dial to 1750 KCS, function switch in calibrated position. Beat should be observed on calibrate indicator light. If not, alignment of the oscillator ends is necessary.

(1) OSCILLATOR ALIGNMENT

- a. Set CMO counter to 1750 KCS. 1750 KCS should be approached from the lower frequency side (i.e. 1650 KCS to 1750 KCS). This will prevent any error due to backlash.
- b. Rotate calibrate indicator light is observed. As an additional check, the output of the CMO through a 20 db pad, can be read on the counter.
- c. Set CMO counter to 3750 KCS. Again, as in the 1750 KCS case, 3750 KCS should be approached from the lower frequency side (i.e. 3650 KCS to 3750 KCS).
- d. Rotate MO "High End" trimmer until beat on calibrate

Note the read out on the counter. It can be seen in the Test Equipment set-up, figure 1, that the CSS is also used as the standard for the counter. Therefore, any error in the counter read-out is due to the CSS IMC STANDARD.

- (8) With the output control fully clockwise, the output voltage across the 70 ohm load should be 8.5 volts or better

5. DISTORTION TEST

- (a) Analyzer adjustment for measuring distortion.
- (1) Gain- full clockwise position.
 - (2) Amplitude scale switch-LOG.
 - (3) Cal. OSC level-OFF.
 - (4) Input Attenuator-OFF.
 - (5) I.F. Attenuation-20 db.
 - (6) Sweep width selector-10KC.
 - (7) AFC-OFF.
 - (8) The VOX should be set at 500 KC above the frequency being measured. In the case of the example, 12,751,200 cycles, the VOX frequency should be set at approximately 13,251,200 cycles.
- (b) Distortion measurements should be taken at the frequencies indicated on Chart 1. In each case, the distortion products must be at least 40 db down on two tone test.

6. SPURIOUS

- (a) Set CBE channels to "OFF". Carrier should be inserted to maximum of (0) zero position.
- (b) Analyzer sweep should be set on 500 cycles.
- (c) Distortion measurements should be taken at the frequencies indicated on Chart 1. In each case, spurious should be down 60 db or better.
- (d) It is important that the spurious check should be made through the complete lock-in range of the CMO.

7. CARRIER SUPPRESSION

- (a) Set analyzer IF attenuator to the 20 db position.
- (b) With the carrier adjusted as above, set the carrier representation on the analyzer screen to the (0) zero dB line.
- (c) Switch IF attenuator to (0) zero db position.
- (d) Carrier should be down 55 db or better.

8. SIDE BAND CHECK

- (a) Set carrier to OFF position.
- (b) TTG AUDIO TONE SELECTOR set to TONE 1 position.
- (c) Set CBE USB switch to channel 1 or 2 depending on terminal connections to E 201, LSB Switch to OFF.
- (d) Read frequency on counter.
- (e) Set CBE KSB switch to channel 1 or 2 depending on terminal connections to E 201, USB switch to OFF.
- (f) Read frequency on counter. This frequency should be 1870 CPS lower than first, reading it a 935 CPS tone is used from the TTG. If this second reading is not lower in frequency, check for proper filter placement in the CBE or cable connections.

CHART 1

TEST FREQUENCIES			BAND SW. NO.	Output tuning Dial Band
1.750	2.750	3.750	0	A
3.750	4.750	5.750	2	B
	4.000		2	B
	5.000		2	B
5.750	6.750	7.750	4	C
7.750	8.750	9.750	6	C
9.750	10.750	11.750	8	C
11.750	12.750	13.750	10	C
13.750	14.750	15.750	12	D
15.750	16.750	17.750	14	D
17.750	18.750	19.570	16	D
19.750	20.750	21.750	18	D
21.750	22.750	23.750	20	D
23.750	24.750	25.750	22	D
25.750	26.750	27.750	24	D
27.750	28.750	29.750	26	D
29.750	30.750	31.750	28	D
31.750	32.750	33.750	30	D

III-6-2. Test Procedure for Regenerative Divider Section of CHG-1

(figure III-6-2).

1. FUNCTION & DESCRIPTION

- (a) The function of the Regenerative Divider is to convert a 1 Mc standard signal into a standard 250 Kc source for the operation of the CBE. This is accomplished by tuning the plate circuit of the 6U8 triode (pin 1) to the 750Kc component of the noise spectrum present in the tube. This 750Kc signal is then fed to the signal grid of the mixer tube, 6BE6 pin 7, where it beats with the 1 Mc input signal thereby generating a 250Kc signal which is tuned in the mixer Plate circuit and then fed into the output pentode stage of the 6U8 where it is further amplified and fed to an output jack. (J1602).

2. Test Equipment Required:

- (a) Oscilloscope, Tektronics Type 545 A.
 (b) Signal Generator, Measurements Model 82.
 (c) R.F. Voltmeter, Hewlett-Packard 41 OB.
 (d) Power Supply, Lambda Model 25 and Cable Ass'y.
 (e) Multimeter, Simpson #260 or equivalent.
 (f) Pulse Transformer (10:1 step up) cable assembly.

3. D.C. VOLTAGE

- (a) Inspect unit carefully. See if unit is clear of short circuits loose parts, etc.
 (b) Check B+ line pin H of J1603 to ground with ohm meter--reading should be infinite.
 (c) Connect to power supply through power cable ass'y.
 (d) Connect 68 ohm $\frac{1}{2}$ W. load across output jack J1602.
 (e) Turn AC on set DC output voltage to 200V, then turn DC switch on.
 (f) Measure D.C. voltages as per chart voltages should be within \pm 10%.

D.C. VOLTAGE CHART

SYMB.	TYPE	1	2	3	4	5	6	7	8	9
V1601	6BE6	-2	+1.7	6.3 AC	0	+170	+85	(approx) 0		
V1602	6U8	+195*	6 app.	+50V	6.3 AC	0	+200V	+0.8V	+5.3	0

*This voltage varies with the noise present in tube, by pass plate pin 1 with .01 Mf. capacitor to obtain voltages shown.

3. ALIGNMENT

- (a) 750Kc circuit, L1602
 (1) Connect Signal Generator to Pin 9 of V1602, 6U8 Tube.
 (2) Set Generator frequency to 750Kc. Output to .2V RMS.
 (3) Connect Oscilloscope to pin 1 of V1602 6U8 Tube.
 (4) Tune L1602 for maximum output on oscillograph (1.8V PP Approx).
 (b) 250Kc. CIRCUIT L1601
 (1) Connect Signal Generator to input, J1601.
 (2) Set Generator frequency to 250Kc. Output to 50MV RMS
 (3) Connect Oscilloscope to pin 5 of V1601 6BE6 Tube.
 (4) Tune L1601 for maximum output on Oscilloscope, 3.3V PP Approx.
 (c) Final Alignment and Gain Measurement
 (1) Connect Signal Generator through 10:1 step-up transformer and cable assembly to input J1601.

- (2) Set Generator frequency to 1 Mc.
- (3) Set Generator Attenuator to produce 6 volts RMS at J1601.
- (d) Measure with RF Meter.
 - (1) Connect Oscilloscope to output jack J1602 across 68 ohm load,
 - (2) Tune L1603 for maximum output on Oscillography 3.3V PP approx.
 - (3) Retune (touch up) L1601, L1602 L1603 and lock tuning adjustments carefully.
 - (4) Measure output voltage with RF Voltmeter -- output shall be 1 to 1.5V RMS across 68 ohms at J1602.
 - (5) Signal voltages as per table below for reference.

SYMBOL	TYPE	1	2	5	6	7	9	J1602
V1601	6BE6	INPUT 6V		21.5		6.		
V1602	6U8		4.2		17		20	1.2

III-6-3: Test Procedure For Power Supply Unit CPP-1

1. INTRODUCTION

This is a conventional power supply using 4 IN1084's as a full wave rectifier and an OA2 as a voltage regulator.

2. TEST EQUIPMENT REQUIRED

- (a) Multimeter - Simpson 260
- (b) AC V.T.V.M. - Ballantine.

3. PRELIMINARY

- (a) Inspect the unit for mechanical imperfections.
- (b) Inspect for obvious wiring errors.
- (c) Check for B+ shorts with ohm meter. Check for 0 ohm between pin M of J402 and chassis with ohmmeter.
- (d) Check tube, diodes and fuses as to correct kind.
- (e) Attach jumpers between pins E&L, J&M of J402.
- (f) Plug AC cable into outlet.
- (g) I401 should be light now.

4. TESTING OF CPP-1

- (a) Check out voltages at J402.

Voltage at J402 - No Load	
On J 402 Pins	Voltages
A - J	6.3 VAC
B - F	6.3 VAC
D,E - L	115 VAC
G - Ground	150 VDC
H - Ground	210 - 280 VDC
C - N	6.3 VAC
Ripple	Max .002 V

- (b) Should any trouble be experience in the voltages check of J402 then the following points should be checked.

C401	Pin 5	210-280 VDC
C402	Pin 5	210-280 VDC
V402	Pin 1	150 VDC
V402	Pin 5	150 VDC

- (c) If any of these voltages do not appear, check the components concerned.

5. RIPPLE TEST

- (a) Place AC probe of Ballantine of Pin 5 of C402.
- (b) Measure the amount of AC ripple presetn.
No more than .002 V VMS.

III-6-4: Test Procedure For Power Supply CPP-2

1. GENERAL INSPECTION

- (a) Inspect the unit for obvious mechanical errors.
- (b) Inspect the unit for obvious electrical errors.
- (c) Check if CR 501 and CR 502 have been properly inserted.
- (d) Set Voltage Adjust Potentiometer, R 514, approximately in center.

2. Regulation Transformer T 502

- (a) Check all terminal connections at the transformer.
NOTE: For the test purpose it must be wired for 60 cps.
Damage to the transformer will otherwise result.

3. Oven Circuitry

- (a) Place CPP's POWER switch in power position.
- (b) Observe that CMO's OVEN pilot light is lit.

4. 6.3 VDC

- (a) Observe that the following tubes are lit.

<u>Unit</u>	<u>Tube</u>
CHL	V 105 (100 to 10 Kc divider)
CLL	V 708 (510-520 Kc oscillator)
CMO	V 301, V303 (MO and Reactance Tube)

5. 6.3 VAC

- (a) Observe that the remaining tubes in the CHL, CLL and CMO are lit.

6. B+ Voltage Regulation

- (a) If CPP's +160 V (REGULATED) voltage is outside limits (160 ± 4), trouble shoot the CPP's regulating circuit. As a last resort, vary the 115 VAC input voltage with a variac and observe the performance of the regulated voltage.

7. Power Amplifier B+ Voltage

- (a) Connect voltmeter to terminals 8 and 3 at J 502; the voltage must be 200 - 250 VDC.

8. Scope B+ Voltage

- (a) Connect voltmeter to terminals 8 and 3 at J 501; the voltage must be 270 - 400 VDC.

9. Scope B- Voltage

- (a) Connect voltmeter to terminals 5 and 3 at J 501; the voltage must be 400 - 500 VDC.
- (b) Remove Scope fuse, F 504; the voltage must disappear.
- (c) Replace the fuse.

9 A. B- Regulated Voltage

- (a) Connect voltmeter to terminals 4 and 3 at J 501 the voltage must be in the range of 70 - 80 VDC (Usually about 7.3).

10. Scope Filament Voltage

- (a) With AC voltmeter measure voltage between terminals 1 and 2 at J 501. It must be in the range of 6.0 - 7.0 VAC (Usually about 6.4).

11. Ripple Test

- (a) With AC Milli-voltmeter measure following voltages in respect to terminal 3.

Terminal	AC Ripple Voltage (less than)
16	.02 VAC
9	.1 VAC
8	.1 VAC
5	.12 VAC
4	.02 VAC

NO LOAD

	PIN 1	PIN 2	PIN 3	PIN 4	PIN 5	PIN 6	PIN 7	PIN 8
V 501	5.4	380	160	5.4	380	160	6.3 VAC	6.3 VAC
V 502	5.4	380	160	5.4	380	160	6.3 VAC	6.3 VAC
V 503	—	380	—	450	—	450	—	380
				VAC		VAC		
V 504	-1.6	0	6.3	6.3	5.2	160	0	—
			VAC	VAC				
V 505	0	-70	—	-70	0	—	-70	—

FULL LOAD

	PIN 1	PIN 2	PIN 3	PIN 4	PIN 5	PIN 6	PIN 7	PIN 8
V 501	115	300	165	115	300	165	6.3 VAC	6.3 VAC
V 502	115	300	165	115	300	165	6.3 VAC	6.3 VAC
V 503	—	310	—	415	—	415	—	310
				VAC		VAC		
V 504	-3.6	0	6.3	6.3	110	160	0	—
			VAC	VAC				
V 505	0	-70	—	-70	0	—	-70	—

ALL VOLTAGES EXCEPT FILAMENT VOLTAGES MEASURED TO CHASSIS GROUND ALL VOLTAGES ARE +10%.

III-6-5: Test Procedure for Controlled Master Oscillator

CMO-1 or CMO-2

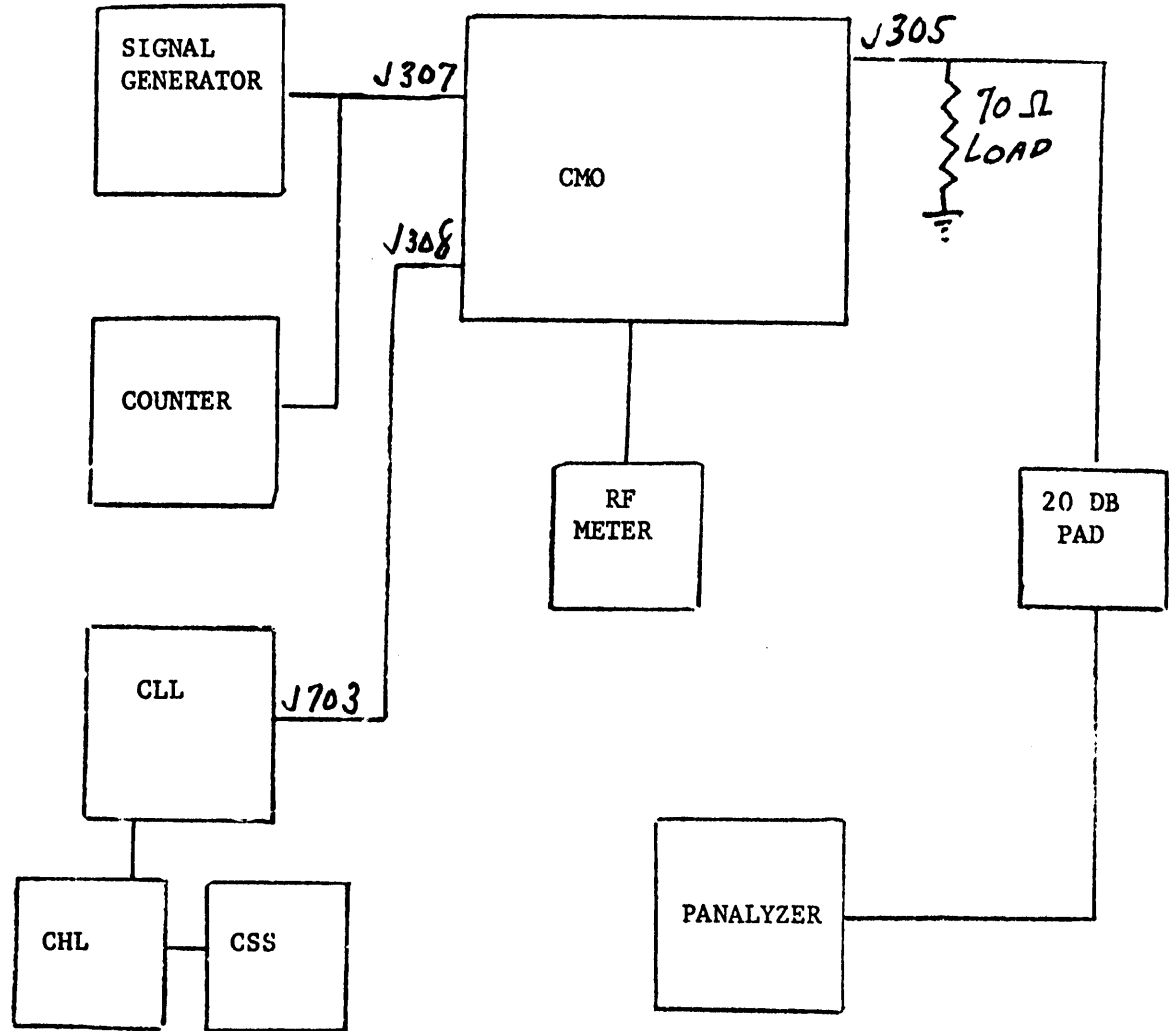

Figure III-6-3: Test Set Up for CMO

1. Test Equipment Required

- (a) 1-RF Generator (Model 82).
- (b) 1-70 ohm, non-inductive, 5 watt resistance
- (c) 1-RF VTVM, H.P. 410B or equivalent.
- (d) 1-Counter, H.P. 524C or equivalent.
- (e) 1-CLL
- (f) 1-CPP-2
- (g) Panalyzor SB-12A.
- (h) 1-CSS
- (i) 1-CHL

2. Preliminary

- (a) Inspect the unit for mechanical imperfections.
- (b) Inspect for obvious wiring errors.
- (c) Check for B+ shorts with ohm meter.
- (d) Attach jumper between pins of E 303.
- (e) Connect 70 ohm load to J 306.
- (f) Check oven heater resistance by placing meter between pins 9 and 10. A reading of approximately 700 ohms should be obtained.
- (g) Attach cable from power supply (CPP-2) to CMO. Turn AC power ON. Oven indicator should light and cycle after approximately 36 hours.
- (h) Measure the DC voltage at C 333, C 337, C 346 and C 328. There should be 160 volts at these points. 220 volts should be measured at C 345.

3. 100 KC Oscillator Calibration

- (a) Set function switch to CAL position and connect counter to pin 1 of V 312.
- (b) Adjust C 311 for a 100,000 cycle reading on the counter. C 311 is coupled to a bakelite shaft in the rear of the shock mount d oven assembly. A slot is provided on the end of this shaft for screw driver adjustment.

4. Testing of the High Frequency Deck

- (a) IF STRIP
 - (1) Remove the 510-519.9 Kc, 10 Kc, and 2-4 Mc inputs from the CMO.
 - (2) Connect the signal generator to pin 2 of V 309. Set the signal generator to 515 Kcs at 1 volt. Connect the RF meter to pin 7 of V 310.
 - (3) Adjust T 308, T 307 and T 306 for maximum amplitude. Voltage should read approximately 11 volts.
 - (4) Remove signal generator from pin 2 of V 309.
- (b) 2 to 4 MC First RF Amplifier (V 304) and Power Amplifier (V 305).
 - (1) Set drive control, R 321, in full clockwise position.
 - (2) Connect the signal generator or MO to J 302.
 - (3) Connect RF meter to J 305 RF out.
 - (4) Set signal generator to 2 Mc at 1 volt.
 - (5) Set Tuning KCS control to the 2 Mc (CMO-2) or 1.750 MC (CMO-1) position (full mesh). Adjust T 301 and T 302 for maximum Amplitude.
 - (6) Set Tuning KCS control to the 4 Mc (CMO-2) or 3.750 Mc (CMO-1) position (full open). Adjust C 329 and C 331 for maximum Amplitude.
 - (7) Repeat steps 5 and 6 until selected signal is at maximum in both positions without further adjustment.
 - (8) Voltage across 70 ohm should be 8.5 volts or better. Output meter should be at approximately 8.
- (c) Harmonic Selector
 - (1) Connect the signal generator to the 10 Kcs input jack, J-307.
 - (2) Connect the counter and RF meter to R 327.
 - (3) Connect the 2-4 Mcs input from MO to J-302 on HF deck.
 - (4) Set trimmers C 332 and C 336 to mid range.

- (5) Set the MO counter and the Tuning KCS control to the 2000 KCS position (full mesh on Tuning KCS capacitor). In the case of the CMO-1, it would be on 1750 KCS.
 - (6) Vary the signal generator around 1.485 mcs at approximately 1 volt until a reading of 515 Kcs is obtained on the counter.
 - (7) Adjust the T 303 and T 304 for maximum amplitude.
 - (8) Set the MO counter and the Tuning KCS control to the 4000 KCS position (full open on Tuning KCS capacitor). In the case of the CMO-1, it would be 3750 KCS.
 - (9) Vary the signal generator around 3.485 mcs at approximately .5 volts until a reading of 515 KCS is obtained on the counter.
 - (10) Adjust C 332 and C 336 for maximum amplitude.
 - (11) Repeat steps 5 through 10 until the selected signal is at maximum in both positions, high and low ends, without further adjustment.
- (d) HF Phase Detector
- (1) Set the tuning kcs control to a frequency differing at least 100 Kcs from the MO frequency. This will insure that the high frequency loop is not synchronized.
 - (2) Remove the MO INPUT (to P 302 or J 302) and adjust R 328 for center scale on the sync meter.
- (e) Sync Indicator
- (1) Connect 10 kcs from the CHL to J 307.
 - (2) Set CLL kcs and cps control to zero position.
 - (3) Set MO to 3 mc (CMO-2) or 2.750 mc (CMO-1) and peak "tune" meter with tuning kcs control.
 - (4) Vary MO control 500 cps above and below 3 mc. The sync meter will follow in the same direction as this control is varied. This indicates that the H.F. loop is sync-ed.
 - (5) With the loop in sync. and the meter in center position, vary R. 340 to the point where I 304, the sync indicator light, ignites.
 - (6) Vary the Mo control 1 Kc above and below 3 mc (i.e. 2999 Kc-3001 Kc). The sync indicator light should remain on, and the sync meter should follow the variation of the MO control.
 - (7) As a final check, vary the MO control slowly 1 Kc above and below 2,3 and 4 mc. As the loop drops out of sync, (sync meter will fall to center scale position) The sync indicator light will go off.
 - (8) Operations (2) through (7) apply when CLL's kcs and cps controls are on zero position; concurrently CMO's frequency control is exactly 3000 (kcs) 0 (cps) for CMO-1 or 2750 (kcs) 0 (cps) for CMO 2. Similar operations should be made when CLL's kcs dial is on 5 position and cps dial is on zero position; concurrently CMO's frequency control is exactly 3500 (kcs) 0 (cps) for CMO-1 or 3250 (kcs) 0 (cps) for CMO-2. Once again, similar operations should be made when CLL's kcs dial is on 9 position and cps dial is on zero position; concurrently CMO's frequency control is exactly 3900 (kcs) 0 (cps) for CMO-1 or 3750 (kcs) 0 (cps) for CMO-2.
- (f) Master Oscillator Alignment
- (1) Set CMO counter to 1750 KCS. 1750 KCS should be approached from the lower frequency side (i.e. 1650 KCS to 1750 KCS). This will prevent any error due to backlash.
 - (2) Rotate calibrate knob until beat on calibrate indicator light is observed. As an additional check, the output of the CMO through a 20 db pad, can be read on the counter.

- (3) Set CMO counter to 3750 KCS. Again, as in the 1750 KCS case, 3750 KCS should be approached from the lower frequency side (i.e. 3650 KCS to 3750 KCS).
 - (4) Rotate MO "High End" trimmer until beat on calibrate indicator light is observed. This trimmer is located behind the front panel hole adjacent knob.
 - (5) Repeat step 1 through 4 until beat is observed at 1750 KCS and 2750 KCS without further adjustment. This completes the oscillator alignment.
- (g) Master Oscillator Calibration
- (1) Without touching either adjustment controls, record the amount of error in the MO dial against the 100 KCS standard at every 100 Kcs point between 2 and 4 Mcs. A form has been provided for this purpose. No unit may be passed where an error exceeds 200 cps.

5. SPURIOUS CHECK

- (a) Connect analyzer as shown in test set-up diagram.
 - (b) Turn drive control, R 321, fully clockwise.
 - (c) Set MO at 2 mcs.
 - (d) Set function switch to calibrate.
 - (e) Adjust tuning kcs control for maximum indication on output meter
 - (f) Panalyzer adjustment for measuring distortion gain-fully clockwise.
- Amplitude scale
 Cal. OSC level-OFF
 I.F. Attenuation-20db
 Sweep width selector-2 kc.
 AFC-OFF
- The VOX should be set at 500 Kc above the frequency being analyzed. In this case, it would be approximately 2500 Kc.
 The output is set at approximately .2 MA.
- (g) Using the "INPUT Attenuator" switches on the analyzer, adjust the amplitude on the screen as close as possible to the zero (0) line, then line adjust it with gain control.
 - (h) Any spurious should be 60-db or more below the carrier.
 - (i) Set function switch to operate position.
 - (j) Sync MO in accordance with section 4-(e).
 - (k) Vary the MO within the boundary of the lock-in range. As this is done observe the analyzer screen. Spurious should be 60-db or more below the carrier.
- (1) A check of D through K should also be made on 3 MC and 4 MC.

III-6-6 Test Procedure for Divider Chain Model CHL-1 (Figure III-6-4)

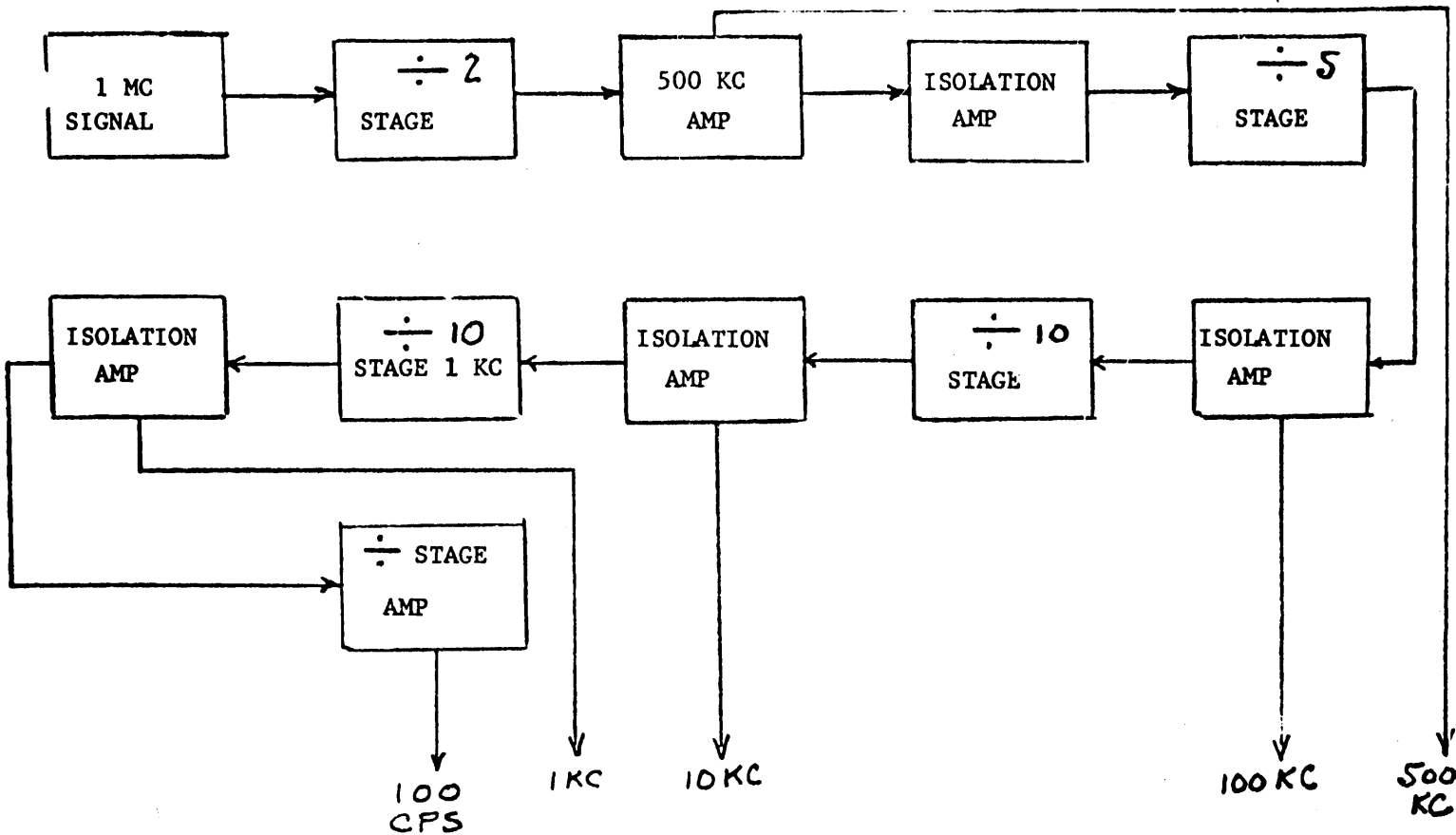

TEST EQUIPMENT NEEDED

1. Regulated power supply (Lambda).
2. 1 Mc source CSS or equivalent.
3. Frequency counter (H.P. 524 C).
4. A.C. VTVM (HP 410B).

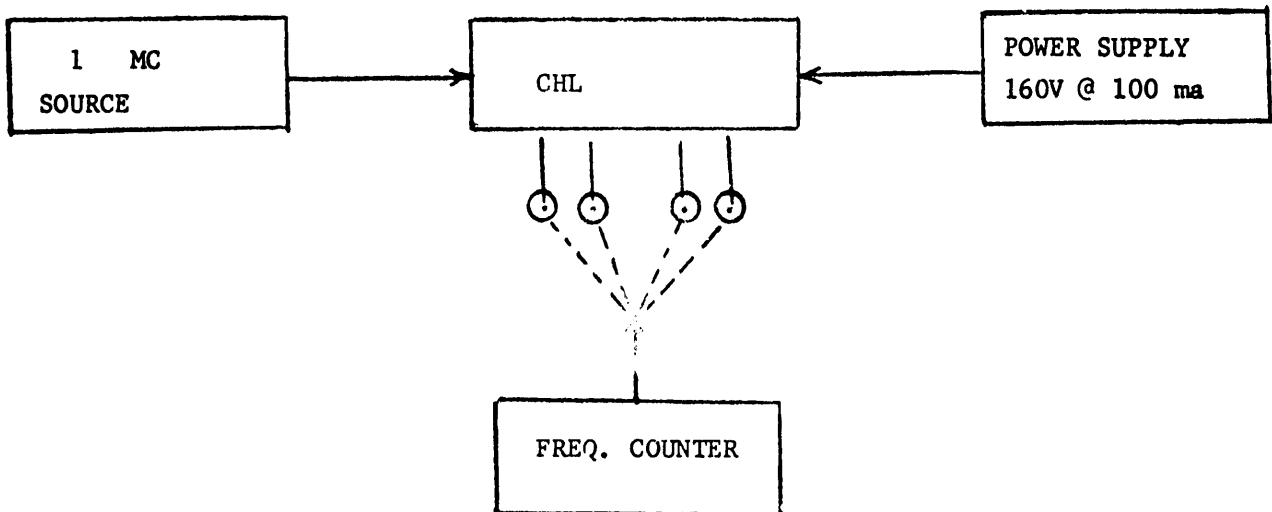

Figure III-6-4 Test Set Up For Divider Chain CHL
III-6-15

1. PROCEDURE

Use a H.P. VTVM (# 410B) or equivalent.

- (a) Set the divider chain as shown in figure 1.
- (b) Adjust the 1 mc input signal to 1.0V at T 101 primary to ground.
- (c) Connect the VTVM and counter to the 500 KC output jack. Tune L 102 for maximum output. Output should be approximately 2- $\frac{1}{2}$ to 3- $\frac{1}{2}$ volts.
- (d) Connect frequency counter at the 100 KC test jack. Adjust R 114 until 100 KC is indicated on the counter.
- (e) Connect frequency counter at the 10 KC test jack. Adjust R 124 until 10 KC is indicated on the counter.
- (f) Connect the frequency counter at the 1 KC test jack. Adjust R 135 until 1 KC is indicated on the counter.
- (g) Connect the frequency counter at 100 cps test point. Adjust R 147 until 100 cps is indicated on the counter.
- (h) NOTE: that no frequency deviation is expected in the alignment procedure. The frequency should be "locked" in at 500 KC, 100 KC, 1 KC and 100 cps. Any deviation in frequency indicates an error in the circuit. A voltage chart is provided for indicating all AC & DC voltages with and without the 1 mc input signal.

VOLTAGE CHARTS

DC VOLTAGE

Without 1 mc Input Signal _____ Ebb = 160V

	PINS	1	2	3	4	5	6	7	8	9
V 102, 5814A, + 2.		141	53	61	0	0	139	53	61	0
V 101A, 6U8, 500 KC Amp.		0	-.9	90	0	0	132	1.35	0	0
$\frac{1}{2}$ V 103A, 5814A Isolation Amp		125	-3.3	0	0	0	-	-	-	0
V 104 5725 + 5.		5.3	8	0	0	125	105	5	None	None
V 103B, 5814A Isolation Amp.		-	-	-	0	0	158	-10.0	68	0
V 105, 5725, +10		4.6	7.7	0	6.3	115	120	5	None	None
V 106A, 5814A Isolation Amp.		-	--	-	0	0	160	-16	.58	0
V 107, 5725, + 10		2.8	7.3	0	0	98	138	5	None	None
V 106B, 5814A, Isolation Amp.		160	-36	.25	0	0	-	-	-	0
V 108, 5725, + 10		1.3	5.7	0	0	90	137	5.5	None	None

VOLTAGE CHARTS

DC VOLTAGE

With 1 mc Input Signal _____ Ebb = 160V

	PINS	1	2	3	4	5	6	7	8	9
V 102 5814 A, + 2		120	61	68	0	0	125	59	68	0
V 101A, 6U8, 500 KC Amp		0	0	110	0	0	109	1.7	0	0
$\frac{1}{2}$ V 103A, 5814A, Isolation Amp		105	-66	0	0	0	-	-	-	0
V 104, 5725, + 5		12	11.8	0	0	159	145	5	None	None
V 103B, 5814A, Isolation Amp		--	-	-	0	0	150	0	2.7	0
V 105, 5725 + 10		14	13.9	0	6.3	159	60	5	None	None
V 106A, 5814A, Isolation Amp		-	-	.	0	0	145	0	2.7	0
V 107, 5725, + 10		19	18.5	0	0	150	75	5.2	None	None
V 106B, 5814A, Isolation Amp		145	0	2.7	0	0	-	-	-	0
V 108, 5725 + 10		14.3	14.2	0	0	156	60	5.3	None	None

VOLTAGE CHART
AC VOLTAGE

PINS	1	2	3	4	5	6	7	8	9	9
V 102, 5814A, -2	8.2	6.2	.12	-	-	8.4	5.8	.12	-	-
V 101A, 6UB, 500 KC Amp	None	1.3	0	-	-	87	.14	none	none	-
½ V 103A, 5814A, Isolation Amp	22	2.2	0	-	-	-	-	-	-	-
V 104, 5725, - 5	10	8.3	-	-	18.5	23.5	.7	none	none	-
V 103, 5814A, Isolation Amp	-	-	-	-	-	1.8	11	3	-	-
V 105, 5725, - 10	16	13.5	-	-	30	19.5	.02	none	none	-
V 106A, 5814A, Isolation Amp	-	-	-	-	-	1.6	16	3	-	-
V 107, 5725, - 10	16	12	-	-	38	14	.32	none	none	-
V 106B, 5814A, Isolation Amp	1.2	32	4.1	-	-	-	-	-	-	-
V 108, 5725, - 10	11.8	8	-	-	52	17.5	.27	none	none	-

NOTE: The filament voltages have been omitted

III-6-7 Test Procedure For Primary Standard Model CSS-1

1. TEST EQUIPMENT REQUIRED

- (a) Counter - 1 MC
- (b) AC VTVM (Heath)
- (c) 70 ohm non inductive resistance

2. PRELIMINARY

- (a) Inspect unit for mechanical imperfection.
- (b) Inspect for obvious wiring errors.
- (c) Check for B+ shorts with ohm meter.
- (d) Check for proper orientation of transistor. Correct wiring (very important)
The index tab on the transistor should match the keyway on the socket.

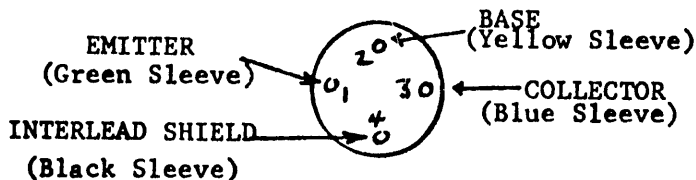

BOTTOM VIEW
TRANSISTOR 2N1224

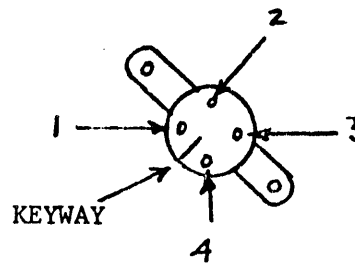

TOP VIEW SOCKET

- (e) Connect 70 ohm load to J 602.
- (f) Make sure that the terminal board is screwed down, otherwise unit will not function.
- (g) Plug unit into AC and check operation of pilot lights I 601 and I 602 are functioning when S 601 is in the respective position.
- (h) Allow a 6-hour warm up period before making the tests in following paragraph 3.

3. TESTING OF CSS-1

- (a) See that there is a minimum of 25 volts dc at the junction of R 618, CR 601 and R 619.
- (b) Turn R 617 "Output Adjust" to maximum output.
- (c) Place probe of VTVM at Pin 6 of Z 602, the voltage at this point should be 2.3 VAC at least.
- (d) Measure the output of T 604 (blue terminal) with the VTVM and tune the slug for a peak reading on the meter .6VAC Min.
- (e) At points B₁ Q 601 and B₂ Q 602, E₁ Q 601 and E₂ Q 60s. These voltages should be the same within .5 volt B₁ & B₂, E₁ & E₂.

If trouble is encountered then the transistor should be checked. The method of checking should be done by substitution. The transistor should not be discarded. If the symptoms still exist after replacement, then the components in the amplifier circuit have to be checked.

- (f) Place probe of VTVM on the output jack (J 602). Tune T 603 for maximum indication on meter.
- (g) Z 601 Place probe on one of the yellow terminals of Z 601. Peak Z 601.
- (h) With R 616 in maximum sensitivity position proceed to balance out Z 601 using R 614 bring the meter (M 601) to center scale reading when this has been accomplished the modulators are balance.
- (i) M 601 If step 8 is correctly performed then with R 616 @ minimum sens: The meter will read) (center Scale).
- (j) The output for the CSS-1 should be 1.0 VAC. (min).

III-6-8 Test Procedure for Low Frequency Loop (Controlled Oscillator) Model CLL-1 (Figure III-6-6).

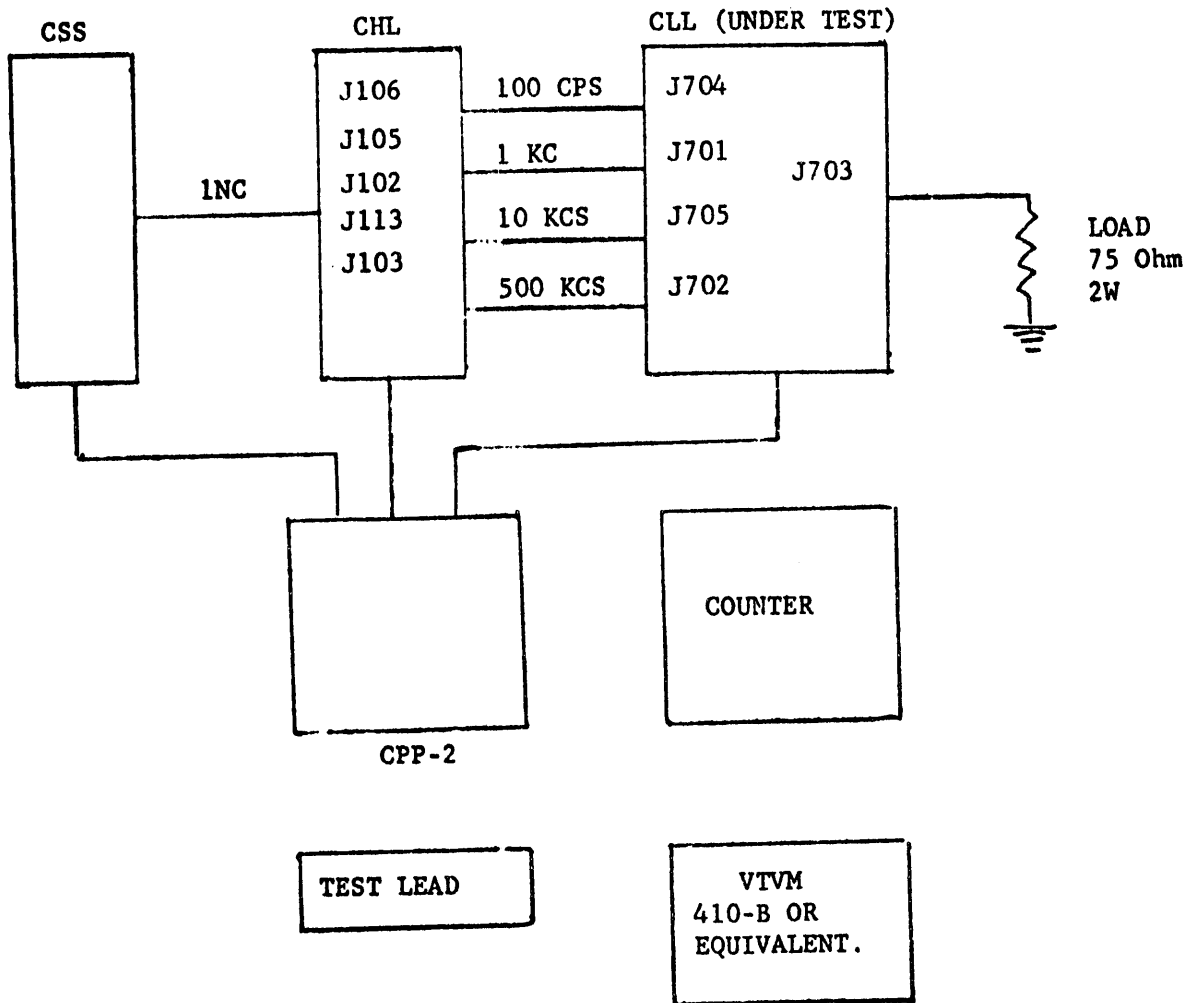

Figure III-6-6: Test Set Up

(NOTE: S also figure I-4-9 for block diagram layout of CLL)

1. GENERAL INSPECTION

- (a) Inspect the unit for obvious mechanical and electrical errors.
- (b) Inspect carefully the 510-520 kcs compartment for shorts and layout of oscillator wires. The solid oscillator wires may not touch the chassis even though they are insulated.
- (c) Check wiring and jumper at E 701. Check oven heaters and thermostat.
- (d) Check switches S 701 and S 702 for proper alignment e.g. The wiper must touch their respective contacts and correspond to the proper position on the detent and dial.
- (e) Replace all covers except top and bottom outer covers.

2. INITIAL CHECK-UP

- (a) Set-up all equipment as shown in figure III-6-6.
- (b) Turn on the power and measure B+. It must be 160 VDC; if not re-adjust R 514 on CPP-2.
- (c) Measure filament voltage V 708; it must be approximately 6.3 VDC (Not AC).
- (d) Using counter check following frequencies:
 - a) AT J 701 1 KCS
 - b) AT J 702 500 KCS
 - c) AT J 704 100 CPS
 - d) AT J 705 10 KCS
- (e) Let the unit warm up for at least 2 hours before proceeding with the rest of the test.

3. SCOPE V-713

- (a) Set scope switch S 703 in position "L-1".
- (b) Adjust intensity R 783 and focus R 781 for optimum operation.
- (c) Adjust deflection controls R 773 and R 774 so that the square will appear approximately in the middle of the screen.
- (d) Set scope switch to position "L-2"; a square must appear.
- (e) Set scope switch to position "L-3"; a square must appear.
- (f) Set scope switch to position "off" there must be no light on the screen.

4. LOW FREQUENCY LOOP, L-1

- (a) Alignment
 - (1) Place the test lead from J 713 (TP7) to ground.
 - (2) Place the hundreds of cycles switch S 702 in position 5.
 - (3) Measure voltage with AC VTVM at J 714 (TP8) it must be 4.6^V
 - (4) Connect counter to J 714 (TP8).
 - (5) Adjust C 815 for 11500 ± 4 cps on the counter and lock C 815.
 - (6) Disconnect counter to J 714 (TP8)
- (b) Phase Detector
 - (1) Set DC VTVM on 3V scale and set zero adj. on VTVM so that the pointer is in the middle of the scale; note the reading e.g. 1.5 V.
 - (2) Connect the DC VTVM to J 711 (TP5).
 - (3) Remove 100 cps input from J 704.
 - (4) Turn balance control R 755 from one extreme to the other; the DC VTVM must follow from at least -1.5 V to + 1.5 V.
 - (5) Adjust balance control R 755 for (zero) 0V. and lock it. (or, as in example in step 6, set to the noted reading e.g. 1.5 V.)
 - (6) Replace 100 cps input to J 704.
 - (7) Remove test lead from J 713 (TP7).
 - (8) Set the scope switch S 703 to "L-1".
 - (9) Observe the scope; it must show a stationary square pattern.
 - (10) Observing the scope and VTVM for stationary pattern, rotate the hundreds of cycles switch S 702 through all positions. In no position the DC VTVM must show a greater deviation than ± 5 V.

5. MID FREQUENCY LOOP, L-2

(a) Alignment

- (1) Place the test lead from J 708 (TP2) to ground.
- (2) Place the kilocycles switch S 701 in position 9.
- (3) Measure voltage with AC VTVM at J 709 (TP3) it must be 7 V.
- (4) Connect counter to J 709 (TP3).
- (5) Align following trimmers:

S 701 in Position	Trimmer	Frequency
9	C 739	18,000 \pm 6 cps
8	C 735	17,000 \pm 6 cps
7	C 733	16,000 \pm 5 cps
6	C 731	15,000 \pm 5 cps
5	C 729	14,000 \pm 5 cps
4	C 727	13,000 \pm 4 cps
3	C 725	12,000 \pm 4 cps
2	C 723	11,000 \pm 4 cps
1	C 721	10,000 \pm 4 cps
0	C 719	9,000 \pm 4 cps

(b) Phase Detector

- (1) With VTVM set for phase detector alignment, connect it to J 707 (TP1).
- (2) Remove 1 Kcs input from J 701.
- (3) Turn balance control R 712 from one extreme to the other; the DC VTVM must follow from at least -1.5 V to + 1.5 V.
- (4) Adjust R 712 for OV and lock it.
- (5) Replace 1 Kcs input to J 701.
- (6) Remove test load from TP2.
- (7) Set the scope switch to position "L-2"
- (8) Observe the scope for stationary square pattern.
- (9) In position "9", adjust L 701 for clearest square pattern obtainable.
- (10) Observing the scope and VTVM for stationary pattern, rotate the kilocycles switch S 701 through all positions. In no position the DC VTVM must show a greater deviation than \pm .5V.

6. OUTPUT FREQUENCY LOOP, L-3

(a) Alignment

- (1) Place the test lead from J 710 (TP4) to ground.
- (2) Place the "Kilocycles" switch S 701 in position 9.
- (3) Place the "Hundred of cycles" switch S 702 in position 9.
- (4) Connect 70 ohm load to J 703.
- (5) Place AC VTVM to J 703 and adjust T 702 for maximum output the voltage must be approximately 1.5 VRF.
- (6) Connect counter to J 703.
- (7) Set L 707 to its mid position.
- (8) Set L 708 to frequency 520 \pm 5 Kcs, and Lock the coil.
- (9) Re-Adjust L 707 to frequency 519900 \pm cps. and lock the coil.
- (10) Align the following trimmers.
NOTE: Leave hundreds of cycles switch in position 9; the sequenc of alignment must be followed as per chart.

S 701 in Position (Kilocycles Switch)	Trimmer	Frequency ± 10 cps
9	-----	519900 cps
8	C 780	518900 cps
7	C 779	517900 cps
6	C 778	516900 cps
5	C 777	515900 cps
4	C 776	514900 cps
3	C 775	513900 cps
2	C 774	512900 cps
1	C 773	511900 cps
0	C 772	510900 cps

(11) Rotate S 701 through all positions and recheck the frequencies.

(12) Place S 701 in position 5, and adjust following; the sequence of alignment must be followed as per chart below.

S 702 in Position Hundreds of Cycles Switch	Trimmer	Frequency ± 10 CPS
9	-----	515900 cps
8	C 790	515800 cps
7	C 789	515700 cps
6	C 788	515600 cps
5	C 787	515500 cps
4	C 786	515400 cps
3	C 785	515300 cps
2	C 784	515200 cps
1	C 783	515100 cps
0	C 782	515000 cps

(13) Rotate S 702 through all positions and recheck the frequencies.

(14) Check 510000 cps position, it must be within ± 30 cps.

(15) Check 519900 cps position, it must now be within ± 30 cps.

(16) Set in frequency output of 515500 cps and re-adjust T 702 for maximum output.

(b) Phase Detector

(1) With VTVM set for phase detector alignment, connect it to J 712 (TP6).

(2) Remove 10 Kcs input from J 705.

(3) Turn balance control R 763 from one extreme to the other; the DC VTVM must follow from at least -1.5V to + 1.5V.

(4) Adjust R 763 for 0V and lock it.

(5) Replace 10 Kcs input to J 705.

(6) Remove test lead from J 710 (TP4).

(7) Set the scope switch to "L-3".

(8) Observe the scope, it must show a stationary square pattern.

(9) Check following position, in each position scope must show stationary square pattern and the counter must read as follows.

S 701 in Position (Kilocycles Switch)	S 702 in Position (Hundreds of Cycles Switches)	Counter
0	0	510,000 ± 1 cps
0	9	510,900 ± 1 cps
6	9	516,900 ± 1 cps
6	0	516,900 ± 1 cps
9	0	519,900 ± 1 cps
9	9	519,900 ± 1 cps

Units which have passed specifications above must be prepared for alignment.
Fill out two report sheets for each unit and adjust them to your impression.

* With CHL DISCONNECTED D.C. VOLTAGES

	pin 1	pin 2	pin 3	pin 4	pin 5	pin 6	pin 7	pin 8	pin 9	pin 10	pin 11
½ V 701A (6U8)	-	- .5	90	A.C.	A.C.	90	0	-	-	XXXXX	XXXXX
½ V 701V (6U8)	160	-	-	A.C.	A.C.	-	-	2.8	.3	XXXXX	XXXXX
½ V 702A (6U8)	-	0	130	A.C.	A.C.	130	2.8	-	-	XXXXX	XXXXX
½ V 702B (6U8)	130	-	-	A.C.	A.C.	-	-	5.6	-28	XXXXX	XXXXX
½ V 703A (6U8)	-	.4	130	A.C.	A.C.	115	1.8	-	-	XXXXX	XXXXX
V 704 (6BA7)	100	-15	2.7	A.C.	A.C.	2.7	0	xxx	95	XXXXX	XXXXX
V 709 (6BA7)	90	-16	1.8	A.C.	A.C.	1.8	0	xxx	135	XXXXX	XXXXX
V 708A (6U8)	-	- .1	26	-6.3	0	130	1.8	-	-	XXXXX	XXXXX
V 708B (6U8)	130	-	-	-6.3	0	-	-	.2	-2.5	XXXXX	XXXXX
V 710 (6AU6)	.15	1.6	A.C.	A.C.	144	120	1.6	xxx	xxx	XXXXX	XXXXX
V 705 (6AU6)	- .7	0	A.C.	A.C.	136	136	0	xxx	xxx	XXXXX	XXXXX
½ V 706A (6U8)	-	-	132	A.C.	A.C.	132	2.2	-	-	XXXXX	XXXXX
½ V 706B (6U8)	132	-	-	A.C.	A.C.	-	-	.5	-4.6	XXXXX	XXXXX
V 707 (6BA7)	100	.5	2.9	A.C.	A.C.	2.9	0	xxx	100	XXXXX	XXXXX
½ V 703B (6U8)	85	-	-	A.C.	A.C.	-	-	0	- .5	XXXXX	XXXXX
V 711 (6AB4)	100	-	-	A.C.	A.C.	- .4	0	xxx	xxx	XXXXX	XXXXX
V 712A (12AT7)	220	0	3	A.C.	A.C.	-	-	-	A.C.	XXXXX	XXXXX
V 712B (12AT7)	-	-	-	A.C.	A.C.	230	- .25	2.7	A.C.	XXXXX	XXXXX
V 713 (1EP1)	A.C.	A.C.	-480	-420	-300	180	180	180	180	180	0
V 713 (1EP1)	A.C.	A.C.	-340	-320	-215	210	210	210	210	210	0

*ALL VOLTAGES MEASURED WITH RESPECT TO CHASSIS GROUND

**Scope Selector Switch Off

t-Scope Selector Switch In Position L-1

* WITH CHL CONNECTED D.C. VOLTAGES

	pin 1	pin 2	pin 3	pin 4	pin 5	pin 6	pin 7	pin 8	pin 9	pin 10	pin 11
1/2 V 701 A (6U8)	-	-6	150	A.C.	A.C.	150	0	-	-	xxxxx	xxxxx
1/2 V 701 B (6U8)	160	-	-	A.C.	A.C.	-	-	2.8	-.05	xxxxx	xxxxx
1/2 V 702 B (6U8)	134	-	-	A.C.	A.C.	134	2.8	-	-	xxxxx	xxxxx
1/2 V 703 A (6U8)	-	.4	134	A.C.	A.C.	128	1.8	-	-	xxxxx	xxxxx
V 704 (6 EA7)	106	-15	3	A.C.	A.C.	3	-1	xxx	130	xxxxx	xxxxx
V 709 (6BA7)	92	-15	1.8	A.C.	A.C.	1.8	-1	xxx	136	xxxxx	xxxxx
V 708 A (6U8)	-	-.2	25	-6.3	0	120	.4	-	-	xxxxx	xxxxx
V 708 V (6U8)	122	-	-	-6.3	0	-	-	.25	-2	xxxxx	xxxxx
V 710 (6AU6)	.25	1.6	A.C.	A.C.	146	120	1.6	xxx	xxx	xxxxx	xxxxx
V 705 (6AU6)	-16	0	A.C.	A.C.	155	153	0	xxx	xxx	xxxxx	xxxxx
1/2 V 706 A (6U8)	-	.06	134	A.C.	A.C.	134	2.3	-	-	xxxxx	xxxxx
1/2 V 706 B (6U8)	134	-	-	A.C.	A.C.	-	-	2.8	-3.8	xxxxx	xxxxx
V 707 (6BA7)	108	.9	3.1	A.C.	A.C.	3.1	-6.5	xxx	108	xxxxx	xxxxx
1/2 V 703R (6U8)	102	-	-	A.C.	A.C.	-	-	0	-1.8	xxxxx	xxxxx
V 711 (6AB4)	108	-	-	A.C.	A.C.	-3.8	0	xxx	xxx	xxxxx	xxxxx
V 712A (12AT7)	230	0	3	A.C.	A.C.	-	-	-	A.C.	xxxxx	xxxxx
V 712B (12AT7)	-	-	-	A.C.	A.C.	240	-.2	3	A.C.	xxxxx	xxxxx
V 713 (1E1)	A.C.	A.C.	-480	-425	-320	180	180	180	180	180	0
V 713 (1E1)	A.C.	A.C.	0325	-320	-220	215	215	215	215	215	0

* All Voltages Measured With Respect to Chassis Ground

** Scope Selector Switch Off

t- Scope Selector Switch In Position L-1

WITH CHL CONNECTED A.C. VOLTAGES

	pin 1	pin 2	pin 3	pin 4	pin 5	pin 6	pin 7	pin 8	pin 9	pin 10	pin 11
V 701 A (6U8)	-	4.3	0	6.3	6.3	23	0	-	-	-	-
V 701 B (6U8)	0	-	-	6.3	6.3	-	-	0	0	-	-
V 702 A (6U8)	-	.48	0	6.3	6.3	25	0	-	-	-	-
V 702 B (6U8)	0	-	-	6.3	6.3	-	-	11	15	--	-
V 703 A (6U8)	-	.8	0	6.3	6.3	18	.4	-	-	-	-
V 704 (6BA7)	0	8	0	6.3	6.3	0	3.2	xxx	1.6	-	-
V 709 (6BA7)	1	16.5	0	6.3	6.3	0	3	xxx	3.5	-	-
V 708 A (6U8)	-	.06	0	D.C.	D.C.	7.4	0	-	-	-	-
V 708 B (6U8)	0	-	-	D.C.	D.C.	-	-	1.4	3.6	-	-
V 710 (6AU6)	1.7	.04	6.3	6.3	46	0	.04	xxx	xxx	-	-
V 705 (6AU6)	11	0	6.3	6.3	10	4	0	xxx	xxx	-	-
V 706 A (6U8)	-	.4	.03	6.3	6.3	25	0	-	-	-	-
V 706 A (6U8)	0	-	-	6.3	6.3	-	-	4.4	8.3	-	-
V 707 (6BA7)	.02	4.3	.06	6.3	6.3	.06	-	xxx	23	-	-
V 703 B (6U8)	42	-	-	6.3	6.3	-	-	0	1.1	-	-
V 711 (6BA4)	9.8	-	-	6.3	6.3	2.9	0	xxx	xxx	-	-
V 712A (12AT)	15	.55	0	6.3	6.3	-	-	-	6.3	-	-
V 712 B (12AT)	-	-	-	6.3	6.3	24	.6	0	6.3	-	-
V 713 (1EP)	6.3	6.3	2	2	3	0	24	0	0	17	-

III-6-9 Test Procedure for Sideband Exciter Model CBE
(Figure III-6-7)

ALIGNMENT TEST SET UP - SECTION I

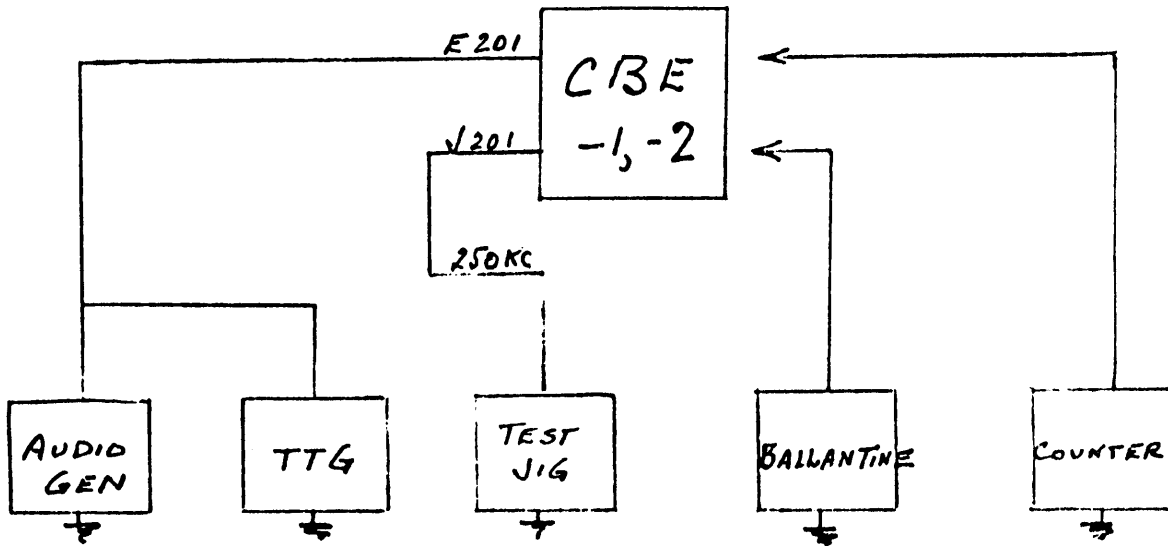

DISTORTION TEST SET UP - SECTION II

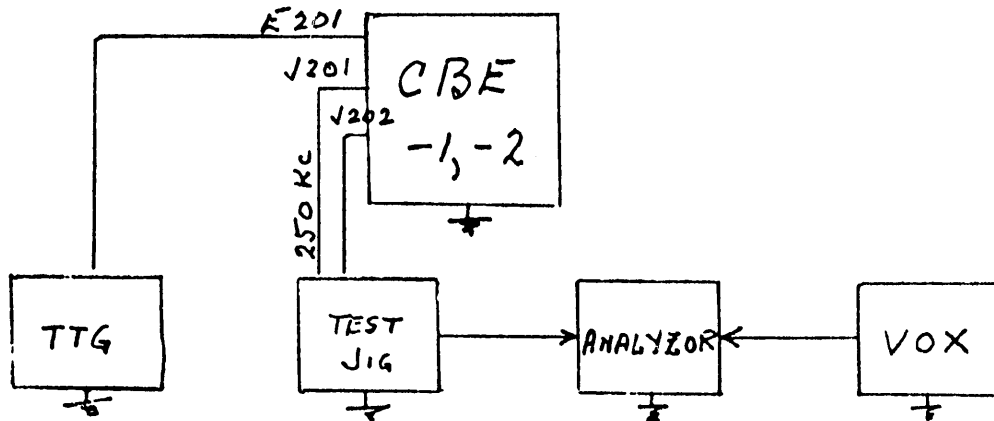

NOTE: The CBE-1 and the CBE-2 differ in one respect, the USB and LSB filter audio bandwidth. The USB and LSB filter audio bandwidth in the CBE-1 is 7.5kc; the USB and LSB filter audio bandwidth in the CBE-2 is 3.5kc

Figure III-6-7: Test Equipment Set Up for CBE.

TEST EQUIPMENT REQUIRED

1. Frequency Counter
2. A.C. VTVM (Ballantine)
3. 70 OHM Non Inductive Resistance
4. Panalyzer-Model 3B 12 A
5. Variable Frequency Oscillator (Model VOX)
6. Audio Generator
7. T.T.G.
8. Test Jig.

SECTION 1

1. PRELIMINARY

- (a) Inspect the unit for mechanical imperfections and for proper placement of filters.
- (b) Inspect for obvious wiring errors.
- (c) Check for B+ shorts with ohm meter.
- (d) Connect a 70 ohm non inductive load to J 202.
- (e) Turn both channels to OFF.
- (f) Carrier insert to OFF (CCW).
- (g) Turn AC power ON.

2. TESTING OF CBE-1 & 2

Alignment of Channel 1 and LSB.

- (a) Feed 1 to 1.45 volts at a frequency of 250 Kc to J 201. (crystal controlled).
- (b) Set the TTG for a single tone.
- (c) Connect the 70 ohm load to J 202.
- (d) With an output of .015 volts, apply TTG's voltage into channel 1 at E 201 terminals 2 and 4.
- (e) Put LSB selector switch to Channel 1. Put USB to OFF.
- (f) Check that there is .05 volts at the grid of 1st Audio Amplifier V 203, pin 6.
- (g) Place the probe of the Ballantine on the plate of the R.F. V 204 pin 1 amplifier.
- (h) Alignment of T 203. Adjust bottom slug for a maximum indication on the Ballantine, repeat the same procedure for the top slug. There should be at this point 1.4 volts.
- (i) Turn off both audio channels, make sure that the carrier reinsertion switch is OFF.
- (j) With the meter still on pin 1 of V 204 R.F. amplifier adjust R 213 and C 216 alternately to obtain minimum leakage voltage. The leak-age must not exceed 10 mv.
- (k) Lock balance potentiometer and capacitor.

Alignment of Channel 2 and USB

- (l) With the output of the TTg set at .015 volts, apply this voltage to channel 2 of E 201 terminals 6 and 8.
- (m) Check that there is .05 volts at the grid of the first Audio Amplifier V 203 pin 6.
- (o) Place the probe of the Ballantine on the plate of the R.F. amplifier V 208 pin 1.
- (n) Put USB selector Switch to channel 2.LSB to OFF.
- (p) Alignment of T 206. Adjust bottom slug for a maximum indication on the Ballantine; repeat the same procedure for the top slug. There should be at this point 1.4 volts approximately.

- (q) Turn OFF both audio channels; make sure that the carrier reinsertion switch is OFF.
- (r) With the meter still on pin 1 of V 208, R F. amplifier, adjust R 244 and C 233 alternately to obtain minimum leakage voltage. The leakage must not exceed 10 mv.
- (s) Lock balance potentiometer and capacitor.

3. CHECK FOR BANDWIDTH

- (a) Connect an audio oscillator across a 600 ohm resistor to terminals 2 and 4 of E 201.
- (b) Set the oscillator to have an output of .05 volts at 1K_c.
- (c) Set the USB selector switch to OFF.
- (d) Set the LSB selector switch to channel 1.
- (e) Connect the probe of the Ballantine, meter to output of filter Z 201.
- (f) Connect counter to the output of filter (same point as previous step).
- (g) Vary the audio generator between 250-7500 cycles for the CBE-1, or 250-3500 for the CBE-2 to obtain the peak reading on the meter. Adjust the meter to any convenient reference point. This will appear at approximately 2000 cycles for both units, CBE-1 and CBE-2.
- (h) Vary the audio generator towards the lower frequency side, 250 cycles for the CBE-1 or 250 cycles for the CBE-2. Note and record the frequency when the meter indicates a reduction of 1 db, 2 db, and 3 db. Now tune the generator towards 7500 cps. Note and record the second frequency at the 1 db, 2 db, and 3 db points. While tuning the generator to 7500 cycles from 250 cycles for the CBE-1, 3500 from 250 cycles for the CBE2, watch the meter for any variation greater than 3 db below the point which has been set as a reference point.
- (i) Subtract the two frequencies at the 3 db points. This should be less than 7150 cycles for the CBE-1 and 3250 cycles for the CBE-2.
- (j) Set the LSB selector switch to OFF.
- (k) Set the USB selector switch to channel 1.
- (l) Connect the probe of the Ballantine meter to the output of the USB filter Z203.
- (m) Connect counter to the output of filter (same point as previous step).
- (n) Vary the audio generator between 350-7500 cycles for the CBE-1, or 250-3500 for the SBE-2 to obtain the peak reading on the meter. Adjust the meter to any convenient reference point. This will appear at approximately 2000 cycles for both units, CBE-1 and 2.
- (o) Vary the audio generator towards the lower frequency side, 350 cycles for the SBE-1 or 250 cycles for the SBE-2. Note and record the frequency when the meter indicates a reduction of 1 db, 2 db and 3 db. Now tune the generator towards 7500 cps. Note and record the second frequency at the 1 db, 2 db and 3 db points. While tuning the generator to 7500 cycles from 350 cycles for the SBE-1, 3500 cycles from 250 cycles for the SBE-2, watch the meter for any variation greater than 3 db below the point which has been set as a reference point.
- (p) Subtract the two frequencies at the 3 db points. This should be less than 7150 cycles for the CBE-1 and 3250 cycles for the CBE-2.

4. ADJUSTMENT OF METERS

- (a) Feed a frequency of 1 Kc @ .015 volts into channel 1 on terminal strip E201 terminals 2 and 4 (from audio oscillator).
- (b) Turn both channel selector switches to channel with both gain controls turned fully clockwise.
- (c) Adjust R215 and R247 for FULL scale deflection on the meter. Lock potentiometers.

SECTION II

5. DISTORTION TEST

After having aligned the unit per section I, section II may be completed.

- (a) Connect the equipment as shown in figure 2.
- (b) Turn "Carrier insert" switch to OFF.
- (c) Turn LSB to OFF.
- (d) Turn USB to Channel 2 or whichever channel the audio is feeding into.
- (e) Place gain control for USB fully clockwise.
- (f) The meter should now read 100%. If not, adjust the meter and potentiometer for 100% reading.
- (g) Turn LSB to the appropriate channel, also adjust meter remembering to put gain control fully clockwise.
- (h) The following voltages should appear at the following points in order to measure distortion correctly.
 - (1) Input to CBE-1 from TTG---.015 volts.
 - (2) Output of the SBE-1 to Test jig---.05 volts.
 - (3) Output 250 Kc from Test jig to CBE-1---1.3 volts.
- (i) Set up Panalyzer for measuring distortion as follows:
 - Gain---Fully clockwise
 - Amplitude Scale switch to LOG
 - Cal. OSC level-OFF.
 - Input Attenuation-20db
 - Sweep width Selector-10Kc.
 - AFC---OFF
 - The VOX should be set at about 3470 Kc.
 - The output should be set approximately .2 ma.
 - TTG audio selector switch is set for 1 tone only.
- (j) Using the "Input Attenuator" switches on the Analyzer adjust the amplitude on the screen as close as possible to the zero (0) line, then line adjust it with the gain control.
- (k) Having completed the previous step, now locate the carrier by switching on the "carrier insert" switch on the CBE-1. Now turn the carrier OFF.
 - (l) The carrier must be at least 55 db.
 - (m) If anything else appears on the sidebands, this must be down at least 60 db.
 - (n) If any trouble has been encountered, refer back to section I.

III-6-10. Test Procedure for Frequency Amplifier (High Frequency Loop) Model CHG-1 (Figure III-6-8).

1. Set Up For Oven Test.

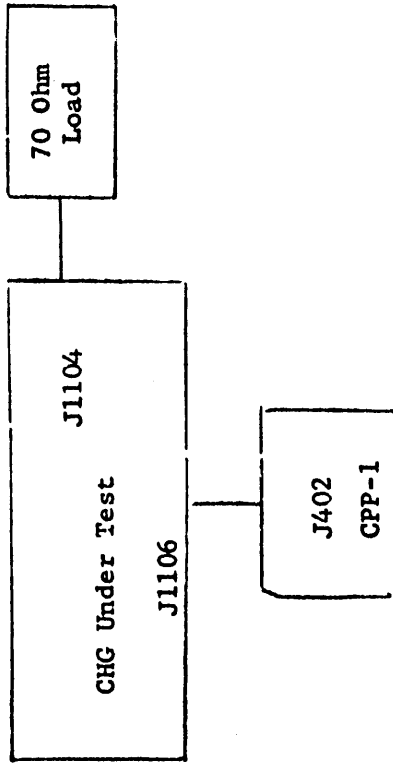

2. Set up for 1 Mc. Standard Test.

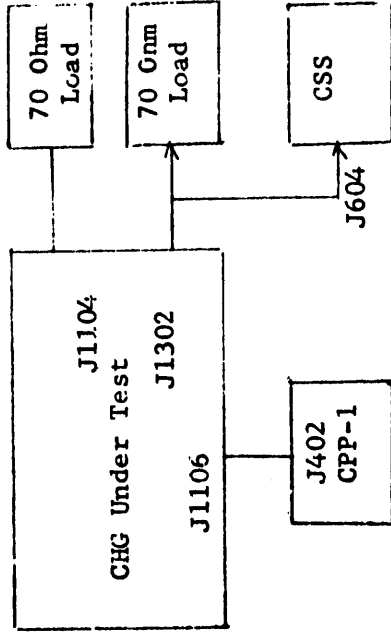

3. Set Up for Distortion Test.

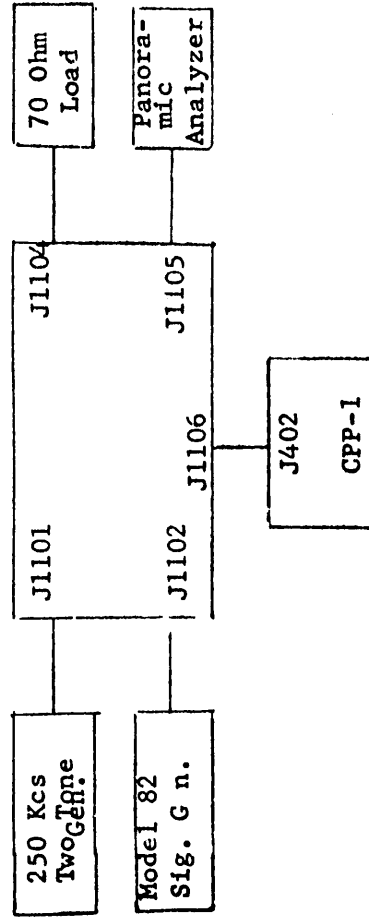

4. Test Equipment Required.

1. Simpson Multimeter Model 260.
2. Hewlett-Packard VTVM Model HP410B.
3. Two (2) each signal generators; Measurements Model B2 or equivalent.
4. Oscilloscope, Tektronix Type 545A or equivalent.
5. Electronic Counter, H.P. 524C.
6. Two-Tone 250 Kcs Generator.
7. Panoramic-Analyzoz.

Figure III - 6 - 8. Test Equipment Set Up for CHG.

1. Oven.
 - (a) Connect units to CPP-1 as shown in paragraph 1, instrument layout.
 - (b) Throw power switch in "ON" position.
 - (c) Leave B+ switch in "OFF" position.
 - (d) Observe the "oven" pilot light; it must light.
 - (e) Allow the unit to warm-up for approximately two (2) hours.
 - (f) After the oven begins to cycle, observe the time "ON" and time "OFF" periods; time "ON" approximately ten (10) minutes and time "OFF" approximately three (3) minutes at room temperature.

2. 1 MC Internal Standard.
 - (a) Set Standard Selector Switch, S1301, to "1 MC Internal."
 - (b) Connect H.P. VTVM to terminal J1502 on synthesizer chassis.
 - (c) Adjust J1305 for maximum voltage output. The voltage must be 15 V or greater.
 - (d) Connect 70 ohm load to J1302.
 - (e) Connect H.P. VTVM to the 70 ohm load.
 - (f) Adjust L1301 for maximum output on the voltmeter. The voltage must be 2.5 or greater.
 - (g) Connect CHG's 1-MC internal output at J1302 to CSS's primary standard input J604.
 - (h) Adjust CHG's C1306 (part of 1-MC internal oscillator V1302A) until the needle on CSS's meter M601 remains stationary in mid-position.

3. Synthesizer Chassis.
 - (a) Connect Scope to J1503.
 - (b) Tune T1501 for maximum 2 mc. signal. It must be approximately 35 V peak to peak.
 - (c) Disconnect P1507 from J1307.
 - (d) Disconnect P1509 from J1303.
 - (e) Disconnect P1501 from J1501.
 - (f) Connect signal generator set @ 2,000 000 cps \pm 200 cps and approximately 0.1 volts to pin 2 of V1503.
 - (g) Connect scope to the junction of R1517 and R1518.
 - (h) Tune L1503 for maximum signal at the scope, and lock the coil.
 - (i) Connect P1501 to J1501.
 - (j) Connect P1507 to J1307.
 - (k) Disconnect signal generator.
 - (l) Set Band Switch S1101 to position "2" on dial (3.75 to 5.75 mc)
 - (m) Tune C1501 for maximum signal at the scope approximately 1.5 V (PEP).
 - (n) Set Band Switch S1101 to position "4" on dial (5.75 to 7.75 Mc).
 - (o) Tune C1503 for maximum signal at the scope.
 - (p) Set Band Switch S1101 to position "6" on dial (7.75 to 9.75 Mc).
 - (q) Tune C1505 for S1101 maximum signal at the the scope.
 - (r) Set Band Switch S1101 to position "8" on dial (9.75 to 11.75 Mc).
 - (s) Tune C1512 for S1101 maximum signal at the scope.
 - (t) Set Band Switch S1101 to position "14" on dial (15.75 to 17.75 Mc).
 - (u) Tune C1507 for S1101 maximum signal at the scope.
 - (v) Set Band Switch S1101 to position "16" on dial (17.75 to 19.75 Mc).
 - (w) Tune C1515 for S1101 maximum signal at the scope.
 - (x) Set Band Switch S1101 to position "18" on dial (19.75 to 21.75 Mc).
 - (y) Tune C1513 for S1101 maximum signal at the scope.
 - (z) Set Band Switch S1101 to position "30" on dial (31.75 to 33.75 Mc).
 - (aa) Tune C1510 for maximum signal at the scope.
 - (ba) Reconnect P1509 to J1303.
 - (bb) Disconnect P1504 from J1304.
 - (bc) Measure DC Voltage at junction of R1524 and R1525. (See phase detector T1501). It must be approximately 4 volts.

- (bd) Connect the scope to junction of R1517 and R1518.
- (be) Set Balance Adjust for exact voltage measured in step 30 above, and lock it.
- (bf) Reconnect P1504 to J1304.
- (bg) Disconnect all equipment from synthesizer chassis.

4. HF Injection Oscillator

- (a) Set Scope on DC range and on .2 v per cm. vertical deflection scale.
- (b) Connect scope to junction of R1524 and R1525 and adjust the vertical position control until the horizontal line appears exactly in the center of the screen.
- (c) Without touching the scope controls, place the scope probe to the junction of R1518 and C1533. *
- (d) Tune crystals as per following chart** to the same horizontal reference line which was established in step (b) above. NOTE: When audio oscillation appears, tune toward maximum amplitude until oscillation disappears and continue turning the trimmer until the line appears in the center.

* NOTE: The voltage at the junction of R1524/R1525 should be considered as the reference d-c voltage; the voltage at the junction of R1518/C1533 must be precisely equal to the reference d-c voltage in order that the synthesizer performs most efficiently. Note that a d-c feedback voltage path exists between the junction of R1518/C1533 and the varicapacitor semiconductor C1319. The frequency output of V1303 is controlled by crystals, trimmer capacitors, and the varicapacitor semiconductor feedback circuit. Optimum results occur when the trimmers are aligned so that the voltage at the junction of R1518/C1533 corresponds precisely with the reference voltage at the junction of R1524/R1525. Under this condition, the synthesizer has maximum stability.

** BAND SWITCH POSITION	ADJUST
2	C1408
4	C1410
6	C1412
8	C1419
14	C1414
16	C1422
18	C1420
30	C1417

- (e) Check following band positions; the horizontal line must still be in the center within ± 0.25 volts.

BAND SWITCH POSITIONS ON DIAL:

0
10
12
20
22
24
26
28

- (f) Disconnect the scope.
5. Sync Circuit Indicator (V1504).
- Set Band Switch S1101 to "2" on dial.
 - Set potentiometer R1522 fully clockwise, and adjust C1536 to the point where the sync light goes off. Then advance the potentiometer R1522, to the point where the light just goes on.
 - Set the Band Switch S1101 in between positions "2" and "4"; the light must go off.
 - Check all positions "2" through "30" in all positions the light must go on.
6. Alignment of V.F. Amplifier.
- Connect scope to junction of C1122 and C1123.
 - Set Trimmer C1123 to mid-capacity.
 - Follow the chart below. In each case, the output voltage must be approximately 3 V peak to peak.

<u>BAND SWITCH.</u>	<u>TUNE FOR MAXIMUM AND LOCK THE COILS.</u>
2	L1122
4	L1121
6	L1120
8	L1119
10	L1118
12	L1117
14	L1116
16	L1115
18	L1114
20	L1108
22	L1109
24	L1110
26	L1111
28	L1112
30	L1113

7. Mid-Frequency Channel.
- Connect the 250 mcs test unit to J1101 and set it for maximum output.
 - Connect signal generator to J1102 and set it @ 1 volt and 2 mcs.
 - Set midfrequency tuning knot, to 1.75 mc. mark.
 - Set trimmers C1106, C1108, and C1114, and C1119 to mid-capacity.
 - Connect AC VTVM to pin 5 of V1102.
 - Tune T1102, L1102, and T1101 for maximum indication on the VTVM; lock T1101 only.
 - Remove VTVM.
8. R.F. CHANNEL.
- Connect signal generator to the junction of balanced modulator and R1125.
 - Set Trimmers C1132, C1133, C1134, C1143, C1144, C1145, C1191, C1152, C1153, C1154, C1155, C1165, C1166, C1167, C1168 to mid-position.
 - Observe the output meter and reduce the drive from the generator to avoid pinning the meter.
 - Turn on the B+ switch.
 - Feed approximately 0.1V. @ 1.75 mcs.
 - Set the band switch S1101 to "0" position on dial.
 - Set dial readint to 1.75 mcs.
 - Adjust T1116, T1118 and T1112 for maximum.
 - Set dial reading to 3.75 mcs.

- (j) Set generator to 3.75 Mcs.
- (k) Adjust C1168, C1155, and C1167 for maximum.
- (l) Repeat steps 5 through 11 until no further adjustments are necessary and lock coils.
- (m) Set the Band Switch S1101 to "2" position on dial.
- (n) Set generator to 3.75 mcs.
- (o) Set dial to 3.75 mcs position (Band B).
- (p) Tune T1115, T1111, T1108, T1119 for peak meter reading indication.
- (q) Set dial to 7.75 mcs position (Band B).
- (r) Tune C1167, C1154, C1145 and C1134 for peak meter reading indication.
- (s) Repeat steps 14 through 18 until no further adjustments are necessary and lock both coils.
- (t) Set Band Switch S1101 to "6" position on dial.
- (u) Set generator to 7.75 mcs.
- (v) Set dial to 7.75 mcs. (Band C).
- (w) Tune T1114, T1110, T1107 and T1117.
- (x) Set generator to 15.75 mcs.
- (y) Set dial to 15.75 mcs. (Band C).
- (z) Tune C1166, C1153, C1144, and C1133.
- (ba) Repeat steps 21 through 26 until no further adjustments are necessary. Lock the coils.
- (bb) Set generator to 15.75 mcs.
- (bc) Set Band Switch to "20" position.
- (bd) Set dial to 15.75 mcs. (Band D).
- (be) Tune T1113, T1109, T1106, and T1105.
- (bf) Set generator to 33.75 mcs.
- (bg) Set dial to 33.75 mcs. (Band D).
- (bh) Tune C1165, C1152, C1143, and C1132.
- (ci) Repeat steps 28 through 34 until no further adjustments are necessary. Lock the coil.

9. Distortion Test.

- (a) Set up equipment as shown in instrument layout.
- (b) Take distortion measurements as shown in the chart on the following page. In each case, the distortion products must be at least 40 db below each tone.

F. MC	BAND SW.	GEN. INPUT	OUTPUT TUNING DIAL BAND	A.F. TUNING DIAL WHITE FIELD (mc).	OUTPUT METER BETWEEN:
1.750	0	2	A	1.750	9-10
3.750	0	4	A	3.750	9-10
3.750	2	2	B	1.750	9-10
7.750	4	4	B	3.750	9-10
7.750	6	2	C	1.750	9-10
15.750	12	4	C	3.750	9-10
15.750	14	2	D	1.750	9-10
33.750	30	4	D	3.750	9-10.

- (C) Disconnect all equipment and prepare the unit for shipment.