



TECHNICAL MANUAL
for
RELAY PANEL ASSEMBLY
MODEL AX566



THE TECHNICAL MATERIEL CORPORATION
MAMARONECK, N. Y. OTTAWA, CANADA

COPYRIGHT 1965
THE TECHNICAL MATERIEL CORPORATION



NOTICE

THE CONTENTS AND INFORMATION CONTAINED IN THIS INSTRUCTION MANUAL IS PROPRIETARY TO THE TECHNICAL MATERIEL CORPORATION TO BE USED AS A GUIDE TO THE OPERATION AND MAINTENANCE OF THE EQUIPMENT FOR WHICH THE MANUAL IS ISSUED AND MAY NOT BE DUPLICATED EITHER IN WHOLE OR IN PART BY ANY MEANS WHATSOEVER WITHOUT THE WRITTEN CONSENT OF THE TECHNICAL MATERIEL CORPORATION.

TABLE OF CONTENTS

<u>Paragraph</u>		<u>Page</u>
	<u>SECTION 1 - GENERAL INFORMATION</u>	
1-1	Functional Description	1-1
1-2	Technical Specifications	1-1
	<u>SECTION 2 - INSTALLATION</u>	
2-1	Initial Inspection	2-1
2-2	Power Requirements	2-1
2-3	Installation	2-1
	<u>SECTION 3 - OPERATOR'S SECTION</u>	
3-1	Controls and Indicators.	3-1
	<u>SECTION 4 - PRINCIPLES OF OPERATION</u>	
4-1	Detailed Circuit Analysis.	4-1
	<u>SECTION 5 - MAINTENANCE</u>	
5-1	Preventive Maintenance	5-1
5-2	Troubleshooting	5-2
5-3	Fuse Replacement	5-2
	<u>SECTION 6 - PARTS LIST</u>	
	<u>SECTION 7 - SCHEMATIC DIAGRAMS</u>	

LIST OF ILLUSTRATIONS

Figure		Page
	<u>SECTION 1 - GENERAL INFORMATION</u>	
1-1	Relay Panel Assembly, Model AX566	1-0
	<u>SECTION 2 - INSTALLATION</u>	
2-1	AX566 Chassis Layout	2-2
	<u>SECTION 7 - SCHEMATIC DIAGRAMS</u>	
7-1	AX566, Schematic Diagram	7-1

LIST OF TABLES

Table		Page
	<u>SECTION 1 - GENERAL INFORMATION</u>	
1-1	Technical Specifications	1-1

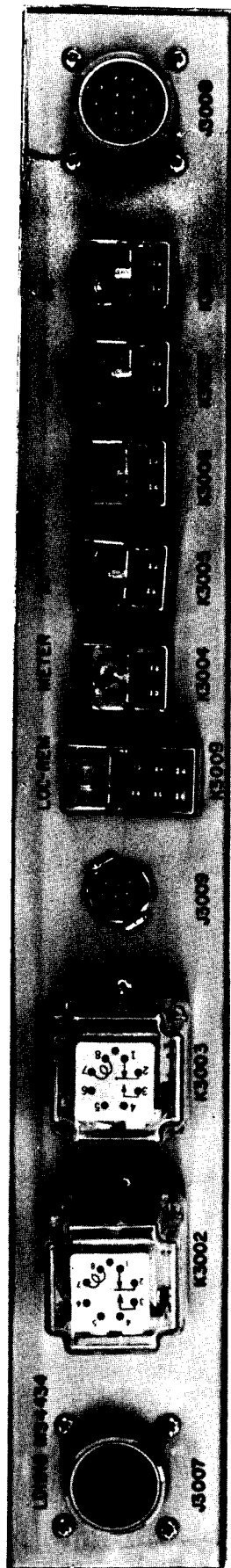

Figure 1-1. Relay Panel Assembly, Model AX566

SECTION 1
GENERAL INFORMATION

1-1. FUNCTIONAL DESCRIPTION.

Relay Panel Assembly, Model AX566 (figure 1-1), contains eight continuous-duty 24-volt d-c relays that can function to control external equipment. The relays may be operated by either local or remote signals.

1-2. TECHNICAL SPECIFICATIONS.

Table 1-1 lists the technical specifications of the AX566.

TABLE 1-1. TECHNICAL SPECIFICATIONS

Input Voltage Required:	24 volts dc.
Modes of Operation:	Local or remote.
Number of Relays:	Eight.
Types of Relays:	SPDT(2); DPDT (5); 6PDT(1).
SPDT Relays:	
DC Resistance	400 ohms.
Operating Voltage	24 volts dc.
Coil Power Re- quired (nominal)	1 to 2 watts.
Temperature Range	-55°C to +50°C.
DPDT Relays:	
DC Resistance	700 ohms <u>+10%</u> .
Operating Voltage	24 volts dc.
Operating Current	35 milliamperes.
Maximum Actuating Operating Time	Approximately 15 milliseconds.
Number of coil windings	One.

6PDT Relay:

DC Resistance	430 ohms <u>+10%</u> .
Operating Voltage	24 volts dc.
Operating Current	56 milliamperes.
Maximum Actuating Operating Time	Approximately 15 milliseconds.
Number of coil windings	One.

Dimensions: 16-1/8" wide x 2-1/4" high
x 4-1/8" deep.

Weight: Approximately 2 pounds.



SECTION 2
INSTALLATION

2-1. INITIAL INSPECTION.

The AX566 is tested at the factory prior to shipment. When it arrives at the operating site, inspect the packing case and contents for possible damage. Inspect all packing material for parts that may have been shipped as "loose items". With respect to damage to the equipment for which the carrier is liable, The Technical Materiel Corporation will assist in describing methods of repair and furnishing of replacement parts.

2-2. POWER REQUIREMENTS.

The AX566 requires 24 volts dc for operation.

2-3. INSTALLATION.

Refer to figure 2-1. The AX 566 is a U-shaped unit approximately 16-1/8" wide, 2-1/4" high, and 4-1/8" deep. To install the unit, proceed as follows:

a. Secure the unit with six 6/32 machine screws. Provide sufficient space for access to the panel-mounted connector receptacles (J3007, J3008, and J3009) illustrated in figure 1-1.

b. Refer to figure 7-1 and make the necessary electrical connections between the relay panel and the external equipment.

NOTES:

1. "A" designates mounting hole. Diameter of hole is 0.172 inches. Use $6/32$ machine screws.
2. All dimensions are in inches.

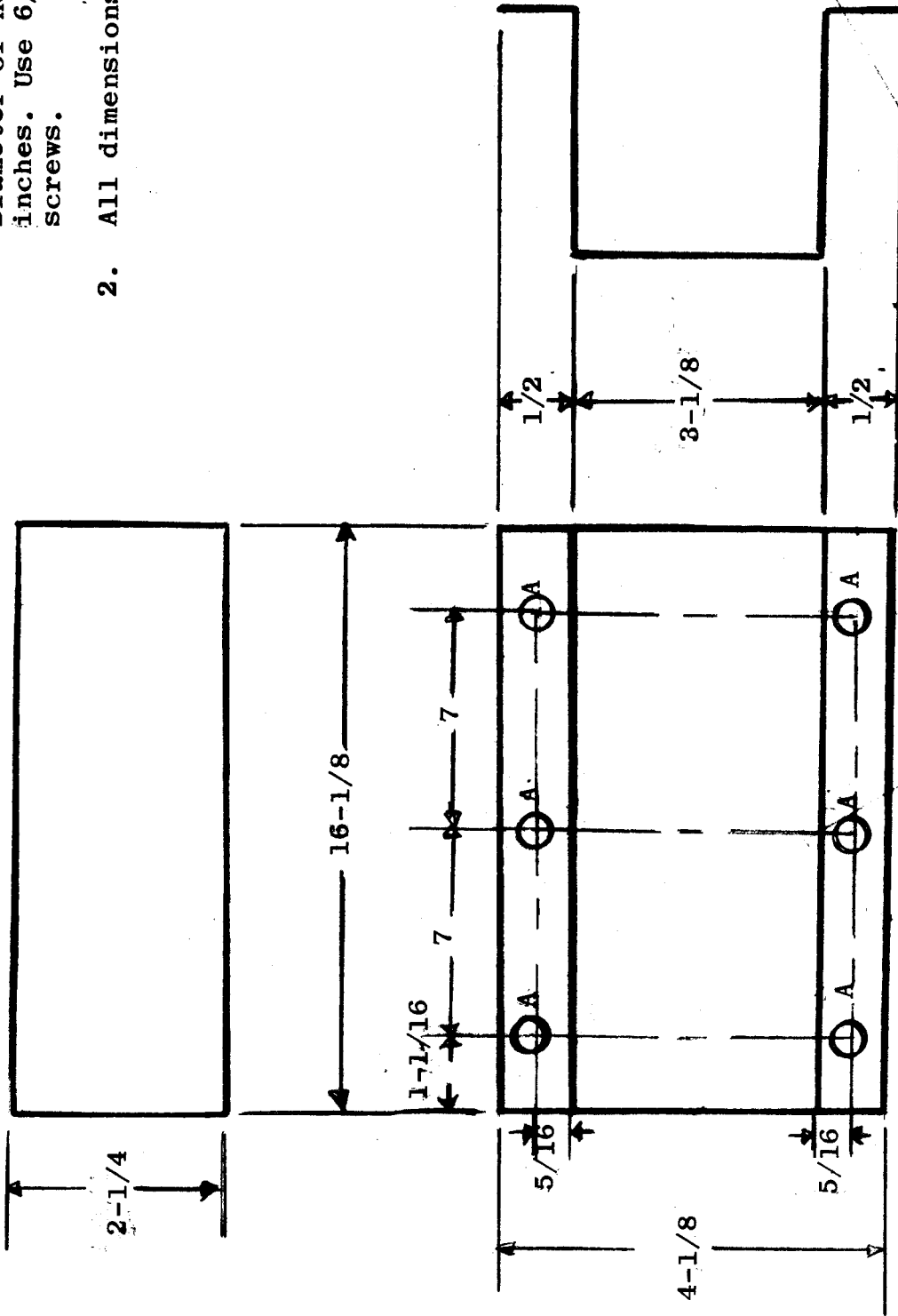

Figure 2-1. AX566 Chassis Layout

SECTION 3
OPERATOR'S SECTION

3-1. CONTROLS AND INDICATORS.

There are no operating controls; therefore, there are no operating procedures.

SECTION 4
PRINCIPLES OF OPERATION

4-1. DETAILED CIRCUIT ANALYSIS.

Refer to figure 7-1. The AX566 relays can be operated locally or from a remote location. An external ground signal applied to pin "C" of J3007 determines the mode of operation.

In the local mode of operation, the external 24 volts dc and ground signals appearing at J3009 pins "A" and "C", respectively, are applied across the coil terminals of relay K3009. With relay K3009 energized, the 24 volts is applied via relay controls 21 and 22 to one of the coil terminals of relays K3002 through K3008. In addition, internal ground signals provided at the other relay controls of K3009 are applied to the second coil terminal of relay K3002 and relays K3005 through K3008. This energizes all of the relays with the exception of K3003 and K3004. When relay K3002 is energized, pins "L" and "M" of J3007 are short circuited. When relays K3005 through K3008 are energized, the short circuits placed across pins "A" and "B", "C and "D", "E and "F", "H and "J" by the contacts of the associated relays are removed.

Remote relay operation is established by removing the external ground signal applied to pin "C" of J3009. Removing this ground signal deenergizes relay K3009. With K3009 deenergized, 24 volts dc is applied from pins "A" and "B" of J3009 to one of the coil terminals of relays K3002 through K3008. However, the ground signals applied through the contacts of relay K3009 to

the other coil terminals of the associated relays are removed. Removing the internal ground signals places all relays in the deenergized state. Therefore, an external ground signal applied to any one of pins "C" through "K" of jack 3007 will energize the associated relay. For example, a ground signal appearing at pin "C" of J3007 will be routed to a coil terminal of K3002 via contacts 2 and 3 of relay K3009. This ground signal will energize relay K3002.

With 24 volts dc applied to pins "A" and "B" of J3009, 24 volts dc is always available at pin D of J3009 in either mode of relay operation.

SECTION 5
MAINTENANCE

5-1. PREVENTIVE MAINTENANCE.

The AX566 has been designed to provide long-term, trouble-free operation under continuous duty conditions. However, in order to prevent failure of the equipment due to corrosion, dust, or other destructive elements, it is suggested that a schedule of preventive maintenance be set up and adhered to.

At periodic intervals, the equipment should be removed from its mounting for cleaning and inspection. The wiring and all components should be inspected for dirt, corrosion, charring, discoloring or grease. Remove dust with a soft brush or vacuum cleaner. Remove dirt or grease from other parts with any suitable cleaning solvent. Use of carbon tetrachloride should be avoided due to its highly toxic effects. Trichlorethylene or methyl chloroform may be used, providing the necessary precautions are observed.

NOTE

When using toxic solvents, make certain that adequate ventilation exists. Avoid prolonged or repeated breathing of the vapor. Avoid prolonged or repeated contact with skin. Flammable solvents shall not be used on energized equipment or near any equipment from which a spark may be received. Smoking, "hot work", etc. is prohibited in the immediate area.

CAUTION

When using trichlorethylene, avoid contact with painted surfaces due to its paint removing effects.

5-2. TROUBLESHOOTING.

There are no relay actuating adjustments. To determine if a relay is defective, connect 24 volts dc across the relay coil terminals. If the relay fails to energize, the relay can be considered to be defective and should be replaced. An ohmmeter check can reveal an open coil winding. The dc resistance of each relay is given below.

RELAY	DC RESISTANCE (OHMS)
K3002	400
K3003	400
K3004	700 $\pm 10\%$
K3005	700 $\pm 10\%$
K3006	700 $\pm 10\%$
K3007	700 $\pm 10\%$
K3008	700 $\pm 10\%$
K3009	430 $\pm 10\%$

5-3. FUSE REPLACEMENT.

There are no fuses in the AX566 unit.

SECTION 6

PARTS LIST

6-1. INTRODUCTION

The parts list presented in this section is a cross-reference list of parts identified by a reference designation and TMC part number. In most cases, parts appearing on schematic diagrams are assigned reference designations in accordance with MIL-STD-16. Wherever practicable, the reference designation is marked on the equipment, close to the part it identifies. In most cases, mechanical and electro-mechanical parts have TMC part numbers stamped on them.

To expedite delivery when ordering any part, specify the following:

- a. Generic name.
- b. Reference designation.
- c. TMC part number.
- d. Model and serial numbers of the equipment containing the part being replaced; this can be obtained from the equipment name-plate.

For replacement parts not covered by warranty (refer to warranty sheet in front of manual), address all purchase orders to:

The Technical Materiel Corporation
Attention: Sales Department
700 Fenimore Road
Mamaroneck, New York

PARTS LIST

for

RELAY PANEL ASSEMBLY, AX-566

REF SYMBOL	DESCRIPTION	TMC PART NUMBER
J3000 thru J3006	NOT USED	
J3007	CONNECTOR, RECEPTACLE, ELECTRICAL: 24 number 20 pin type contacts rated for 7.5 amperes, 500 V RMS nominal.	JJ200-4
J3008	CONNECTOR, RECEPTACLE, ELECTRICAL: 14 number 16 pin type contacts rated for 17.0 amperes, 500 V RMS nominal.	JJ200-4
J3009	CONNECTOR, RECEPTACLE, ELECTRICAL: 9 male pin type contacts rated for 7.5 amps, 2000 V RMS 60 cps at sea level and 700 V RMS 60 cps at 50,000 ft. altitude; miniature hexagon.	JJ193-9P
K3000	NOT USED	
K3001	NOT USED	
K3002	RELAY, GENERAL PURPOSE: 24 VDC.	RL168-1C5-24DC
K3003	Same as K3002.	
K3004	RELAY, ARMATURE: DPDT; 700 ohms, +10% DC resistance; operating voltage 24 VDC; current rating 35 ma, 700 mw at 25°C; contacts rated for 5 amps at 29 VDC; clear high impact styrene dust cover case.	RL156-1
K3005 thru K3008	Same as K3004.	
K3009	RELAY, ARMATURE: 6PDT; 45 ohms, +10% DC resistance; operating voltage 24 VDC; current rating 56 ma; 1,500 mw at 25°C; contacts rated for 5 amps at 29 VDC; clear high impact styrene dust cover case.	RL156-5
XK3000	NOT USED	
XK3001	NOT USED	
XK3002	SOCKET, ELECTRON TUBE: octal, high crown.	TS101P01

RELAY PANEL ASSEMBLY, AX-566 (CONT)

REF SYMBOL	DESCRIPTION	TMC PART NUMBER
XK3003	Same as XK3002.	
XK3004	SOCKET, RELAY: with retainer; 6 beryllium copper gold plated contacts; black pherolic socket.	TS171-1
XK3005 thru XK3008	Same as XK3004.	
XK3009	SOCKET, RELAY: with retainer; 18 beryllium copper gold plated contacts; black pherolic socket.	TS171-2



SECTION 7
SCHEMATIC DIAGRAMS

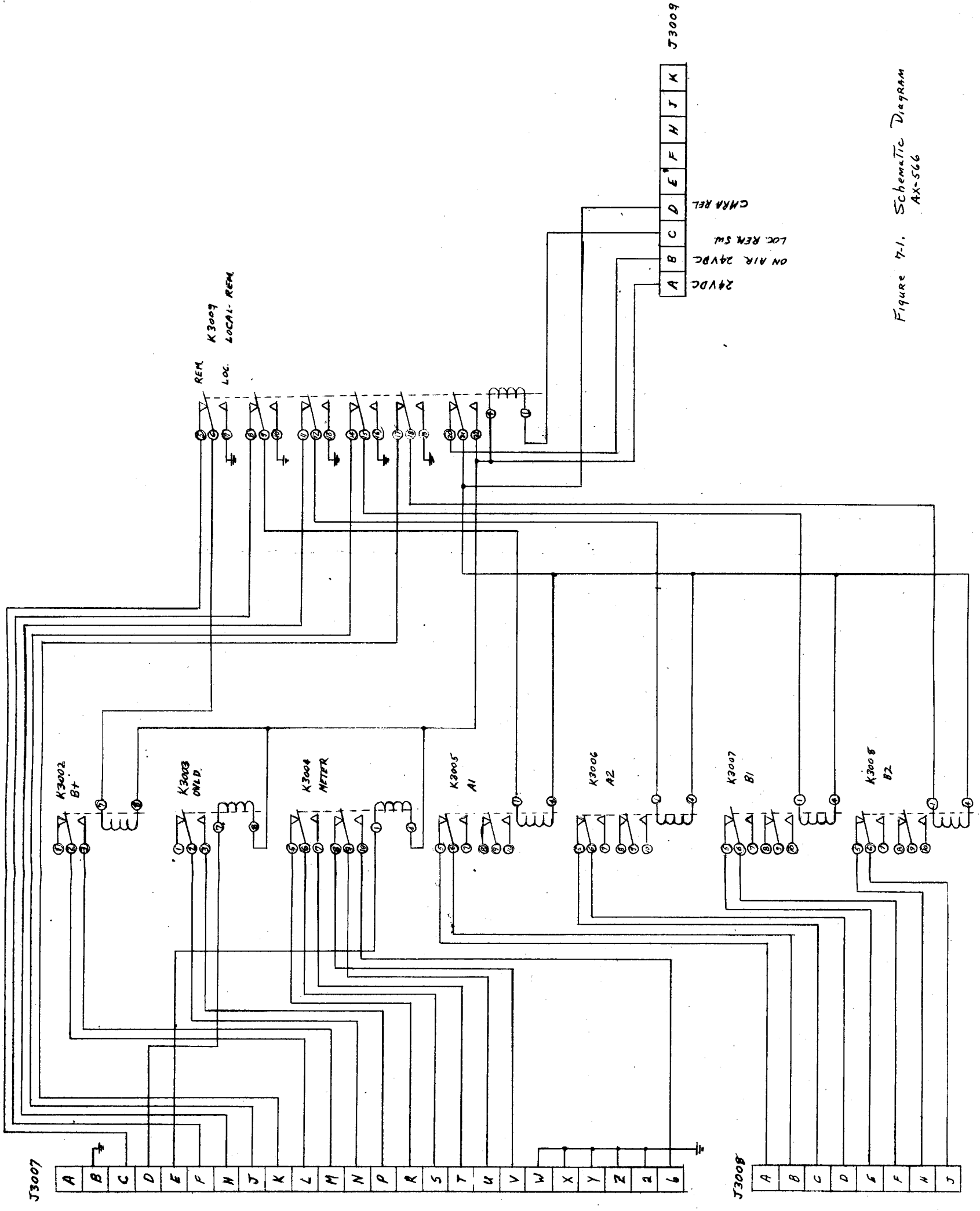

Figure 7-1. Schematic Diagram
AX-566