

REVISIONS						
ZONE	LTR	DESCRIPTION	DATE	E.M.N.NO	DRAFT	CHKD APPD
	A	COMPLETELY REVISED & REDRAWN	9-7-67	1B495	G.D.L.	<i>[Signature]</i>

**SYMBOLS USED IN MARKING PRINT**

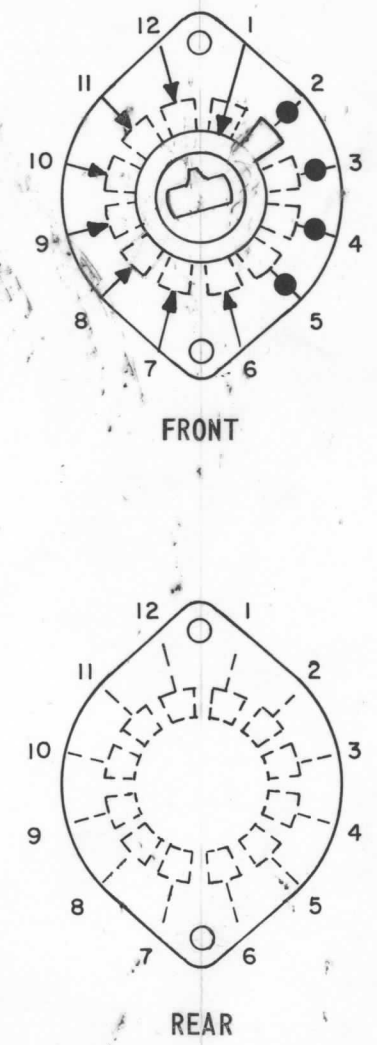
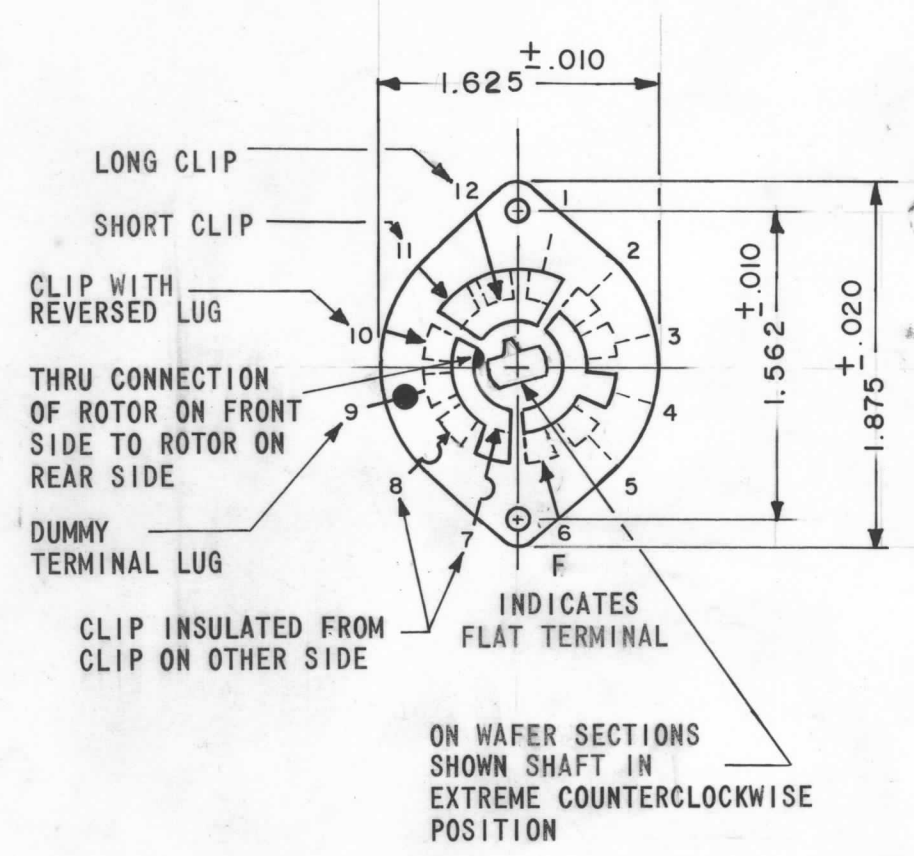

**MECHANICAL SPECIFICATIONS :**

NUMBER OF SECTIONS - \_\_\_\_\_  
 NUMBER OF POSITIONS - \_\_\_\_\_  
 ANGLE OF THROW - 30°

**CONTACTS:**

SHORTING TYPE, SECTIONS 1 (FRONT)  
 NON SHORTING TYPE, SECTIONS \_\_\_\_\_  
 SILVER PLATED BRASS, SECTIONS ✓  
 SILVER ALLOY, SECTIONS \_\_\_\_\_

**WAFERS:**

BAKELITE, SECTIONS .062 ±.005 THICK  
 CERAMIC, SECTIONS \_\_\_\_\_  
 MYCALEX, SECTIONS \_\_\_\_\_  
 IMPREGNATION (IF REQ.) \_\_\_\_\_

**FINISH REQUIREMENTS:**

ARMY ✓ NAVY ✓ COMMERCIAL \_\_\_\_\_

**ELECTRICAL SPECIFICATIONS :**

MAXIMUM RATED VOLTAGE N/A  
 MAXIMUM RATED CURRENT N/A

4	HFI - I	
QTY / UNIT	MODEL USED ON	ASS'Y NO.
APPLICATION		
	CODE	S401 - 61

**NOTICE TO PERSONS RECEIVING THIS DRAWING**  
 THE TECHNICAL MATERIEL CORPORATION claims proprietary right in the material disclosed hereon. This drawing is issued in confidence for engineering information only and may not be reproduced or used to manufacture anything shown hereon without permission from THE TECHNICAL MATERIEL CORPORATION to the user. This drawing is loaned for mutual assistance and is subject to recall at any time.

UNLESS OTHERWISE SPECIFIED DIMENSIONS ARE IN INCHES AND INCLUDE CHEMICALLY APPLIED OR PLATED FINISHES	
DECIMALS	FRACTIONS
.X ± .05	1/64
.XX ± .01	TOLS. ANGLES
.XXX ± .005	0° - 30'
MATERIAL	
FINISH	

REQ'D	ITEM	PART NUMBER	DESCRIPTION	SYM.
O. POSE				
LIST OF MATERIAL				
THE TECHNICAL MATERIEL CORP. MAMARONECK, NEW YORK				
WAFER, SWITCH ROTARY				
SIZE	CODE IDENT. NO.	DWG NO.	ISSUE	
B	82679	WS126	A	
SCALE			SHEET OF	