

TMC NUMBER	MFRS. REF	MFRS. NO.	APPROX. RADIUS	O.D.	I.D.	A	THICK	SCREW CLEARANCE	STD. MATL. FINISH
WA-131-1	A	3502-02-01		.307 - .297	.095	.041 - .021	.009	2	
WA-131-2	A	Special		.250 - .240	.115	.105 - .085	.008	3 - 4	
WA-131-3	A	3502-05-13		.370 - .360	.135	.080 - .050	.006	5	
WA-131-4	A	3502-07-07		.245 - .235	.155	.053 - .033	.010	6	
WA-131-5	A	3502-07-06		.307 - .297	.151	.061 - .041	.010	6	
WA-131-6	A	3502-08-00		.245 - .235	.168	.053 - .033	.010	8	
WA-131-7	A	3502-08-04		.370 - .360	.166	.080 - .050	.015	8	
WA-131-8	A	3502-10-55		.370 - .360	.198	.080 - .050	.010	10	
WA-131-9	A	3502-10-10		.432 - .422	.198	.080 - .050	.010	10	
WA-131-10	A	3502-10-58		.495 - .485	.198	.100 - .060	.008	10	
WA-131-11	A	3502-10-56		.495 - .485	.198	.100 - .060	.015	10	
WA-131-12	A	3502-10-31		.557 - .547	.198	.100 - .060	.008	10	
WA 131-13	A	3502-12-01		.380 - .370	.225	.083 - .063	.010	12	
WA-131-14	A	3502-14-27		.495 - .485	.260	.100 - .060	.015	1/4	
WA-131-15	A	3502-14-15		.557 - .547	.263	.130 - .100	.015	1/4	
WA-131-16	A	3502-18-00		.495 - .485	.322	.100 - .060	.013	5/16	
WA-131-17	A	3502-20-32		.630 - .620	.384	.105 - .085	.015	3/8	
WA-131-18	A	3502-22-01		.755 - .745	.435	.150 - .130	.015	7/16	
WA-131-19	A	3502-24-21		.755 - .745	.500	.140 - .120	.015	1/2	
WA-131-20	A	3502-26-00		.880 - .860	.576	.150 - .120	.010	9/16	
WA-131-21	A	3502-28-01		.755 - .745	.638	.113 - .083	.010	5/8	
WA-131-22	B	1-W	-	.225	.130	.035	.008	5	RN
WA-131-23	B	2-W	7/16	.375	.199	.050	.010	10	RN

MATERIAL	FINISH	SYMBOL
Brass	Natural	B
Brass	S-105 Cadmium Plate	BC
Steel, Spring	Oil Treated	S
Bronze	Natural	R
Beryllium Copper	Natural	C
Phosphor Bronze Spring Temper	Nickel Plated	RN

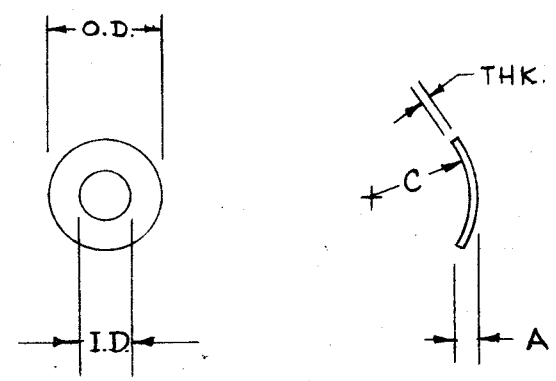

Nomenclature to be in the following form:

WA-131-3 C
 TMC TYPE & SIZE MATERIAL & FINISH

MAMARONECK

9773	AK	JWZ	WOB
CH. NO.	DRAFTS	CHECKER	ENG. APP.

ALL ALLOWABLE TOLERANCES HAVE DETERMINED AND ANY DEVIATIONS CAUSE FOR REJECTION.
 ALL BURRS AND SHARP EDGES

REQ. PER UNIT	MODEL	PROJECT NO.	ASSY. NO.	DATE
USED ON				

Ref: A-8401-234
 B-8401-214

REQ. ITEM	PART NO.	DESCRIPTION	SYMBOL
		THE TECHNICAL MATERIEL CORP. MAMARONECK, NEW YORK	
STOCK SIZE		WASHER, SPRING TENSION	H61
MATERIAL			
TYPE & TEMPER	HEAT TREAT. SPEC.	DRAWN	CHECKED
FINISH & SPEC. NO.		ELEC. DES. APP.	MECH. DES. APP.

16 3/28/58
 WA-131 A