

IF IT IS FOUND DESIRABLE TO CHANGE ANY TOLERANCE OR OTHER DETAIL SPECIFIED ON THIS DRAWING NOTIFY THE PURCHASER PROMPTLY.

# STANDARD DRAWING

UG-296/U | A

MAXIMUM ALLOWABLE TOLERANCES HAVE BEEN DETERMINED AND DEVIATIONS WILL BE CAUSE FOR REJECTION. REMOVE ALL BURRS AND SHARP EDGES

USED ON

MODEL	PROJECT NO.	ASS'Y. NO.	DATE
TAC-1	132	A-579	12/27/53

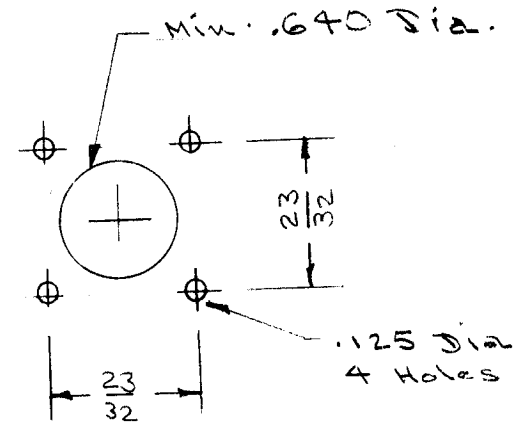
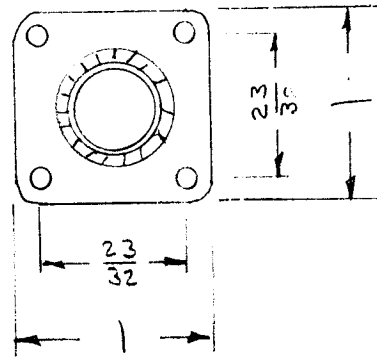
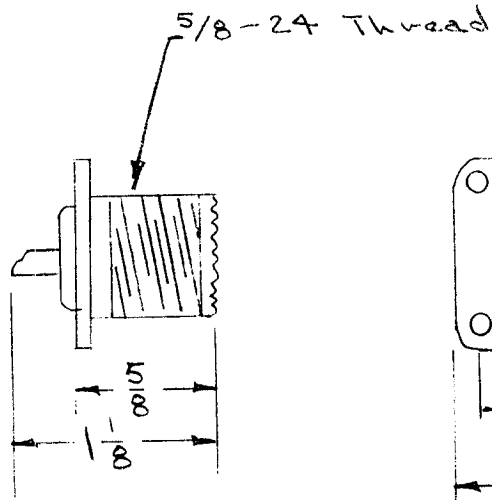

DRILLING PLAN.

DIMENSIONS FOR REF ONLY

NOTE:

SO-239A TO BE USED IN PLACE OF UG-296/U

INSULATION: TEFLON

REQ.	ITEM	PART NO.	DESCRIPTION	SYMBOL
			THE TECHNICAL MATERIEL CORP.	
			MAMARONECK. NEW YORK	
STOCK SIZE			RECEPTACLE	
MATERIAL		WEIGHT PER PC.		
TYPE & TEMPER			G.T.O	
DRAWN			ELEC. DES. APP.	MECH. DES. APP.
HEAT TREAT. SPEC.			CHECKED	FINAL APPROVAL
FINISH & SPEC. NO.			UG-296/U   A	

A	I	NOTE ADDED	DATE	CN. NO.	DRAFTS	CHECKER	ENG. APP.
		NOTE ADDED	12/14/56	1	JAD	WIC	ARB
ISSUE ITEM		CHANGED FROM	DATE	CN. NO.	DRAFTS	CHECKER	ENG. APP.
TOLERANCES			SCALE				
ALL OTHERS	DEC. DIM. ± FRAC. DIM. ± ANGULAR DIM. ±		DRILL, PUNCH, COMMERCIAL STOCK SIZES AND MANUFACTURERS TOLERANCES ARE NOT INCLUDED.				