

THE CONTENTS OF THIS DRAWING ARE THE EXCLUSIVE PROPERTY OF THE TECHNICAL MATERIEL CORP. ITS UNAUTHORIZED USE FOR REPRODUCTION IN WHOLE OR IN PART IS STRICTLY FORBIDDEN.

REQ. PER UNIT

1

USED ON

MODEL

TTR-10

ASS'Y. NO.

AX-410

DATE

5-21-63

TZ-118

A

SYMBOL	FUNCTION	OPER. FREQ.	USED ON	QUAN.
T1201	IFT Tank	4 to 8 mc.	AX-410	1

SPECIFICATIONS

WINDING DATA: INDUCTANCE: 3.65 ± .10 uhy (Blk-BLU)
.91 ± .05 uhy (BLK-GRN)

Total Turns - 28
Turns At Tap - 10

COIL FORM: Powdered Iron

LEADS: Size 28 Wire, 1-1/2 Long

COLOR CODE

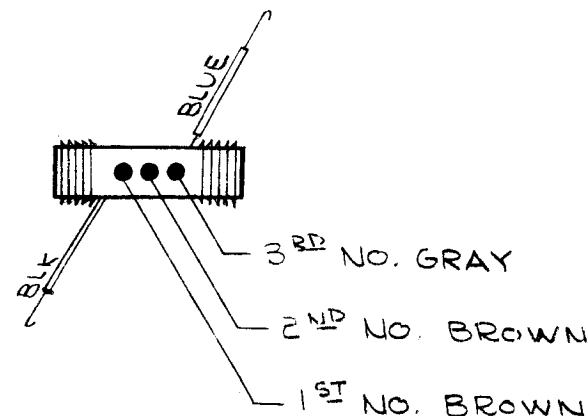
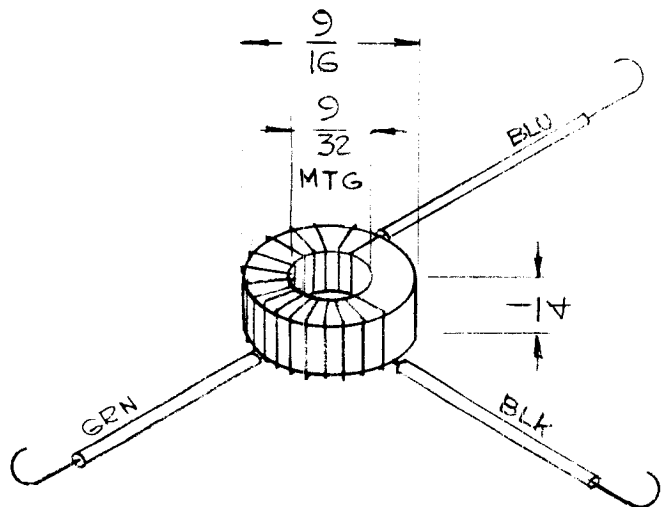

NOTE:
COLORS DENOTE
"TZ" NUMBER IN
RETMA COLOR CODE.

REQ.	ITEM	PART NO.	KOHN	DESCRIPTION	E 3037-77	SYMBOL
				THE TECHNICAL MATERIEL CORP. MAMARONECK. NEW YORK		
				TRANSFORMER, R.F., IFT		
				4 - 8 MC.		
A	CLERICAL CHANGE	8.24.64	HB	@		
SYM	DESCRIPTION	DATE	CH. NO.	DRAFTS	CHECKER	ENG. APP.
UNLESS OTHERWISE SPECIFIED DIMENSIONS ARE IN INCHES AND INCLUDE CHEMICALLY APPLIED OR PLATED FINISHES		SCALE	NONE			
DECIMALS .X ± .05 .XX ± .01 .XXX ± .005	TOLERANCES	FRACTIONS ± 1/64 ANGLES ± 0° 30'	CODE	2A-3156		
					G.D.L.	FILE 5/24/63
					DRAWN	CHECKED
					RON KOHN	BP
					ELEC. DES. APP.	MECH. DES. APP.
						TZ-118
						A