

SYMBOL	FUNCTION	OPER FREQ	REQ. PER UNIT	USED ON		
				MODEL	ASS'Y. NO.	DATE
T5	IF FILTER TRANSF	455 KC	1	GPR-91RXD		9-16-63

TT-192

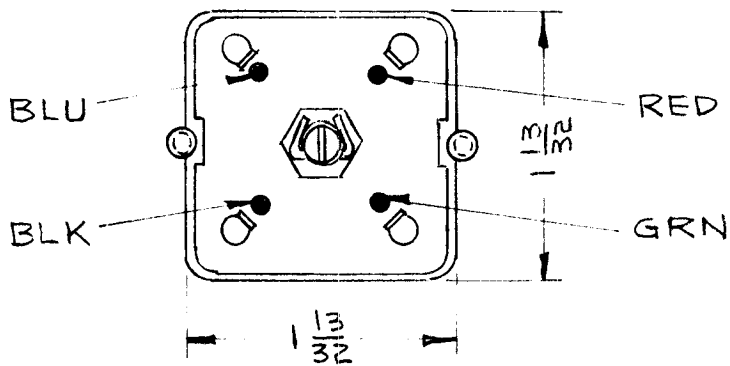
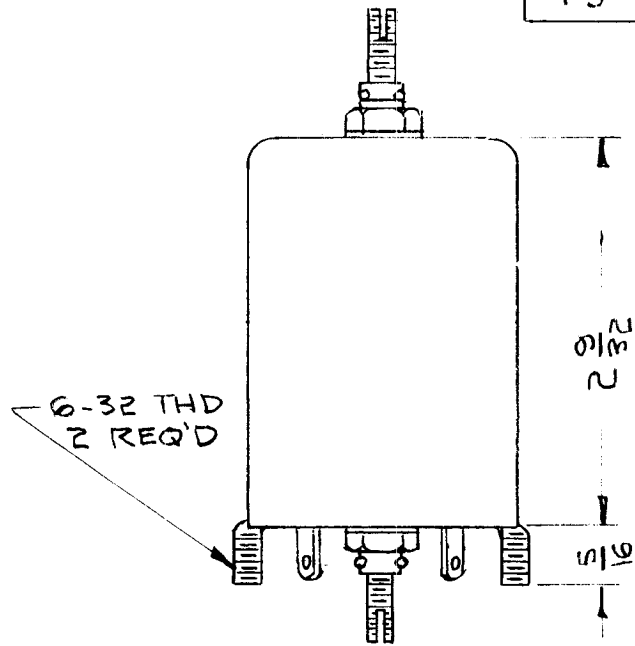

**WINDING DATA**  
**WINDING NO. 1**  
 NOMINAL INDUCTANCE = 415UH  
 NO. OF TURNS = 190T

**WINDING NO. 2**  
 NOMINAL INDUCTANCE = 40UH  
 NO. OF TURNS = 60T  
 NO. OF TAPS = 1  
 NO. OF TURNS TAPPED = TAPPED AT 30T

**COIL FORM DATA**  
 MATERIAL = PHENOLIC

**TUNING DEVICES**  
 TYPE = CORE, TUNING

**CASE DATA**  
 MATERIAL = ALUMINUM

**TERMINALS**  
 TYPE = LUG, 4 REQ'D

SCHMATIC DIAGRAM

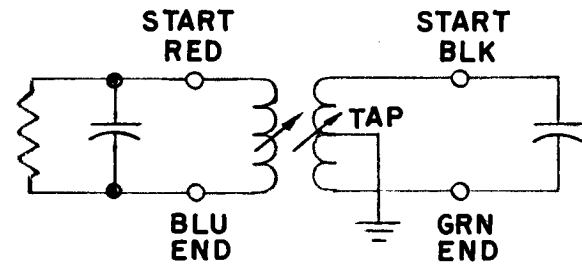

REQ. ITEM	PART NO.	DESCRIPTION	SYMBOL
		R. HAY	
STOCK SIZE		THE TECHNICAL MATERIEL CORP. MAMARONECK, NEW YORK	
MATERIAL		TRANSFORMER, IF TUNED	
TYPE & TEMPER		7/14/63	BF
HEAT TREAT. SPEC.		DRAWN	CHECKED
FINISH & SPEC. NO.		ELEC. DES. APP.	MECH. DES. APP.
UNLESS OTHERWISE SPECIFIED DIMENSIONS ARE IN INCHES AND INCLUDE CHEMICALLY APPLIED OR PLATED FINISHES		SCALE NONE	
TOLERANCES		CODE 2A-3252	
DECIMALS .X ± .05 .XX ± .01 .XXX ± .005		FRACTIONS ± 1/64 ANGLES ± 0° 30'	
		TT-192	