

FUNCTION	OPER. FREQ	SYMBOL	REQ. PER. UNIT	USED ON		
				MODEL	ASSY. NO.	DATE
OSC. COIL BAND 3	3.755 - 6.055 MC	T120	1	GPR-92		9-12-61

TT-143

SPECIFICATIONS

- Q- L1 100 OR GREATER
- L2 -85 OR GREATER
- Luh- L1 8.2 (7.8 - 8.6)
- L2-5.5 (5.25 - 5.78)
- F- L1-7.9MC
- L2-7.9MC

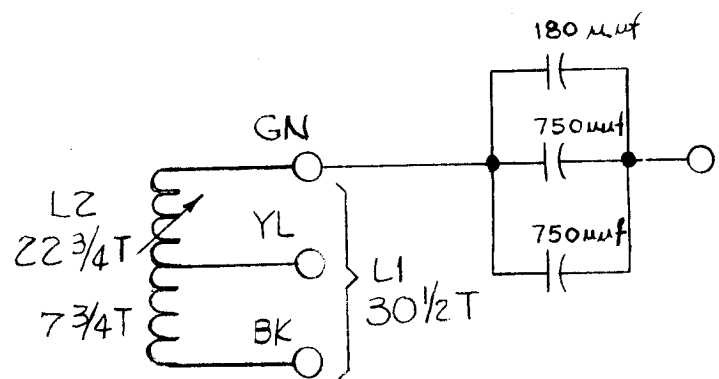
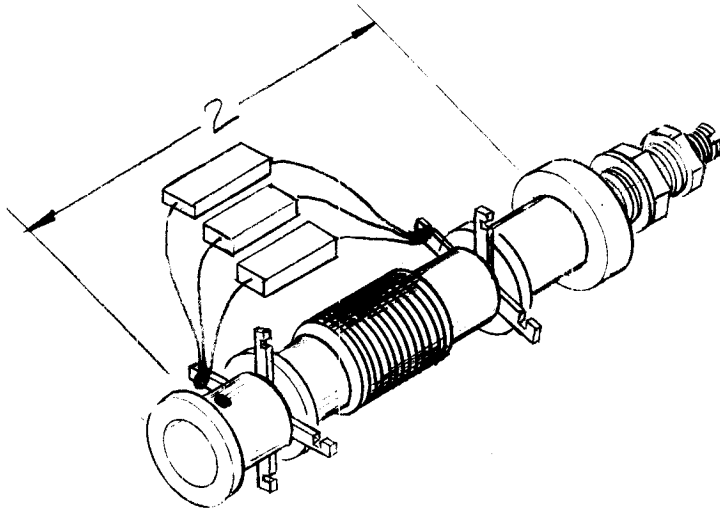

FREQ. RANGE 3.755 to 6.055 MC

— SCHEMATIC —

								REQ.	ITEM	PART NO.	GELLMAN	DESCRIPTION	SYMBOL				
												THE TECHNICAL MATERIEL CORP.					
												MAMARONECK, NEW YORK					
												TRANSFORMER, RF TUNED					
ISSUE	ITEM	CHANGED FROM	DATE	CH. NO.	DRAFTS	CHECKER	ENG. APP.				RUZZO	TR 9/23/61	RAL				
TOLERANCES			SCALE: 2A-2126														
DEC. DIM. ±			MAXIMUM ALLOWABLE TOLERANCES HAVE BEEN DETERMINED AND ANY DEVIATIONS WILL BE CAUSE FOR REJECTION. REMOVE ALL BURRS AND SHARP EDGES					TYPE & TEMPER	HEAT TREAT. SPEC.			DRAWN	CHECKED	FINAL APPROVAL			
FRAC. DIM. ±																	
ANGULAR DIM. ±																	
								FINISH & SPEC. NO.				ELEC. DES. APP	MECH. DES. APP	TT-143			