

REVISIONS							
ZONE	LTR	DESCRIPTION	DATE	E.M.N.NO	DRAFT	CHKD	APPD
	X	EXP. RELEASE					
	<del>0</del>	ORIGINAL RELEASE FOR PRODUCTION	4/1/75				
	A	ITEM 9 ADD	7-11-75	21238	G. De Lucia		

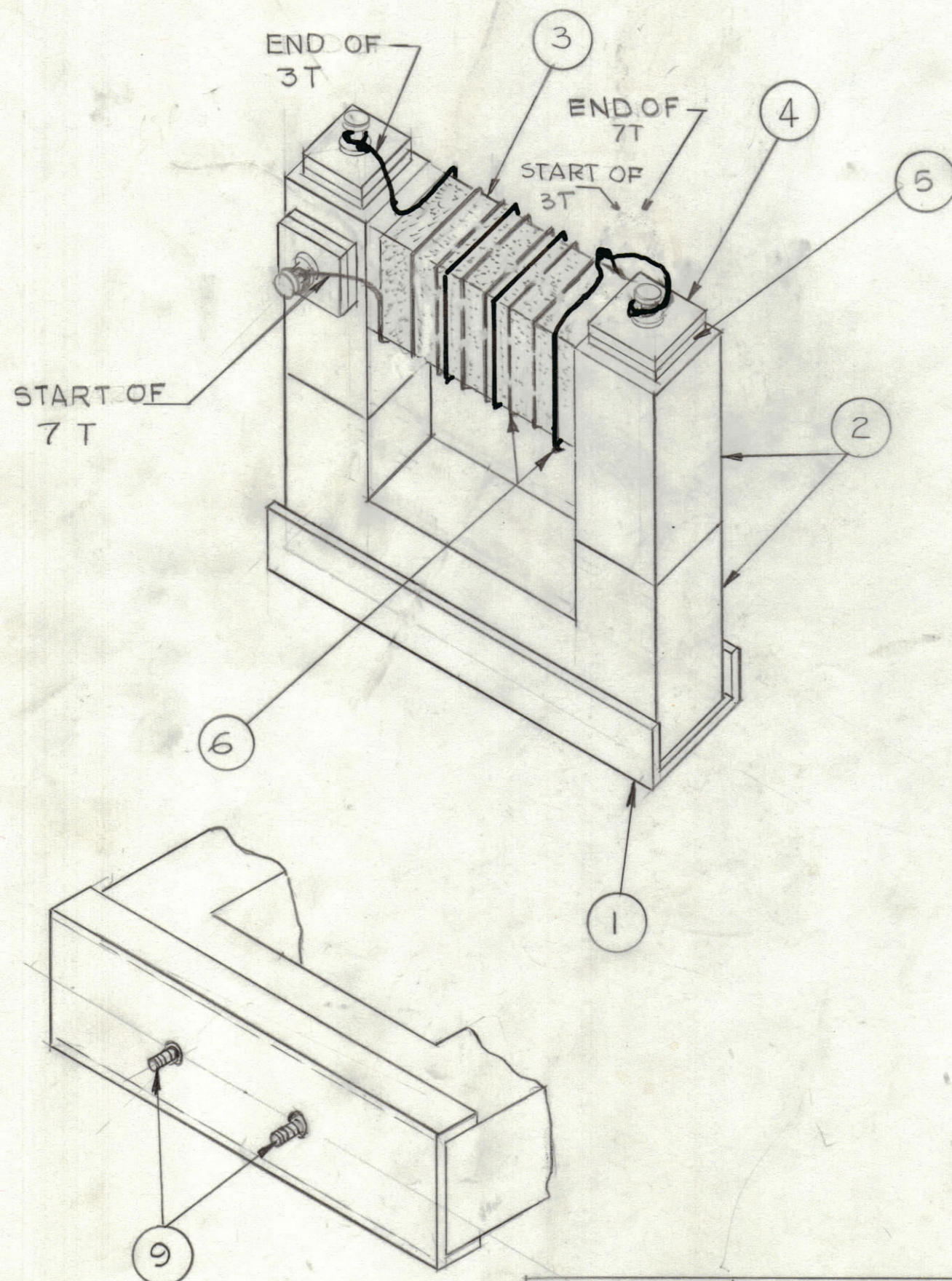
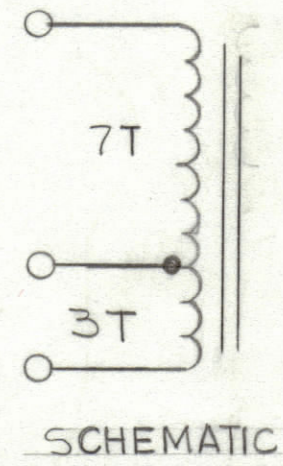

ASSEMBLY PROCEDURE:

- 1- USING ITEM 8 JOIN ITEM 2 & 1 TOGETHER AS SHOWN, WITH ITEM 9 IN PLACE.
- 2- USING ITEM 5, FASTEN TO ITEM 2 WITH ITEM 8, AS SHOWN ALLOW 24 HOURS TO CURE
- 3- USING ITEM 4, FASTEN TO ITEM 5 WITH ITEM 8 AS SHOWN
- 4- WRAP 2 TURNS ITEM 3 AROUND ITEM 2 AS SHOWN
- 5- WIND 7 TURNS ITEM 6 COUNTER CLOCKWISE AS SHOWN
- 6- WRAP 3 TURNS ITEM 3 AROUND ITEM 2 AS SHOWN
- 6 - WITH ITEM 6 WRAP THE END OF 7 WINDING TURNS AND START 3 TURNS EQUAL SPACED CLOCK WISE AS SHOWN -
- 7- FASTEN ITEM 6 TO ITEM 4 WITH ITEM 7

QTY. REQ.	ITEM	PART NO.	DESCRIPTION	SYMBOL
2	9	SCFP0440BN4	SCREW, MACHINE	
X	8	NO TMC NO.	ADHESIVE (EASTMAN 910)	
X	7	BS100	SOLDER TIN ALLOY	
X	6	WI 139-2	WIRE ELECTRICAL INSUL.	
3	5	PX1051-1	TERMINAL INSULATOR	
3	4	PX1051-2	TERMINAL INSULATORE	
X	3	TA108-5	TAPE	
2	2	CI 101-3Q1	CORE U	
1	1	MS 6559	BRACKET, TRANSFORMER	

LIST OF MATERIAL

UNLESS OTHERWISE SPECIFIED DIMENSIONS ARE IN INCHES AND INCLUDE CHEMICALLY APPLIED OR PLATED FINISHES	FINAL APPROVAL <i>DOB</i>	DATE 3/25/75
TOLERANCES ON	MECH. DES.	DATE
DECIMALS .X ± .05 .XX ± .01 .XXX ± .005	ELECT. DES. <i>MD</i>	DATE
FRACTIONS ± 1/64 ANGLES ± 0° -30'	CHECKED	DATE
	DRAWN G. De Lucia	DATE 2-27-75

THE TECHNICAL MATERIEL CORP. MAMARONECK, NEW YORK			
TRANSFORMER, RF			
SIZE	CODE IDENT. NO.	DWG NO.	ISSUE
C	82679	TR 204	A
SCALE	1:1	SHEET	OF

1	ATU-1K	ASS'Y NO.
QTY / UNIT	MODEL USED ON	
APPLICATION		
CODE		
<small>NOTICE TO PERSONS RECEIVING THIS DRAWING</small> <small>THE TECHNICAL MATERIEL CORPORATION claims proprietary right in the material disclosed hereon. This drawing is issued in confidence for engineering information only and may not be reproduced or used to manufacture anything shown hereon without permission from THE TECHNICAL MATERIEL CORPORATION to the user. This drawing is loaned for mutual assistance and is subject to recall at any time.</small>		

TR 204 A B