

REVISIONS

QTY	MODEL USED ON	ASS'Y NO.	LTR	DESCRIPTION	DATE	E.M.N.NO	DRAFT	CHKD	APPD
1	GPZ 110	A4953							

Original Release Mfg ~ GDL *

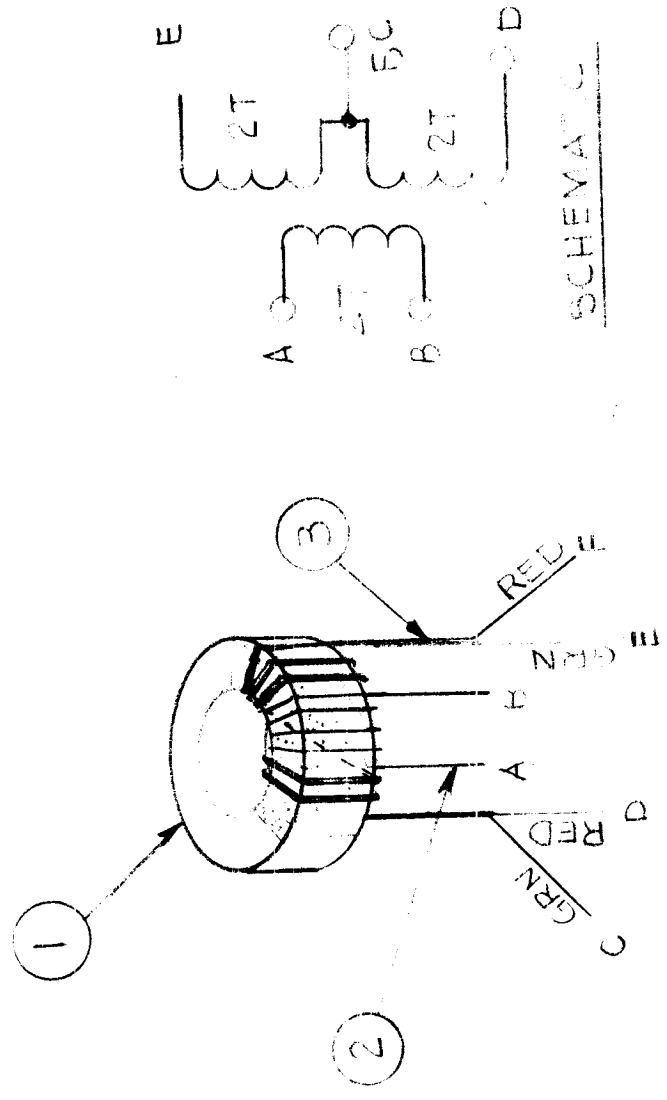

REQ'D	ITEM	PART NUMBER	DESCRIPTION	SYM.
X	5	GL130	ADHESIVE Q DOPE	
X	4	TA108-1	INS TAPE EL GL	
X	3	WI148-34-25	WIRE ELEC MAGNET	
X	2	WI141-28	WIRE ELEC MAGNET	
1	1	CJ127-7	CORE, TOROID	

UNLESS OTHERWISE SPECIFIED DIMENSIONS ARE IN INCHES AND INCLUDE CHEMICALLY APPLIED OR PLATED FINISHES

DECIMALS	FRACTIONS
.X ± .05	1/64
.XX ± .01	ANGLES
.XXX ± .005	0°-30°

MATERIAL

FINISH

FINAL APPROVAL *DB* DATE *7/12/77*

MECH. DES. DATE

ELECT. DES. DATE

CHECKED DATE

DRAWN *GD* DATE *6-27-74*

LIST OF MATERIAL

THE TECHNICAL MATERIEL CORP.
MAMARONECK, NEW YORK

XFMR PHASE DETECTOR

NOTICE TO PERSONS RECEIVING THIS DRAWING

THE TECHNICAL MATERIEL CORPORATION claims proprietary right in the material disclosed hereon. This drawing is issued in confidence for engineering information only and may not be reproduced or used to manufacture anything shown hereon without permission from THE TECHNICAL MATERIEL CORPORATION to the user. This drawing is loaned for mutual assistance and is subject to recall at any time.

SIZE	CODE IDENT. NO.	DWG NO.	ISSUE
A	82679	TR 199	1

SCALE *1* SHEET *1* OF *1*