

IF IT IS FOUND DESIRABLE TO CHANGE ANY TOLERANCE OR OTHER DETAIL SPECIFIED ON THIS DRAWING NOTIFY THE PURCHASER PROMPTLY.

MAXIMUM ALLOWABLE TOLERANCES HAVE BEEN DETERMINED AND DEVIATIONS WILL BE CAUSE FOR REJECTION. REMOVE ALL BURRS AND SHARP EDGES

TR-047A C

DIMENSIONS FOR REF. ONLY

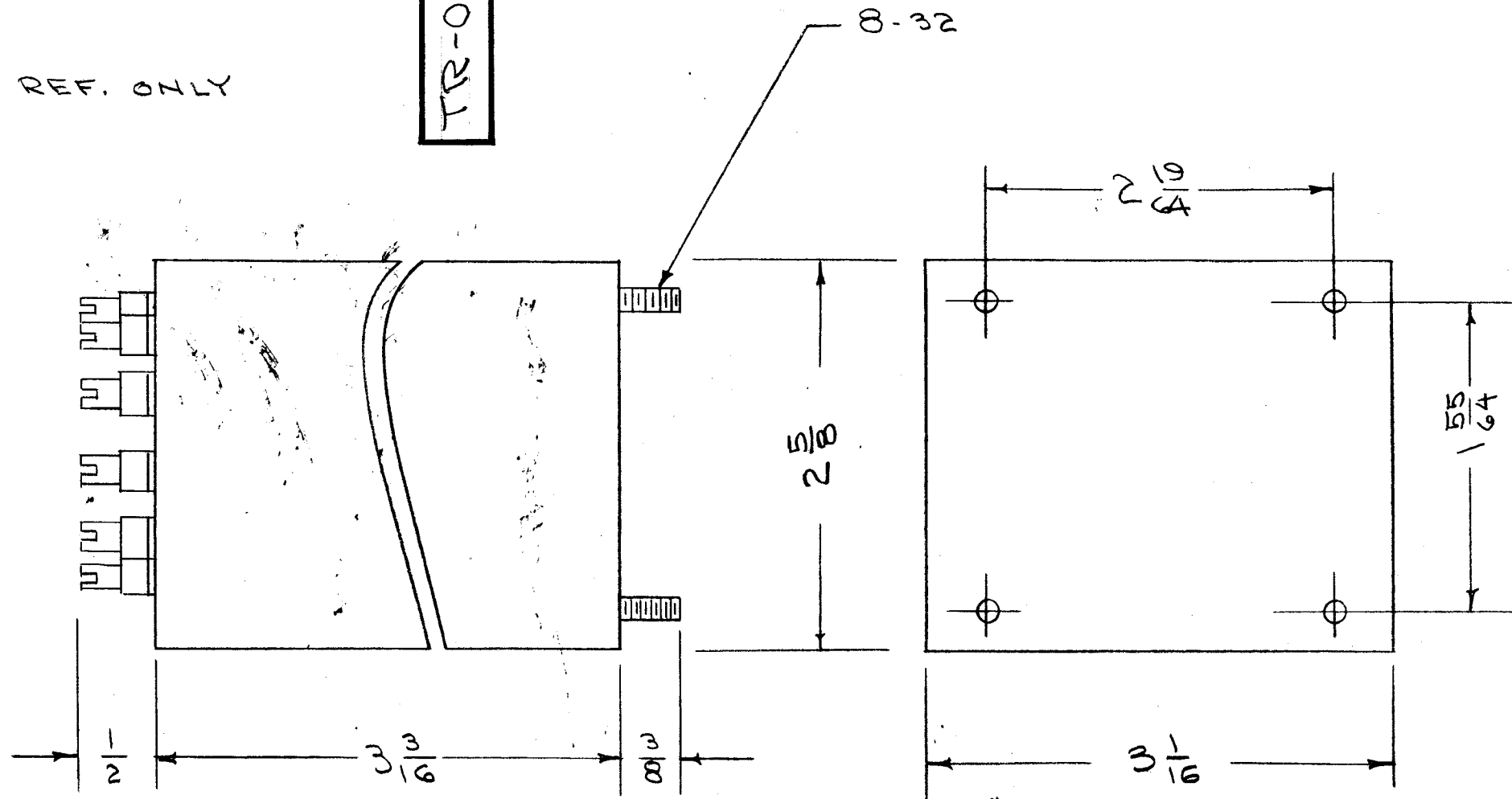
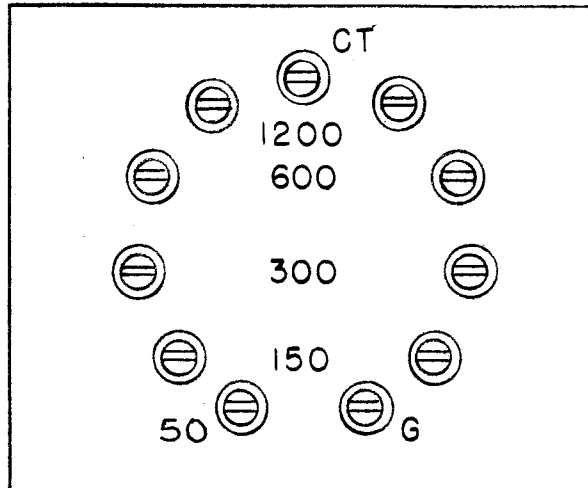

MECHANICAL SPECIFICATIONS

CASE - STEEL  
 COLOR - GRAY  
 STUDS - 8-32 X 3/8

TERMINALS - CERAMIC

ELECTRICAL SPECIFICATIONS

INPUT - 50 Ω UNBAL.  
 OUTPUT: 150, 300, 600, 1200 Ω BAL.

| C     |      | TERM 50 WAS 70-Ω ON ELECT. SPEC. INPUT WAS 70-Ω ON MECH. SPECS. COMPOUND DELETED | 2-28-67 | 17873   | C.D.L. | JCS     | 10        |
|-------|------|--|---------|---------|--------|---------|-----------|
| B     | 1    | DIM. CHGD FROM 2.555 X 3.000 TO 2-5/8 X 3-1/16 AS PER BX-127                     | 1/5/58  | 2       | 16     | File    | Am        |
| A     | 1    | 1200 Ω TAP ADDED   | 3/1/55  | 1       | File   | File    | MS        |
| ISSUE | ITEM | CHANGED FROM   | DATE    | CN. NO. | DRAFTS | CHECKER | ENG. APP. |

|            |   |   |
|------------|---|---|
| TOLERANCES |   | SCALE:  |
| ALL OTHERS | DEC. DIM. ±<br>FRAC. DIM. ±<br>ANGULAR DIM. ± | DRILL, PUNCH, COMMERCIAL STOCK SIZES AND MANUFACTURERS TOLERANCES ARE NOT INCLUDED. |

|               |         |             |            |      |
|---------------|---------|-------------|------------|------|
| REQ. PER UNIT | MODEL   | PROJECT NO. | ASS'Y. NO. | DATE |
|               | USED ON |             |            |      |

| REQ. | ITEM | PART NO. | DESCRIPTION  | SYMBOL                        |
|------|------|----------|--|-------------------------------|
|      |      |          | THE TECHNICAL MATERIEL CORP.<br>MAMARONECK, NEW YORK |                               |
|      |      |          | TRANSFORMER, R.F.                                    |                               |
|      |      |          | PHYSICAL SPECIFICATIONS                              |                               |
|      |      |          | DESIGN: 4/11/55                                      | W.D.Z.                        |
|      |      |          | DRAWN: <i>Am</i>                                     | ELEC. DES. APP. <i>Am</i>     |
|      |      |          | CHECKED: <i>Am</i>                                   | MECH. DES. APP. <i>W.D.Z.</i> |
|      |      |          | FINAL APPROVAL                                       |                               |
|      |      |          | 4A-921   | TR-047A C.                    |
|      |      |          | FINISH & SPEC. NO.                                   |                               |