

STANDARD DRAWING

B
TI 105

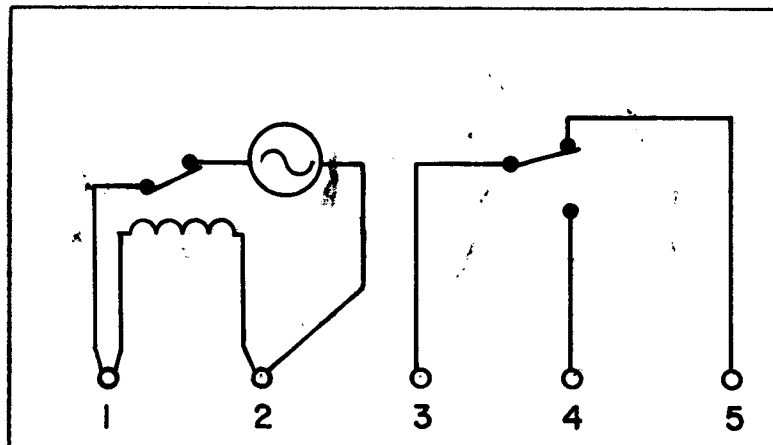
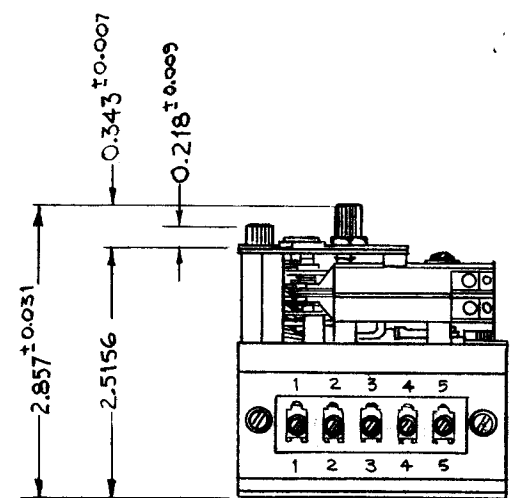
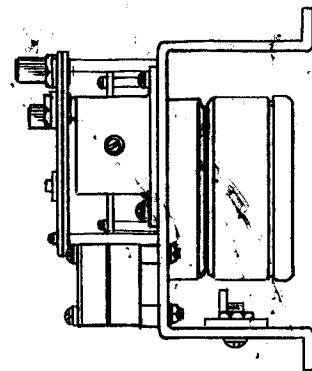
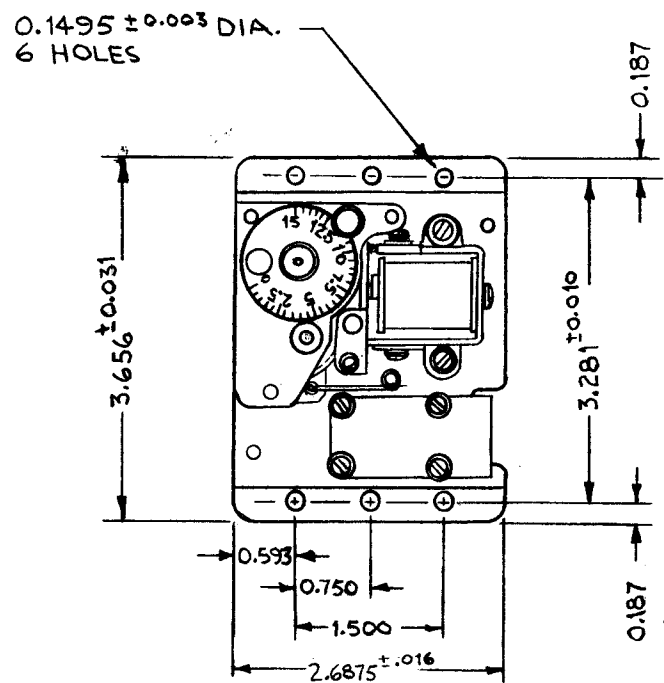

WIRING DETAIL

REVISIONS						
SYM	DESCRIPTION	DATE	E.M.N. NO.	DRAFT	CHKD	APPD
X	EXPERIMENTAL RELEASE	11/16/66	X	RME		
Ø	ORIGINAL RELEASE FOR PRODUCTION	12/1/66	Ø	CV		
A	P/N CHART ADD.	11/26/69	19671	KH	ØW	FB ØA
B	ADDED - 3 AND - 4 TO P/N CHT.	10/6/70	19992	GE	W	TPCW

SPECIFICATION

TIME RANGE: 5 MINUTES
 DIAL DIVISION: 10 SEC
 ADJUSTMENT RANGE SETTING: 30 SEC (MIN), 5 MIN. (MAX)
 MOTOR RATING: SEE CHART
 REPEAT ACCURACY: WITHIN 2 % OF TIME RANGE
 SWITCH RATING: CONT. ARRANGEMENT - SPDT
 CURRENT & VOLTAGE - 10AMPS @ 125VAC
 5AMPS @ 250VAC
 RESISTIVE LOAD

TYPE CLUTCH: DIRECT
 GEAR MATERIAL: CASE HARDENED STEEL
 LIFE: MECHANICAL LIFE - 1,000,000 OPERATIONS

TMC P/N.	MOTOR RATING	MFGR P/N.
TI 105-1	220/240 V 60 HZ	471
TI 105-2	220/240 V 50 HZ	471-A
TI 105-3	115 V 60 HZ	471-A
TI 105-4	115 V 50 HZ	471-A

REQ'D.	ITEM	PART NUMBER	DESCRIPTION	SYMBOL
--------	------	-------------	-------------	--------

LIST OF MATERIAL

MATERIAL		THE TECHNICAL MATERIEL CORP. MAMARONECK, NEW YORK			
FINISH		TITLE TIMER, ADJUSTABLE			
UNLESS OTHERWISE SPECIFIED DIMENSIONS ARE IN INCHES AND INCLUDE CHEMICALLY APPLIED OR PLATED FINISHES		DRAWN RME	DATE 11-18-66	FINAL APPROV. <i>[Signature]</i>	DATE 12/1/66
DECIMALS .X ± .05 .XX ± .01 .XXX ± .005		CHECKED <i>[Signature]</i>	DATE 11/30/66	DATE 12/1/66	
FRACTIONS ± 1/64 ANGLES ± 0° 30'		ELECT. DES. <i>[Signature]</i>	DATE 12/1/66	DATE 12/1/66	
TOLERANCES		MECH. DES. <i>[Signature]</i>	DATE	DATE	
SCALE		SHEET		REV. LTR.	

Q'TY./UNIT	MODEL USED ON	ASS'Y. NO.
SCALE	CODE	5401-46

THE CONTENTS OF THIS DRAWING ARE THE EXCLUSIVE PROPERTY OF THE TECHNICAL MATERIEL CORP. ITS UNAUTHORIZED USE OR REPRODUCTION IN WHOLE OR IN PART IS STRICTLY FORBIDDEN.

NOTES