

IF IT IS FOUND DESIRABLE TO CHANGE ANY TOLERANCE OR OTHER DETAIL SPECIFIED ON THIS DRAWING NOTIFY THE PURCHASER PROMPTLY.		DIMENSIONS IN INCHES UNLESS OTHERWISE SPECIFIED					
MAXIMUM ALLOWABLE TOLERANCES HAVE BEEN DETERMINED AND DEVIATIONS WILL BE CAUSE FOR REJECTION. REMOVE ALL BURRS AND SHARP EDGES.							
ISSUE	ITEM	CHANGED FROM	DATE	CN. NO.	DRAFTS	CHECKER	ENG. APP.
Ø		REL. TO PROD	JAN 31/68		RPL	JW	[Signature]

REQ.	ITEM	PART NO.	DESCRIPTION	SYMBOL
------	------	----------	-------------	--------

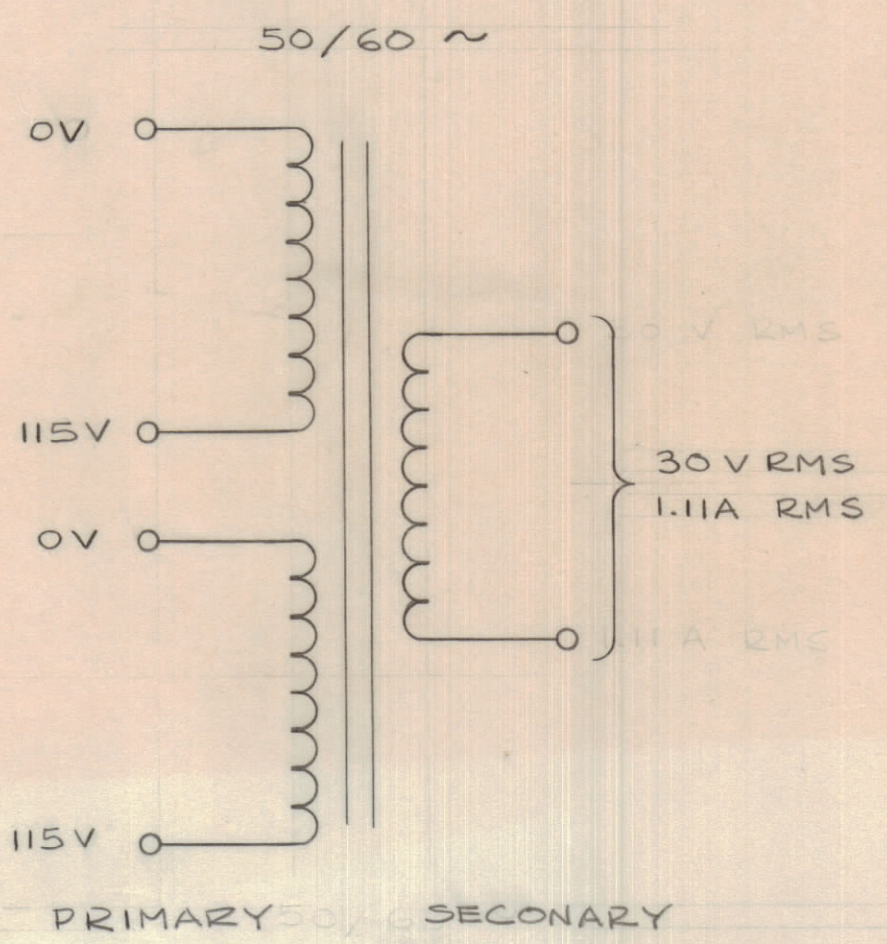
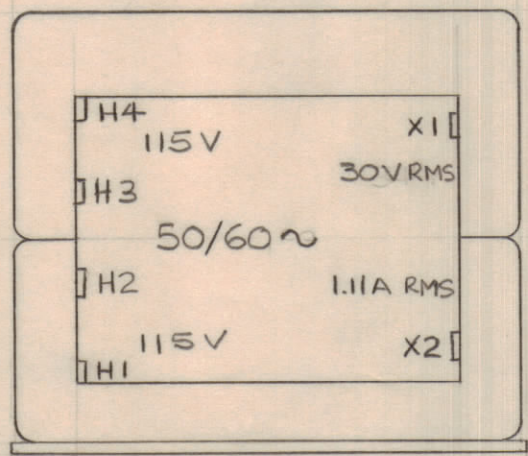
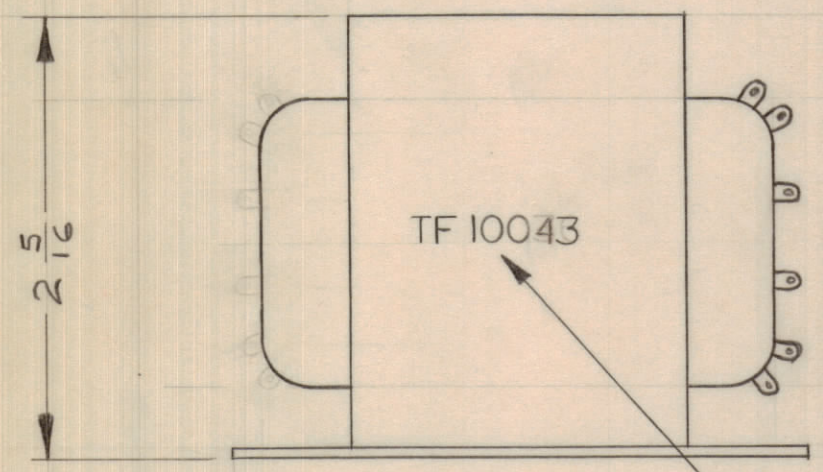

TF10043 Ø

STAMP TMC PART NO. 1/8 GOTHIC HIGH

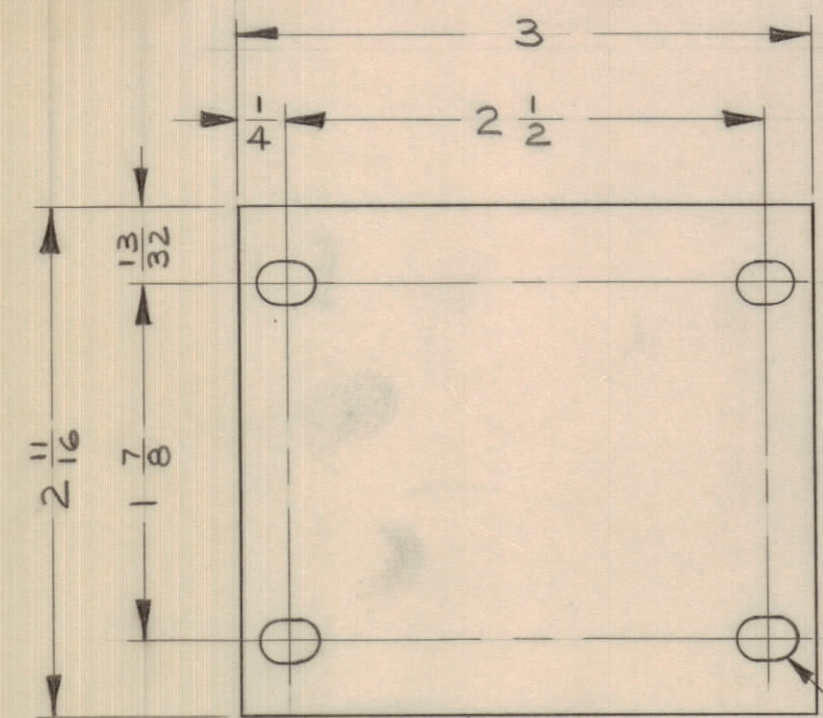

1/4 X 3/8 SLOTS (4 REQ'D)

- NOTES:**
- (1) PRIMARY: 115 / 230 VAC
 - (2) SECONDARY: 30V RMS AT 1.11A RMS
 - (3) CONSTRUCTION: FLEXI-CORE

MFGR S10045-23
MFGR PART NO. T81041

TOLERANCES		SCALE:
ALL OTHERS	DEC. DIM. ± .XX FRAC. DIM. ± 1/64 ANGULAR DIM. ± 0° 30'	.X=.05 .XX=.01 .XXX=.005
		DRILL, PUNCH, COMMERCIAL STOCK SIZES AND MANUFACTURERS TOLERANCES ARE NOT INCLUDED.

AMC 21	070/68	JAN 31/68
MODEL	PROJECT NO.	DATE
	ASS'Y. NO.	

STOCK SIZE		TMC (Canada) LIMITED OTTAWA ONTARIO	
MATERIAL		TRANSFORMER POWER	
WEIGHT PER PC.		RPL	[Signature]
TYPE & TEMPER.		DRAWN	ELEC. DES. APP. [Signature]
HEAT TREAT. SPEC.		CHECKED	MECH. DES. APP. [Signature]
BLACK EPOXY DIP		FINAL APPROVAL [Signature]	
FINISH & SPEC. NO.		TF10043 Ø	