

IF IT IS FOUND DESIRABLE TO CHANGE ANY TOLERANCE OR OTHER DETAIL SPECIFIED ON THIS DRAWING NOTIFY THE PURCHASER PROMPTLY.

STANDARD DRAWING

TE 146 C

MAXIMUM ALLOWABLE TOLERANCES HAVE BEEN DETERMINED AND DEVIATIONS WILL BE CAUSE FOR REJECTION. REMOVE ALL BURRS AND SHARP EDGES

USED ON

MODEL	PROJECT NO.	ASS'Y. NO.	DATE
-------	-------------	------------	------

NOTE THAT DASH NO. INDICATES NO. OF LUGS

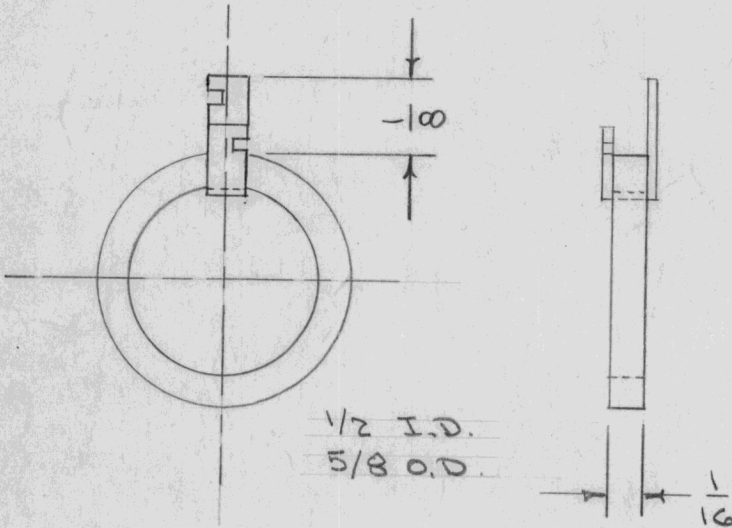

1/2 I.D.
5/8 O.D.

1/16

DIMENSIONS FOR REF. ONLY

NOTE: PURCHASE TE 146-4 ONLY
AND MODIFY AS REQUIRED.

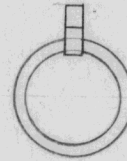

TE 146-1

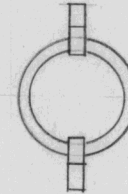

TE 146-2S
(STRAIGHT)

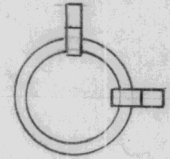

TE 146-2A
(ANGLED)

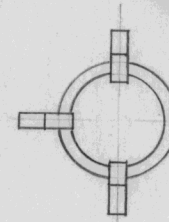

TE 146-3

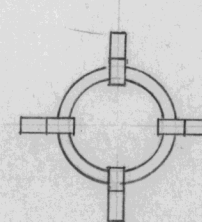

TE 146-4

REQ.	ITEM	PART NO.	DESCRIPTION	SYMBOL
			THE TECHNICAL MATERIEL CORP. MAMARONECK. NEW YORK	
STOCK SIZE			COLLAR & LUG	
MATERIAL		WEIGHT PER PC.		
TYPE & TEMPER			COND. 12-8-54	HT.
			DRAWN	ELEC. DES. APP. MECH. DES. APP.
			P.L.K.	G.T.O.
HEAT TREAT. SPEC.			CHECKED	FINAL APPROVAL
			TE 146 C	
FINISH & SPEC. NO.				

C		ADDED PURCH. NOTE, DELETE REF. CAMBRIDGE THERMIONICS, ADDED S401-167	7-20-66	16591	RME	<i>CF</i>	<i>MM</i>
B	2	Ref: 1697 was X2049	2-6-58	2	<i>JMB</i>	<i>PH</i>	
A	1	MATERIAL CLARIFIED	12-7-56	1	<i>JMB</i>	<i>PH</i>	
ISSUE	ITEM	CHANGED FROM	DATE	CN. NO.	DRAFTS	CHECKER	ENG. APP.
TOLERANCES			SCALE S401-167(1697)				
ALL OTHERS	DEC. DIM. ± FRAC. DIM. ± ANGULAR DIM. ±		DRILL, PUNCH, COMMERCIAL STOCK SIZES AND MANUFACTURERS TOLERANCES ARE NOT INCLUDED.				