

IF IT IS FOUND DESIRABLE TO CHANGE ANY TOLERANCE OR OTHER DETAIL SPECIFIED ON THIS DRAWING NOTIFY THE PURCHASER PROMPTLY.

MAXIMUM ALLOWABLE TOLERANCES HAVE BEEN DETERMINED AND DEVIATIONS WILL BE CAUSE FOR REJECTION. REMOVE ALL BURRS AND SHARP EDGES

TE-123 \emptyset

USED ON

MODEL	PROJECT NO.	ASS'Y. NO.	DATE
	178	CA-152	2-16-53
	178	CA-153	2-16-53

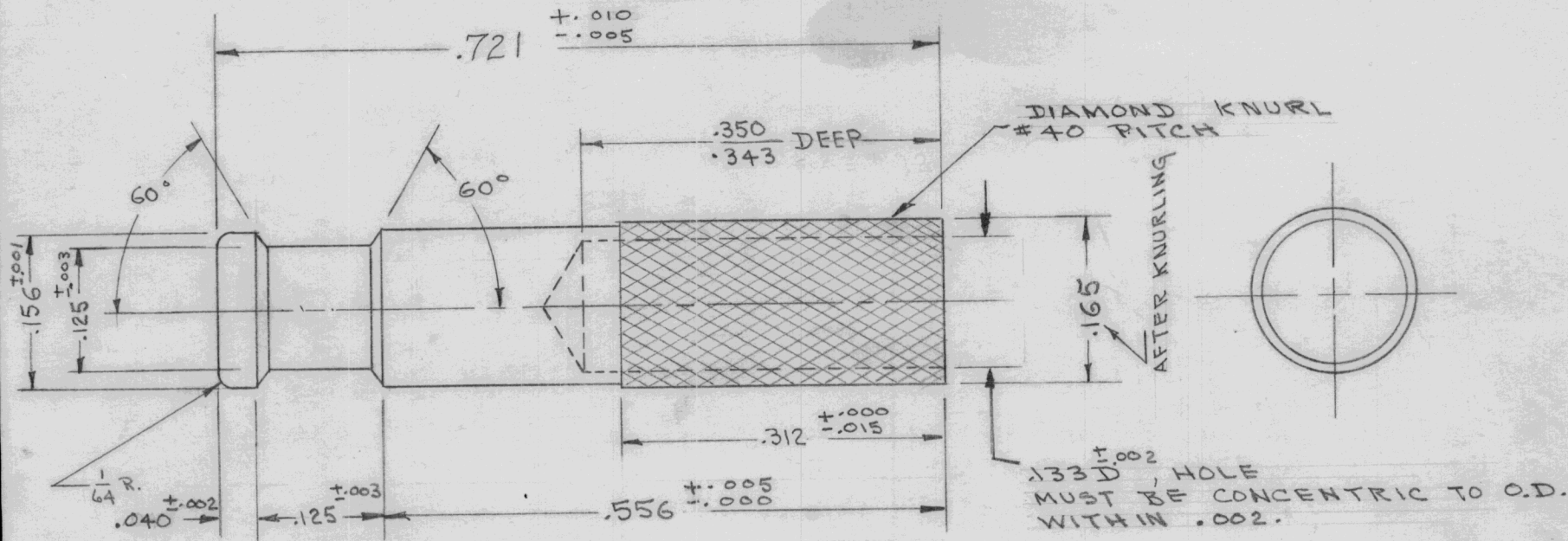

REQ.	ITEM	PART NO.	DESCRIPTION	SYMBOL
		5/32 D	THE TECHNICAL MATERIEL CORP. MAMARONECK. NEW YORK	
		STOCK SIZE		
		BRASS ROD	TERMINAL, SOLDER	
		MATERIAL		
		WEIGHT PER PC.		
		SCREW STOCK SAE #72		
		TYPE & TEMPER	WDA 2-16-53	
		HEAT TREAT. SPEC.	DRAWN	ELEC. DES. APP. <i>[Signature]</i> MECH. DES. APP. <i>[Signature]</i>
		FINISH & SPEC. NO.	C.D.D. 2-16-52	SCALE <i>[Signature]</i> 9/26/69
			CHECKED	FINAL APPROVAL
				TE-123 \emptyset

\emptyset	ORIGINAL RELEASE	9/26/69					
ISSUE	ITEM	CHANGED FROM	DATE	CN. NO.	DRAFTS	CHECKER	ENG. APP.
TOLERANCES			SCALE				
ALL OTHERS	DEC. DIM. \pm FRAC. DIM. \pm ANGULAR DIM. \pm		DRILL, PUNCH, COMMERCIAL STOCK SIZES AND MANUFACTURERS TOLERANCES ARE NOT INCLUDED.				

IF IT IS FOUND DESIRABLE TO CHANGE ANY TOLERANCE OR OTHER DETAIL SPECIFIED ON THIS DRAWING NOTIFY THE PURCHASER PROMPTLY.

TE - 123

MAXIMUM ALLOWABLE TOLERANCES HAVE BEEN DETERMINED AND DEVIATIONS WILL BE CAUSE FOR REJECTION. REMOVE ALL BURRS AND SHARP EDGES

USED ON

MODEL

PROJECT NO.

ASS'Y. NO.

DATE

CA-152

CA-153

CA-162

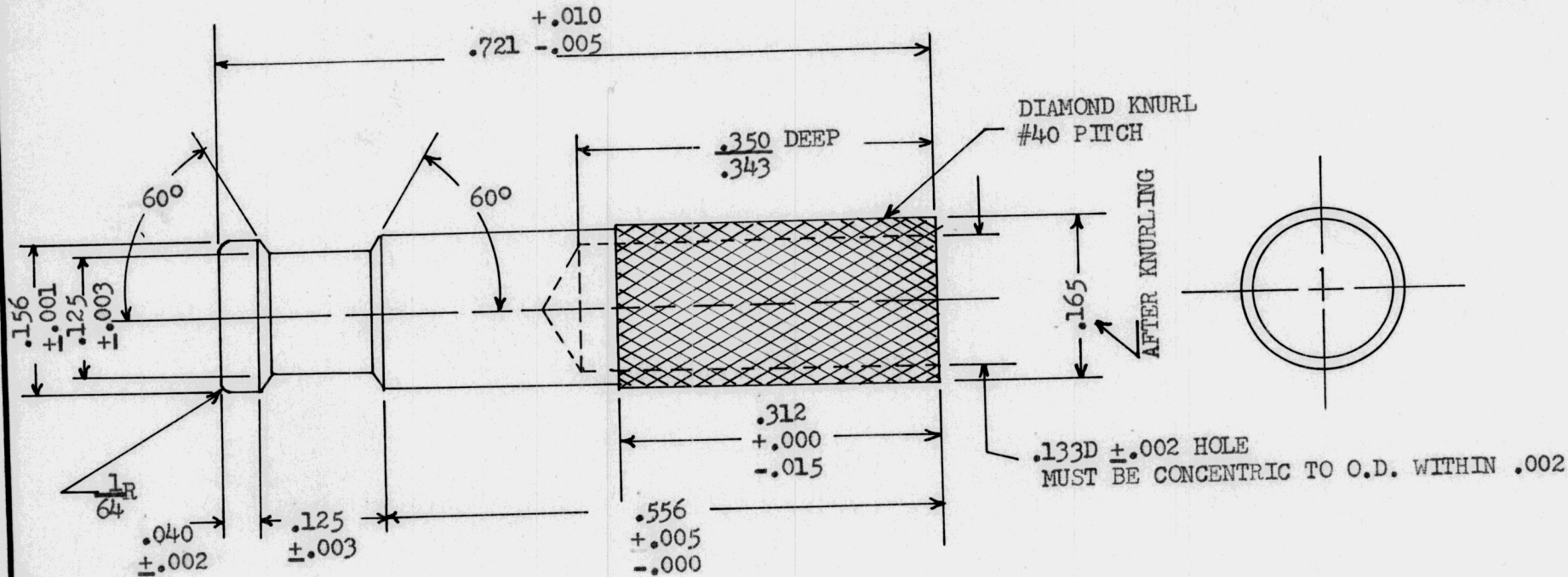

REQ.	ITEM	PART NO.	DESCRIPTION	SYMBOL
		5/32 D	TMC (Canada) LIMITED OTTAWA ONTARIO	
		STOCK SIZE		
		BRASS ROD	TERMINAL, SOLDER	
		MATERIAL	WEIGHT PER PC.	
		SCREW STOCK SAE #72		
		TYPE & TEMPER	DF 20/6/58	
			DRAWN	ELEC. DES. APP.
			CHECKED	MECH. DES. APP.
		HEAT TREAT. SPEC.	FINAL APPROVAL	
		BRIGHT NICKEL	TE - 123	
		FINISH & SPEC. NO.		

ISSUE	ITEM	CHANGED FROM	DATE	CN. NO.	DRAFTS	CHECKER	ENG. APP.

TOLERANCES

SCALE

ALL OTHERS

DEC. DIM. \pm
FRAC. DIM. \pm
ANGULAR DIM. \pm

DRILL, PUNCH, COMMERCIAL STOCK SIZES AND MANUFACTURERS TOLERANCES ARE NOT INCLUDED.