

SW-325 0

**REVISIONS**

SYM	DESCRIPTION	DATE	E.M.N. NO.	DRAFT	CHKD	APPD
0	ORIGINAL RELEASE FOR PRODUCTION	3-26-64		A.M.		

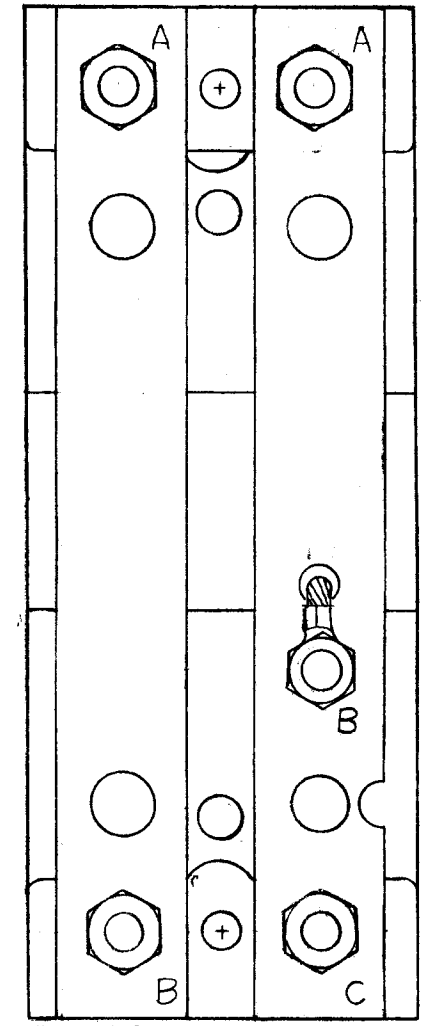
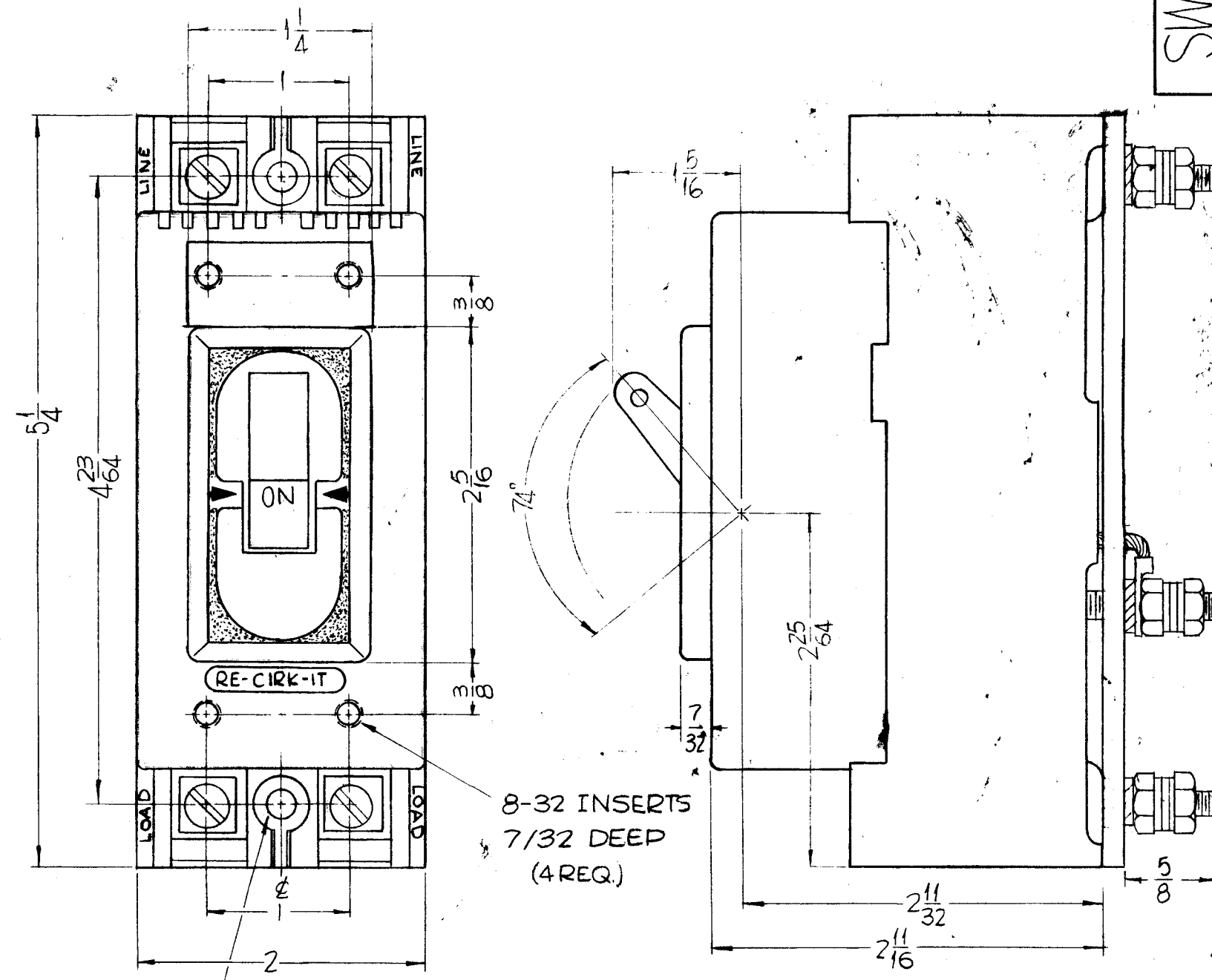

**ELECTRICAL SPECS:**

50 AMPS, 250VAC, PLAIN SWITCH, POLE #2  
 120 V AC, INST. TRIP, SHUNT TRIP COIL,  
 POLE #1.  
 50/60 CYCLES

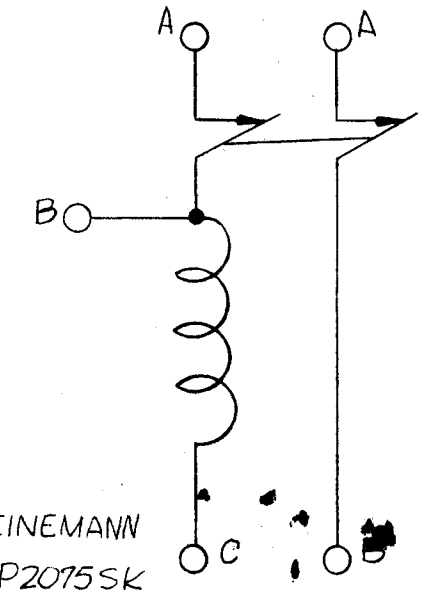

REF: HEINEMANN  
 CAT. NO. P2075SK

MTG. HOLES FOR  
 10-32 SCREWS  
 (2 REQ.)

**NOTES**

1	GPT-200K	AX-399
Q'TY./UNIT	MODEL USED ON	ASS'Y. NO.
SCALE	CODE	

THE CONTENTS OF THIS DRAWING ARE THE EXCLUSIVE PROPERTY OF THE TECHNICAL MATERIEL CORP. ITS UNAUTHORIZED USE OR REPRODUCTION IN WHOLE OR IN PART IS STRICTLY FORBIDDEN.

REQ'D.	ITEM	PART NUMBER	DESCRIPTION	SYMBOL
--------	------	-------------	-------------	--------

**F. BUDETTI LIST OF MATERIAL**

MATERIAL	THE TECHNICAL MATERIEL CORP. MAMARONECK, NEW YORK		
FINISH	TITLE CIRCUIT BREAKER PA. FIL.		

UNLESS OTHERWISE SPECIFIED DIMENSIONS ARE IN INCHES AND INCLUDE CHEMICALLY APPLIED OR PLATED FINISHES		DRAWN <i>SRG</i>	DATE 2-5-63	FINAL APPROVAL <i>RAC</i>	DATE
		CHECKED <i>ACB</i>	DATE 2/12/64		
		MECH. DES. <i>SRG</i>	DATE 2/12/64	SW-325	0
DECIMALS .X ± .05 .XX ± .01 .XXX ± .005	TOLERANCES	FRACTIONS ± 1/64 ± 0° 30'	SHEET		