

REQ. PER UNIT	USED ON		
	MODEL	ASS'Y. NO.	DATE
1	RTF		1-20-56
1	RTF-2	MULT	11-20-58

SW-179

A

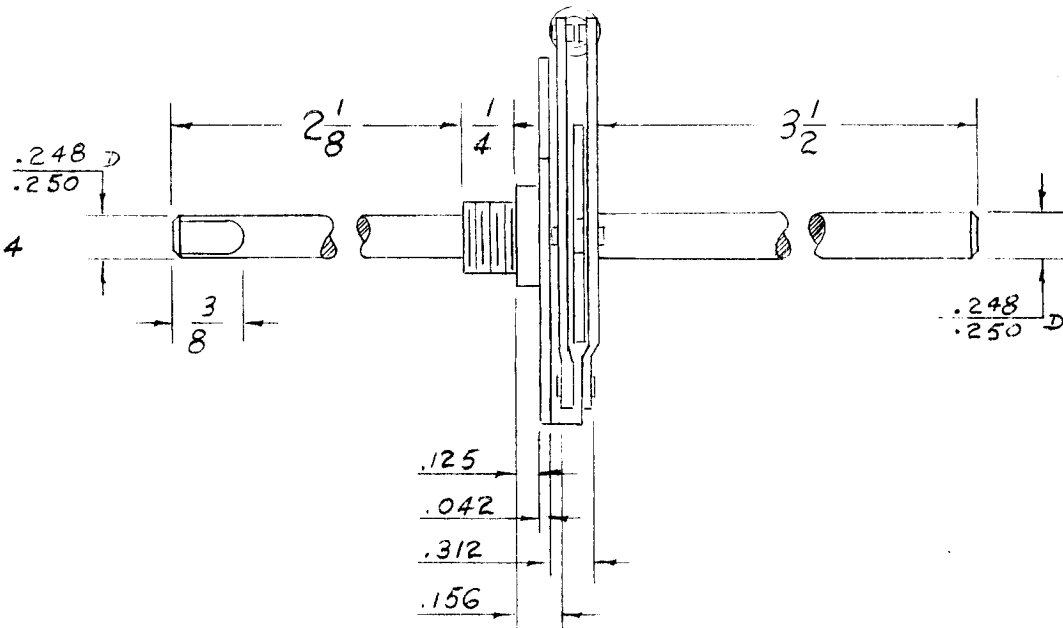
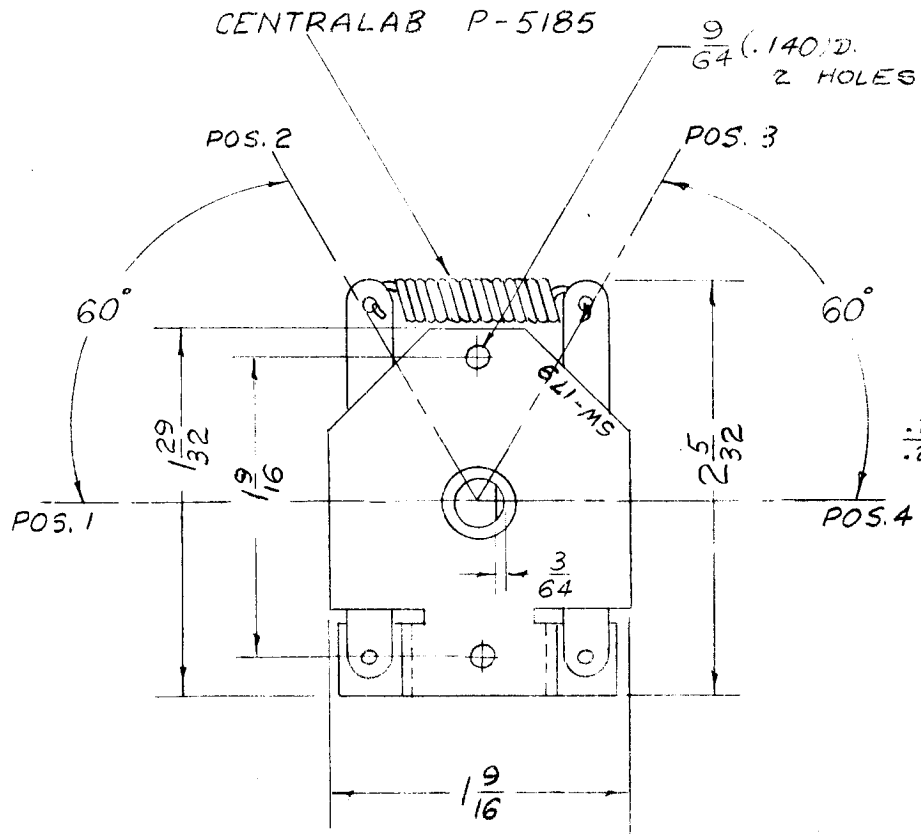

NOTE:

POSITIONS & STOP ARRANGEMENT
4 POS. 60° CLOVER LEAF INDEX.

REF. CENTRALAB TYPE G INDEX.

REQ.	ITEM	PART NO.	DESCRIPTION				SYMBOL
			THE TECHNICAL MATERIEL CORP.				
			MAMARONECK, NEW YORK				
			STOCK SIZE				
			STEEL				
			MATERIAL				
A	1	9/64" WAS 1/8	3-2-56	1	<i>JAS</i>	<i>W</i>	
ISSUE	ITEM	CHANGED FROM	DATE	CH. NO.	DRAFTS	CHECKER	ENG. APP.
TOLERANCES			SCALE: <i>H</i>				
DEC. DIM. ± .005			MAXIMUM ALLOWABLE TOLERANCES HAVE BEEN DETERMINED AND ANY DEVIATIONS WILL BE CAUSE F R REJECTION. REMOVE ALL BURRS AND SHARP EDGES				
FRAC. DIM. ± Y64							
ANGULAR DIM. ± Y2°							
TYPE & TEMPER		HEAT TREAT. SPEC.	DRAWN	CHECKED	FINAL APPROVAL		
S-105 CAD. PLATE			<i>O.I.P.</i>	<i>W</i>	SW-179		
FINISH & SPEC. NO.		ELEC. DES. APP.	MECH. DES. APP.				