

SW-174 A

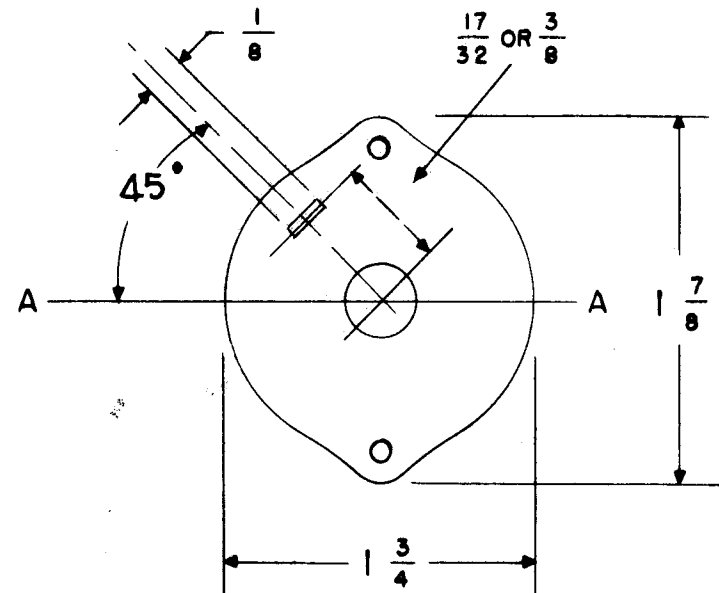

FRONT & REAR SECTIONS VIEWED FROM FRONT OR KNOB END OF SWITCH IN EXTREME COUNTER CLOCKWISE POSITION

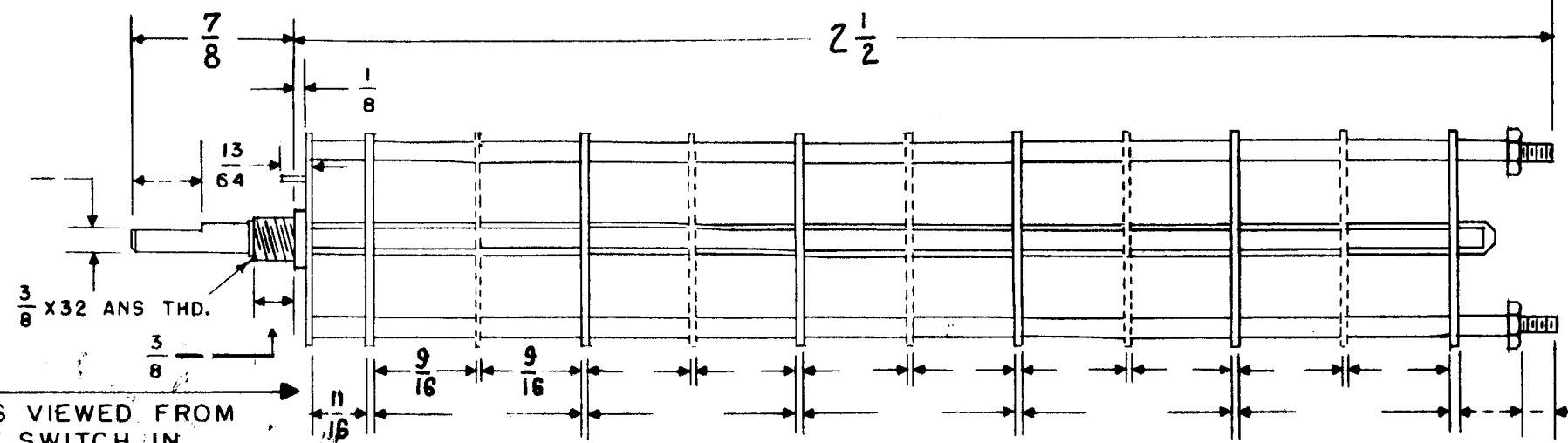

DRAW IN FLAT ON ABOVE SHAFT IN EXTREME COUNTER CLOCKWISE POSITION AND SHOW ANGLE IN REFERENCE TO LINE A-A

NUMBER OF SECTIONS 2
 NUMBER OF POSITIONS 3
 ANGLE OF THROW _____ (30° OR 60°)

PART NUMBER SW-174
 STAMP ON FRONT PLATE YES X NO _____

CONTACTS & ROTORS: (IF NOT SPECIFIED, SHORTING TYPE WILL BE SUPPLIED)
 SHORTING _____ NON SHORTING X

MATERIAL: (IF NOT SPECIFIED, SILVER PLATED BRASS WILL BE SUPPLIED)
 SILVER PLATED BRASS X SILVER ALLOY _____

INSULATION: BAKELITE _____ CERAMIC _____
 SPECIFY IMPREGNATION IF REQUIRED _____

FINISH REQUIREMENTS: COMMERCIAL X ARMY _____ NAVY _____
 SALT TEST (IF ANY GIVE DETAILS) _____

HARDWARE: SUPPLY
 _____ 3/8-32 NUTS _____ ACROS FLATS MAT. _____ PLATING _____
 _____ 3/8 INT TOOTH LOCKWASHERS MAT. _____ PLATING _____

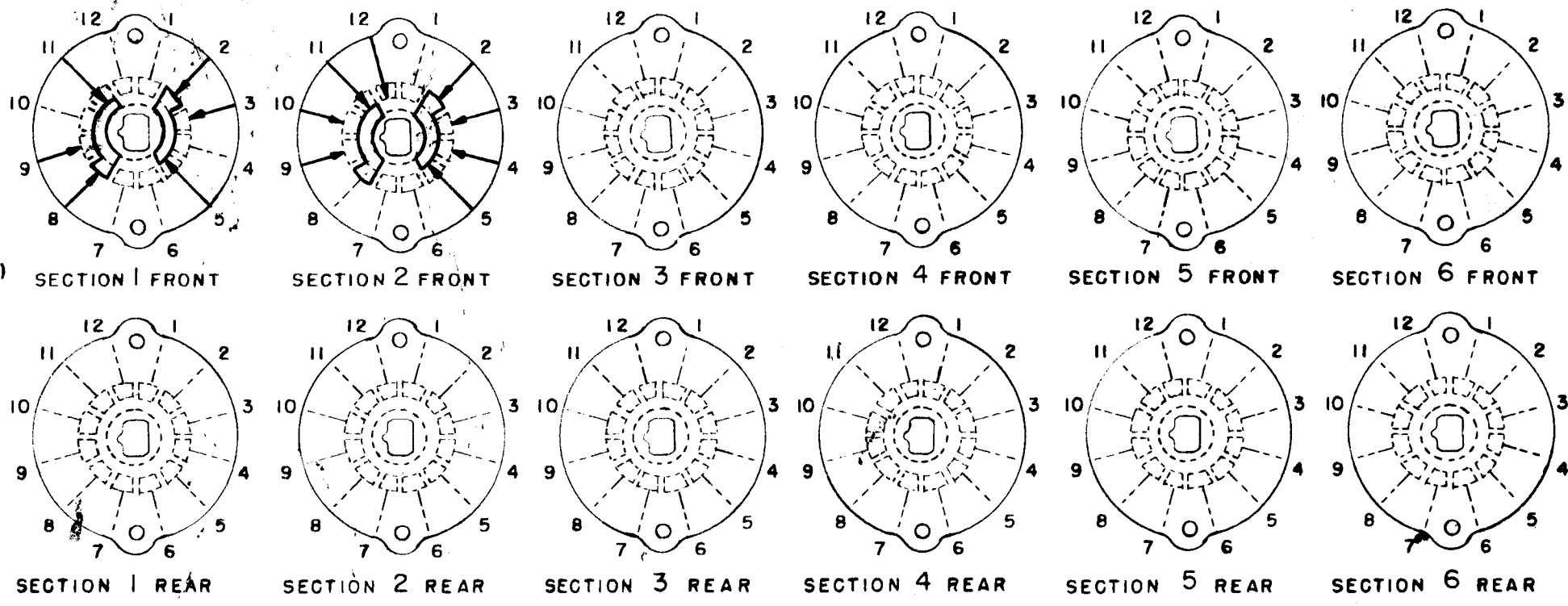

SYMBOLS USED IN MARKING PRINT →

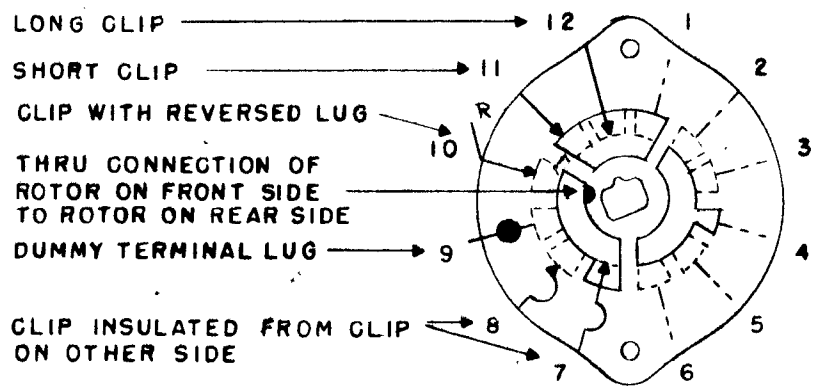

OAK SWITCH
 TYPE - H HC DH DHC QH
 QDH QHC QDHC
 (CIRCLE DESIRED TYPE)

ISSUE	ITEM	CHANGED FROM	DATE	CH. NO.	DRAFTS	CHECKER	ENG. APP.
4	1	REDRAWN NO REVISION	10/20/58				

TOLERANCES: DEC. DIM. ±, FRAC. DIM. ±, ANGULAR DIM. ±
 SCALE: _____
 MAXIMUM ALLOWABLE TOLERANCES HAVE BEEN DETERMINED AND ANY DEVIATIONS WILL BE CAUSE FOR REJECTION. REMOVE ALL BURRS AND SHARP EDGES

OUTLINE ROTOR BLADES AS SHOWN ABOVE WITH SWITCH IN EXTREME COUNTER-CLOCKWISE POSITION

REQ. PER UNIT	MODEL	PROJECT NO.	ASSY. NO.	DATE

REQ. ITEM	PART NO.	DESCRIPTION	SYMBOL
THE TECHNICAL MATERIEL CORP. MAMARONECK, NEW YORK			
SWITCH, CW-FS			
TYPE & TEMPER		HEAT TREAT. SPEC.	DRAWN
FINISH & SPEC. NO.		ELEC. DES. APP.	MECH. DES. APP.

SW-174 A