

ZONE		SYM	DESCRIPTION	DATE	E.M.N. NO.	DRAFT	CHKD	APPD
REVISIONS								

**NOTICE TO PERSONS RECEIVING THIS DRAWING**

THE TECHNICAL MATERIEL CORPORATION claims proprietary right in the material disclosed hereon. This drawing is issued in confidence for engineering information only and may not be reproduced or used to manufacture anything shown hereon without permission from THE TECHNICAL MATERIEL CORPORATION to the user. This drawing is loaned for mutual assistance and is subject to recall at any time.

Property of:  
THE TECHNICAL MATERIEL CORPORATION  
MAMARONECK, NEW YORK

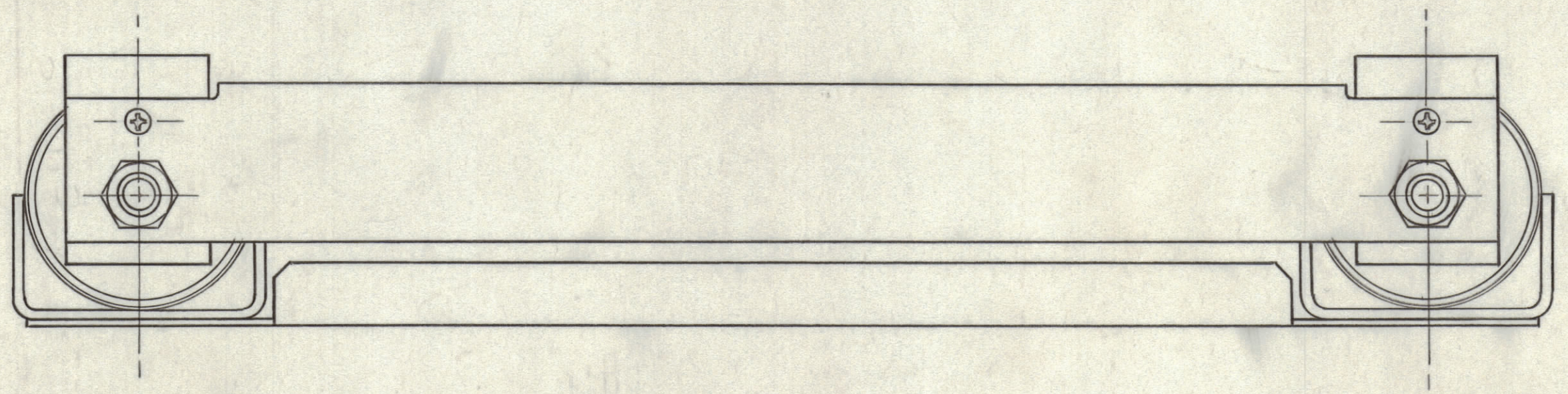
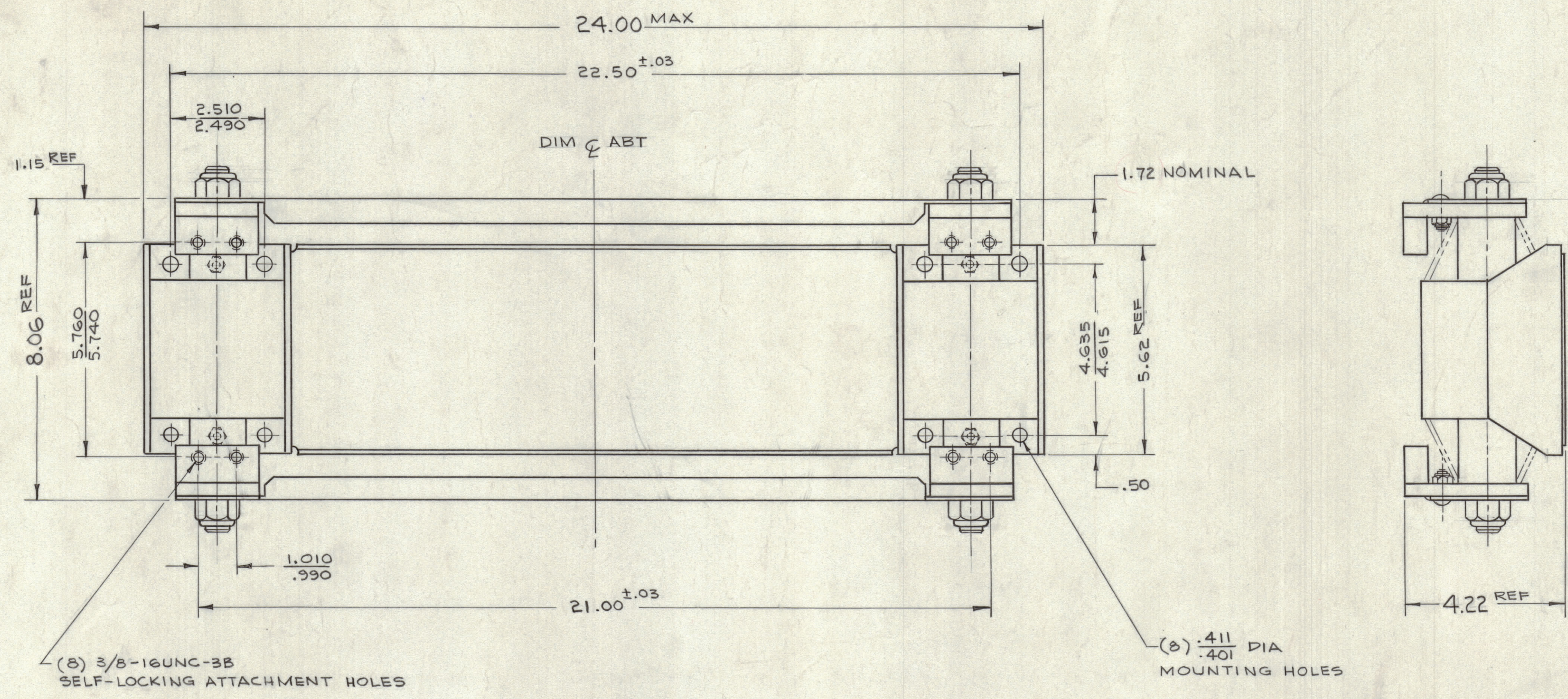

**NOTES:**

1. CONSTRUCTION IS FUSION WELDED UNLESS OTHERWISE SHOWN.
2. PRIMARY STRUCTURAL PARTS ARE STEEL, FINISH: APPLY PRIMER AND ONE COAT OF TEXTURED BLUE-VINYL PER TMC SPEC S-520.
3. SECONDARY PARTS ARE: STEEL, FINISH: CADMIUM PLATE, STAINLESS STEEL; FINISH: PASSIVATE.

SH-113

REQ'D.	ITEM	PART NUMBER	DESCRIPTION	SYMBOL
KRUJ LIST OF MATERIAL				
MATERIAL		THE TECHNICAL MATERIEL CORP. MAMARONECK, NEW YORK		
FINISH		TITLE STABILIZER		
QTY.	UNIT	MODEL USED ON	ASSY. NO.	
3		DDR-5		
SCALE	NO SCALE	CODE	S401-152(W1345-15A2)	
THE CONTENTS OF THIS DRAWING ARE THE EXCLUSIVE PROPERTY OF THE TECHNICAL MATERIEL CORP. ITS UNAUTHORIZED USE OR REPRODUCTION IN WHOLE OR IN PART IS STRICTLY FORBIDDEN.		DECIMALS	TOLERANCES	FRACTIONS
		X ± .05	± 1/64	
		.XX ± .01	ANGLES	
		.XXX ± .005	± 0° 30'	
DRAWN	DATE	FINAL APPROVAL	DATE	
<i>[Signature]</i>	10-19-62	<i>[Signature]</i>	2/2/63	
CHECKED	DATE			
<i>[Signature]</i>	2/2/63			
ELECT. DES.	DATE			
MECH. DES.	DATE			
<i>[Signature]</i>	1-26-63			
				SH-113
				3 SHEET

**NOTES**