

DATE: 1-2-51		TMC SPECIFICATION NO. S 616	E
SHEET 1 OF 20			
COMPILED	CHECKED	TITLE: TEST PROCEDURE FOR MODEL GPE-1A	
			

TEST PROCEDURE
FOR THE TECHNICAL MATERIEL CORPORATION
MODEL GPE -1A

DATE 11-4-61
SHEET 2 OF 10

TMC SPECIFICATION NO. S 616

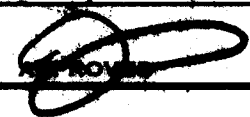

COMPILED

CHECKED

TITLE: TEST PROCEDURE FOR MODEL GPE -1A

APPROVED

TEST EQUIPMENT REQUIRED

1. VTVM Hewlett Packard Model 410B.
2. Counter, Hewlett Packard Model # 524C or equivalent.
3. Scope, Tektronics. Model #514 or equivalent.
4. Signal Generator, Boonton Model 82 or equivalent.
5. Volt Ohmmeter Simpson Model 260.
6. 1 H CR27/U 2,000,000 P; 3,000,000 P; 4,000,000 P.
7. Audio Generator Model # 200C or equivalent.
8. Dummy Load 75 Ω , 2 Watt

DATE 11-4-61
SHEET 3 OF 10

TMC SPECIFICATION NO. S 616

E

COMPILED

CHECKED

TITLE: INSTRUMENT LAYOUT

APPROVED

TEST PROCEDURE FOR MODEL GPE -1A

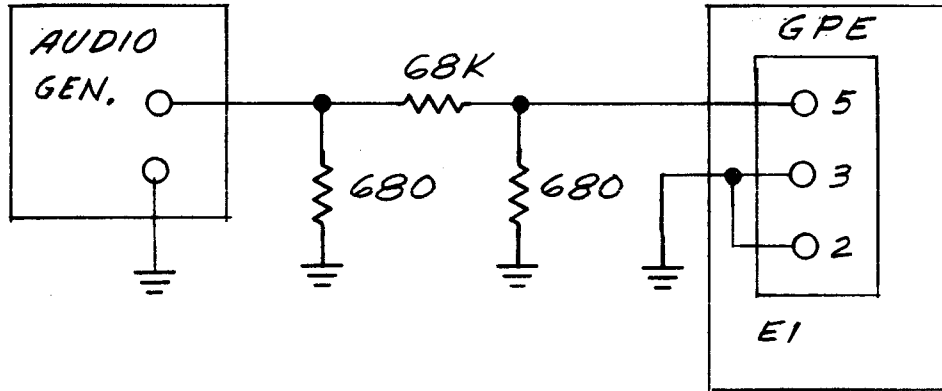

DATE 11-4-61
SHEET 4 OF 10

TMC SPECIFICATION NO. S 616

E

COMPILED

CHECKED

TITLE: TEST PROCEDURE FOR MODEL GPE-1A

APPROVED

TEST INSTRUCTIONS:

- a. Proceed with the test as outlined.
- b. Fill in blanks on report sheet, rejecting those units which do not meet specifications stated herein.
- c. Sign report sheets and submit them to your supervisor.

A. PRELIMINARY

- a. Inspect the unit for obvious mechanical and electrical imperfections.
- b. Inspect all the relative positions of variable capacitors C45 A, B, and C with respect to reference line on the front panel. The capacitors should be in a fully open d position when the pointer of the knob is at the referenc dot below the number 4.
- c. Visually inspect the RF compartments for "shorts" of components to ground as well as between the component parts. Make sure that all RF connections are kept as short as physically possible.
- d. Inspect all the RF wiring of S-2A, B, and C.
- e. Attach jumper between pins 1 and 2 of E1.
- f. Connect 75 ohms 2W load to J4.
- g. Measure the oven resistance to ground;
 - #3-4 0 ohms
 - #1-3 6 ohms
 - #4-5 6 ohms
 - #5-6 6 ohms

DATE 11-4-61
SHEET 5 OF 10

TMC SPECIFICATION NO. S 616

E

COMPILED

CHECKED

TITLE: TEST PROCEDURE FOR MODEL GPE -1A

APPROVED

B. INTERNAL POWER CHECK

- a. Check F-1 and F-2 for correct values as stated in stamping of side plate.
- b. Make sure power switch is in OFF position.
- c. Connect power cable, CA-585 to J1. Output control should be in the fully counterclock-wise position.
- d. Turn POWER "on" and note if all filaments and POWER light work. Line voltage should be 115 volts.
- e. Using the Simpson Model 260 the following measurements should be read at E2:

PIN 1	6.3 VAC
PIN 2	250 VDC
PIN 3	250 VDC
PIN 4	150 VDC
PIN 5	150 VDC
PIN 7	6.3 VAC

C. AMPLIFIER ALIGNMENT

- a. Recheck fully opened capacitor against reference dot.
- b. Set "xtal" switch to "ext".
- c. Connect RF Signal Generator to J3.

DATE 11-4-61
SHEET 8 OF 10

TMC SPECIFICATION NO. S 616

E

COMPILED

CHECKED

TITLE: TEST PROCEDURE FOR MODEL GPE-1A

APPROVED

- d. Set "Emission" to CW.
- e. Set Meter switch to "OUTPUT".
- f. Turn OUTPUT control fully clockwise.
- g. Monitor output voltage with RF voltmeter. (15-20MV input should produce about 3v output, and about -4VU on front panel meter).

a. 2-4MC BAND ALIGNMENT

- a. Set RF bandswitch to 2-4MC band.
- b. Set "tuning" to 2 and generator to 2 MCS with enough voltage for indications. (Refer to C-g).
- c. Tune T7 and T11 for maximum output.
- d. Set "tuning" to 4 and generator to 4 MCS.
- e. Tune C32 and C43 for maximum output.
- f. Repeat steps untill no further adjustments are necessary and then lock slugs.

b. 4-8MC BAND ALIGNMENT

- a. Set RF bandswitch to 4-8MC band.
- b. Set "tuning" to 2 and generator to 4 MCS.
- c. Tune T4, T8, and T12 for maximum output.
- d. Set "tuning" to 4 and generator to 8 MCS.
- e. Tune C22, C31, and C42 for maximum output.
- f. Repeat steps untill no further adjustments are necessary and th n lock slugs.

DATE 11-4-61

SHEET 7 OF 10

TMC SPECIFICATION NO. S 616



COMPILED

CHECKED

TITLE: TEST PROCEDURE FOR MODEL GPE -1A

APPROVED

c. 8-16 BAND ALIGNMENT

- a. Set RF bandswitch to the 8-16 MCS band.
- b. Set "tuning" to 2 and the generator to 8 MCS.
- c. Tune T5, T9, and T13 for maximum output.
- d. Set "tuning" to 4 and generator to 16 MCS.
- e. Tune C21, C30, and C41 to maximum output.
- f. Repeat steps until no further adjustments are necessary.
and then lock slugs.

d. 16-32 BAND ALIGNMENT

- a. Set RF bandswitch to the 16-32 MC band.
- b. Set "tuning" to 2 and the generator to 16 MCS.
- c. Tune T6, T10, and T14 for maximum output.
- d. Set "tuning" to 4 and generator to 32 MCS.
- e. Tune C20, C33, and C44 for maximum output.
- f. Repeat steps until no further adjustments are necessary
and then lock slugs.

D. CRYSTAL ALIGNMENT

- a. Insert 2 MCS crystal into oven position.#1.
- b. Insert 3 MCS crystal into oven position.#2.
- c. Insert 4 MCS crystal into oven position.#3.
- d. Set crystal switch into position #1.
- e. Set up the unit under test for 200 MW output at 2 MCS.
- f. With counter connected to the output adjust C-85 for
2,000,000 \pm 10 cps.

DATE 11-4-61
SHEET 8 OF 30

TMC SPECIFICATION NO. S 616

E

COMPILED

CHECKED

TITLE: TEST PROCEDURE FOR MODEL GPE-1A

APPROVED

- g. Set crystal switch to position #3.
- h. Set up the unit under test for 4 MCS output.
- i. Adjust C-87 for 4,000,000 \pm 20 cps.
- j. Set crystal switch to position #2. Set the unit under test to form 3 MCS output.
- k. Adjust C-3 for 3,000,000 \pm 15 cps.

E. KEYING TEST

Set the unit for 2 mc output at 200 milliwatt. Set up the emission to CW position. Remove jumper on E1,1&2. . Connect the oscilloscope across the load. Key the unit by shorting term 1 to ground and/or J2 to ground and observe the wave form for keying transients. Latter should not be more than 50% of the magnitude of the envelope. Reconnect jumper on E1. .

F. MODULATION

- a. Connect counter to junction of C55-C56. Adjust R32 for 1KC with emission switch to MCW position. Advance the modulation control until approximately 90% modulation is achieved. Observe the modulation envelope on scope connected across load.

NOTE: The scope will show a slight distortion in envelop which approximately is = to 10%.
- b. Set the emission switch to external AM position. Connect signal generator as shown in instrument layout. Set the audio generator at approximately 5V output, and 1000 cycles. Advance the modulation control to 90% modulation. Observe the modulation envelope, distortion must exceed 10%.

DATE 11/2/64		TMC SPECIFICATION NO. S 616	E
SHEET 9 OF 10			
COMPILED	CHECKED	TITLE: TEST PROCEDURE FOR MODEL GPE-1A	
APPROVED			

G. HANDSET

- a. Plug in carbon mike hand set into J-5. Set the emission switch to carbon AM position. Talk into the microphone and adjust the modulation control so that peaks of 100% modulation occur.
- b. Connect ohmeter across terminals 6 and 7. Depress push to talk/5 ohm short circuit on meter; release push-to-talk/open circuit, on meter.
- c. Place a jumper between terminals 8 and 9 at E-1. There must be a 5 ohm short between terminals 6 and 7 or E-1.

DATE 11-13-61
SHEET 10 OF 10

TMC SPECIFICATION NO. S 616

6

COMPILED _____ CHECKED _____

TITLE: PRODUCTION TESTING OF MODEL GPE-1A

APPROVED _____

GPE-1A TEST REPORT SHEET.

ACCEPT

- A. Preliminary
- B. Internal Power ~~Check~~
- C. Amplifier Alignment
 - a. 2-4 MC. Band
 - b. 4-8 MC. Band
 - c. 8-16 MC. Band
 - d. 16-32 MC. Band
- D. Crystal Oven
- E. EI
- F. Modulation
- G. Hand Set

DATE: _____
SERIAL NO: _____
MFG. NO: _____

TESTER _____

