

DATE 1/10/55
SH. 1 OF 1

TMC SPECIFICATION NO. S - 248

COMPILED BY
W.D.C.

TITLE: MOUNTING OF MODIFICATION NAME PLATE (NP-10006)

JOB

APPROVED 

ON REAR OF (FFRD) CHASSIS FRAME FOR R.C.A.F. UNITS

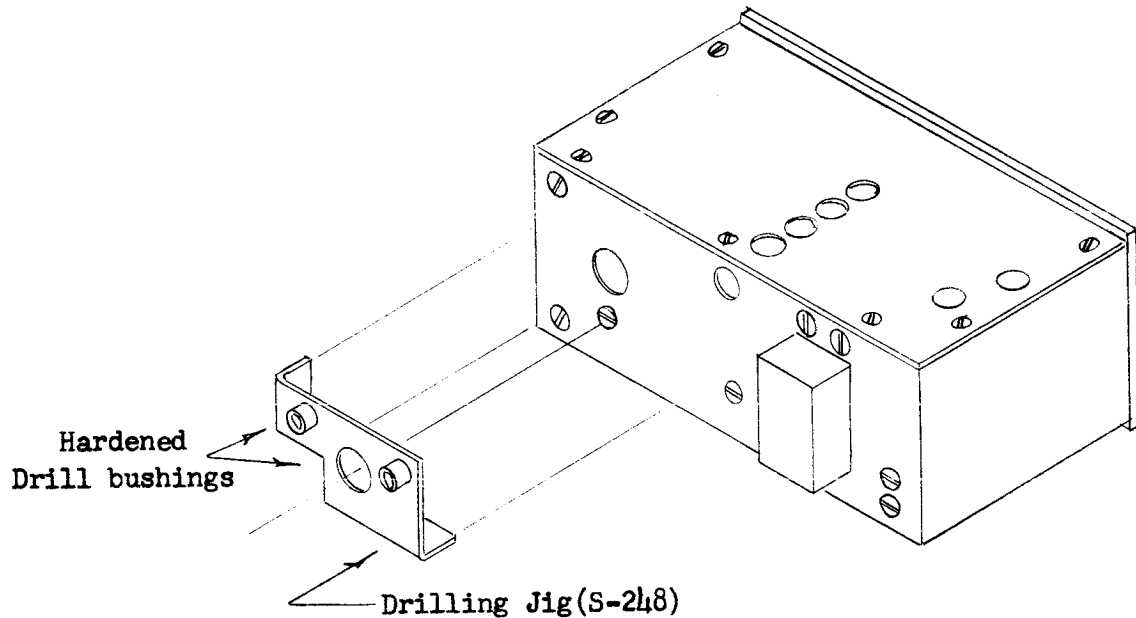

DRILLING PROCEDURE :

1. Place Drilling Jig (S-248) on rear of chassis frame, bottom left hand corner as shown.
2. Drill two holes using #48 drill for 2-56 self tapping screws, thru hardened drill bushings. WARNING: To prevent damage to condenser Do Not drill more than 1/8 beyond inside of chassis.
3. Attach Modification Name Plate (NP-10006) to rear of chassis frame using two 2-56 x 3/16" long self tapping screws (SC-110-1).