

# TMC SPECIFICATION

NO. S 1237

REV:

COMPILED:

CHECKED:

APPD:

SHEET

OF

TITLE:

MODEL DDR-551A  
FINAL TEST PROCEDURE

# TMC SPECIFICATION

NO. S 1237

REV:

COMPILED:

CHECKED:

APPD:

SHEET 1 OF 13

TITLE:

## A. TEST EQUIPMENT REQUIRED

1. Frequency Counter - Hewlett-Packard 524C, 5244L, or equivalent.
2. Signal Generator(s): Two (2) Measurements Corporation Model 82's, or equivalent. Only one (1) required if Sideband EXCITER system with two-tone generator, Model TIG-1, is available.
3. AC VTVM - Ballantine Model 314, or equivalent.
4. Audio Panoramic analyzer for intermodulation distortion test.
5. 30db mixing pad (described in two-tone test).
6. 20db 50 ohm attenuator pad.
7. RF Indicator - Hewlett-Packard Model 410B VTVM, or equivalent.
8. 600 ohm, 1 watt resistor.
9. VOM - Simpson Model 260, or equivalent.

## B. PRELIMINARY

It is assumed that individual units have been tested and installed in the cabinet; that all cables have been connected and all inter-connections have been made.

1. Remove the cover from the line filter located at the rear, left of the cabinet. Connect a three-wire cable as follows:
  - a. WHITE lead to line lug.
  - b. GREEN lead to grounding screw.
  - c. BLACK lead to line lug.
  - \*d. With a Simpson Model 260 VOM, measure the voltage at the front panel convenience outlets; it should be 117V A-C  $\pm 10\%$ .
2. Place switches and controls in the following positions:
  - \*a. HFP-1: STANDBY switch at the rear to STANDBY. The blowers should commence to operate.
  - b. BSP-2: VOLUME controls at mid-position. These may be adjusted at any time for a convenient listening level.
  - c. SBS-11:
    1. AGC RESPONSE selectors - FAST
    2. LEVEL ADJUST controls - mid-position.
    3. DETECTION switches - SSB mode
    4. MONITOR GAIN control - "0"
    5. MANUAL GAIN control - fully ccw.
    6. AGC SELECTOR - Channel A-B
    7. IF BANDWIDTH SELECTOR switches - 7.5KC USB
    8. AFC switch - OFF.
    9. POWER switch: STANDBY

\*RECORD ON TEST DATA SHEET

# TMC SPECIFICATION

NO. S 1237

REV:

COMPILED:

CHECKED:

APPD:

SHEET 2 OF 13

TITLE:

- d. HFS-2: Switch positions are insignificant at this time.
- e. HFR-2:
  - 1. BAND: BAND 1 - 2-3mcs.
  - 2. TUNE-SYNC-OPERATE: SYNC
  - 3. TUNE: Vicinity of 2.0mcs.
  - 4. NOISE SILENCER-OFF-ALIGN SIGNAL switch: OFF.
- f. AFC-3:
  - 1. SENSITIVITY CONTROL: Fully cw.
  - 2. TUNING KCS CONTROL: "0"
  - 3. CARRIER SELECTOR SWITCH: OSC.

## \*C. CHECKOUT PROCEDURE

- \*1. On SBS-11, place POWER switch to ON. On HFP-1, the GREEN standby indicator will go out, and the YELLOW time delay indicator will come on. After time delay, approximately 60 seconds, the YELLOW indicator will go out and the RED operate indicator will come on. At the same time, the NIXIE lights on HFS-2 will indicate, and the tuning dial of HFR-2 will be illuminated.
- \*2. Pull out HFP-1. With a Simpson Model 260 VOM, measure the voltage at test points TP-8001 and TP-8002. It should be +200V. If it is not, adjust the appropriate potentiometer(s), (R-8014 and/or R-8025), and lock the adjustments.

NOTE: For optimum frequency stability, a warm-up of at least 24 hours in the STANDBY condition is recommended.

- \*3. Check of Synthesizer, HFO Circuits and Stability:

This procedure consists of checking the synthesizer and the HFO tracking simultaneously, for all positions of the NIXIE selector switches.

- a. Remove the 47 ohm termination from J-1313 on the HFR-2, and connect a frequency counter to this jack.
- b. Set the NIXIE selectors at 0 2 . 0 0 0 0, and the RF for 2.0mcs. Place the TUNE-SYNC-OPERATE switch to the SYNC position.

\*RECORD ON TEST DATA SHEET

# TMC SPECIFICATION

NO. S 1237

REV:

COMPILED:

CHECKED:

APPD:

SHEET 3 OF 13

TITLE:

- c. Move the TUNE control around 2.0 mcs until the SYNC tone is heard: adjust the TUNE control for zero beat. The SYNC light may chatter during this operation. Place the TUNE-SYNC-OPERATE switch to OPERATE. The SYNC light will come on. The counter should read 3.75 mcs. Return the TUNE-SYNC-OPERATE switch to the SYNC position.
- d. Place the 100 KC NIXIE selector in Position 1. Move the TUNE control until a zero beat is obtained at 2.1 mcs. Place the TUNE-SYNC-OPERATE switch to OPERATE. The counter should read 3.85 mcs. Return the TUNE-SYNC-OPERATE switch to the SYNC position.
- e. Continue this procedure through the remaining positions of the 100 KC selector switch. For each position, move the TUNE control to obtain a zero beat as follows:

<u>100 KC SELECTOR</u>	<u>TUNE CONTROL</u>	<u>FREQ. COUNTER</u>
2	2.2 mcs	3.95 mcs
3	2.3 mcs	4.05 mcs
4	2.4 mcs	4.15 mcs
5	2.5 mcs	4.25 mcs
6	2.6 mcs	4.35 mcs
7	2.7 mcs	4.45 mcs
8	2.8 mcs	4.55 mcs
9	2.9 mcs	4.65 mcs

- f. Place the 10 KC selector switch to Position 1. Move the TUNE control to obtain a zero beat at 2.91 mcs. Place the TUNE-SYNC-OPERATE switch to OPERATE. The counter should read 4.66 mcs. Return the TUNE-SYNC-OPERATE switch to the SYNC position.
- g. Continue this procedure through the remaining positions of the 10 KC selector switch. For each position, move the TUNE control to obtain a zero beat as follows:

<u>100 KC SELECTOR</u>	<u>TUNE CONTROL</u>	<u>FREQ. COUNTER</u>
2	2.92 mcs	4.67 mcs
3	2.93 mcs	4.68 mcs
4	2.94 mcs	4.69 mcs
5	2.95 mcs	4.70 mcs
6	2.96 mcs	4.71 mcs
7	2.97 mcs	4.72 mcs
8	2.98 mcs	4.73 mcs
9	2.99 mcs	4.74 mcs

# TMC SPECIFICATION

NO. S 1237

REV:

COMPILED:

CHECKED:

APPD:

SHEET 4 OF 13

TITLE:

- h. Place the 1 KC selector switch to Position 1. Move the TUNE control until a zero beat is obtained at 2.991 mcs. Place the TUNE-SYNC-OPERATE switch to the OPERATE position. The counter should read 4.741 mcs. Return the TUNE-SYNC-OPERATE switch to the SYNC position.
- i. Continue this procedure through the remaining positions of the 1 KC selector switch. For each position, move the TUNE control to obtain a zero beat as follows:

<u>1 KC SELECTOR</u>	<u>TUNE CONTROL</u>	<u>FREQ. COUNTER</u>
2	2.992 mcs	4.742 mcs
3	2.993 mcs	4.743 mcs
4	2.994 mcs	4.744 mcs
5	2.995 mcs	4.745 mcs
6	2.996 mcs	4.746 mcs
7	2.997 mcs	4.747 mcs
8	2.998 mcs	4.748 mcs
9	2.999 mcs	4.749 mcs

- j. Place the .1 KC selector switch in Position 1. Move the TUNE control until a zero beat is obtained at 2.9991 mcs. Place the TUNE-SYNC-OPERATE switch to the OPERATE position. The counter should read 4.7491 mcs. Return the TUNE-SYNC-OPERATE switch to the SYNC position.
- k. Continue this procedure for the remaining positions of the .1 KC selector switch. For each position, move the TUNE control to obtain a zero beat as follows:

<u>.1 KC SELECTOR</u>	<u>TUNE CONTROL</u>	<u>FREQ. COUNTER</u>
2	2.9992 mcs	4.7492 mcs
3	2.9993 mcs	4.7493 mcs
4	2.9994 mcs	4.7494 mcs
5	2.9995 mcs	4.7495 mcs
6	2.9996 mcs	4.7496 mcs
7	2.9997 mcs	4.7497 mcs
8	2.9998 mcs	4.7498 mcs
9	2.9999 mcs	4.7499 mcs

- l. Place the NIXIE selectors to 0 3 . 0 0 0 0. Move the TUNE control to obtain a zero beat at 3.0 mcs. Place the TUNE-SYNC-OPERATE switch to the OPERATE position. The counter should read 4.75 mcs. Return the TUNE-SYNC-OPERATE switch to the SYNC position.

# TMC SPECIFICATION

NO. S 1237

REV:

COMPILED:

CHECKED:

APPD:

SHEET 5 OF 13

TITLE:

- m. Place the BAND control to BAND 2 (3-4 mc). Move the TUNE control to obtain a zero beat at 3.0 mcs. Place the TUNE-SYNC-OPERATE switch to the OPERATE position. The counter should read 4.75 mcs. Return the TUNE-SYNC-OPERATE switch to the SYNC position.
- n. Continue this procedure for the remaining positions of the MC selector switch, conducting the check at the high and low ends of each band. In each case, the counter should read 1.75 mc above the selected RF frequency when the TUNE-SYNC-OPERATE switch is placed in the OPERATE position.

<u>MC SELECTOR</u>	<u>BAND</u>	<u>TUNE CONTROL</u>	<u>COUNTER</u>
4	2	4 mcs	5.75 mcs
4	3	4 mcs	5.75 mcs
5	3	5 mcs	6.75 mcs
6	3	6 mcs	7.75 mcs
6	4	6 mcs	7.75 mcs
7	4	7 mcs	8.75 mcs
8	4	8 mcs	9.75 mcs
8	5	8 mcs	9.75 mcs
9	5	9 mcs	10.75 mcs
10	5	10 mcs	11.75 mcs
11	5	11 mcs	12.75 mcs
12	5	12 mcs	13.75 mcs
12	6	12 mcs	13.75 mcs
13	6	13 mcs	14.75 mcs
14	6	14 mcs	15.75 mcs
15	6	15 mcs	16.75 mcs
16	6	16 mcs	17.75 mcs
16	7	16 mcs	17.75 mcs
17	7	17 mcs	18.75 mcs
18	7	18 mcs	19.75 mcs
19	7	19 mcs	20.75 mcs
20	7	20 mcs	21.75 mcs
21	7	21 mcs	22.75 mcs
22	7	22 mcs	23.75 mcs
23	7	23 mcs	24.75 mcs
24	7	24 mcs	25.75 mcs
24	8	24 mcs	25.75 mcs
25	8	25 mcs	26.75 mcs
26	8	26 mcs	27.75 mcs
27	8	27 mcs	28.75 mcs
28	8	28 mcs	29.75 mcs
29	8	29 mcs	30.75 mcs
30	8	30 mcs	31.75 mcs
31	8	31 mcs	32.75 mcs

# TMC SPECIFICATION

NO. S 1237

REV:

COMPILED:

CHECKED:

APPD:

SHEET 6 OF 13

TITLE:

- \*o. Place the NIXIE selector at 15 . 0 0 0 0: the BAND control to BAND 6 (12-16 mcs), and the TUNE control at 15 mcs. With the TUNE-SYNC-OPERATE switch, at SYNC, obtain a zero beat. Place the TUNE-SYNC-OPERATE switch to OPERATE. Carefully move the TUNE control in both directions checking for symmetrical swing of the SYNCHRONIZE meter from 0 to either side. The swing must extend on either side of the center to the first index, and the SYNC indicator must remain lit during this operation. If this condition should not be achieved, adjust R3442 on the 3400 check of the HFS-2.
- p. Remove the counter from J1313. Replace the 47 ohm termination.

#### 4. Check of the AFC-3 Unit

- a. Place the AFC ON OFF switch on SBS-11 to ON.
- b. Place the NOISE SILENCER switch on RCVR to ALIGNMENT SIGNAL.
- \*c. Depress and hold down the RESET button on AFC-3. Adjust the TUNING KCS control for maximum indication on the CARRIER LEVEL meter, and zero center scale on the DRIFT meter. The CARRIER LEVEL meter should read approximately in the center of the GREEN. Release the RESET button.
- \*d. Check the FADE and DRIFT ALARM lamps. They should be extinguished. The DRIFT METER should remain at zero center scale.
- \*e. Place the CARRIER SELECTOR switch to RCC. There should be no change in indications.
- \*f. Place the NOISE SILENCER switch on HFR-1 to OFF. The CARRIER LEVEL meter should fall, and the FADE alarm should light. Return the NOISE SILENCER switch to ALIGNMENT SIGNAL position. Move the SENSITIVITY control fully CCW. The FADE indicator should light and the CARRIER LEVEL meter should fall. Return the SENSITIVITY control fully CW.
- g. Return the CARRIER SELECTOR switch to OSC.
- h. Place the AFC ON OFF switch on SBS-11 to OFF.

#### 5. Check of Model SBS-11 - Sideband Converter:

- a. Pull out the SBS-11 drawer. Lock in position and remove top cover.
- \*b. Note the markings on the input filters on the IF strips at the right. The markings on the filters should read, from front to back,:

- |    |        |        |     |
|----|--------|--------|-----|
| 1. | FX-173 | 7.5 KC | LSB |
| 2. | FX-169 | 3.5 KC | LSB |
| 3. | FX-168 | 3.5 KC | USB |
| 4. | FX-172 | 7.5 KC | USB |

(unless otherwise designated by customer).

\*RECORD ON TEST DATA SHEET

# TMC SPECIFICATION

NO. S 1237

REV:

COMPILED:

CHECKED:

APPD:

SHEET 7 OF 13

TITLE:

- c. Connect a signal generator at 1,746,500  $\pm$ 500 cycles J6800. This represents an USB input from the RF unit, approximately 3500 cyc. from the carrier. Use the counter to set the signal generator. Set the signal generator for 1 mv (1000 uv) output.
- \*d. On the 7.5KC USB strip, remove the plug from J1029, and insert a 50 ohm dummy load. Measure the voltage across the load. It should be .5V RMS or 1.4V peak-to-peak. Adjust R-116 on 7.5 KC USB strip, if required, to obtain this condition. Remove dummy load and replace plug in J102.
- \*e. Set the signal generator to 1,748,500 cyc.  $\pm$ 200 cycles, with 1 mv output. Set the IF BANDWIDTH selectors to 3.5 KC USB. Remove plug from J102 on 3.5 KC USB strip, and insert 50 ohm dummy load. The voltage across the load should be .5V RMS. Adjust R-116, if necessary, to obtain this result. Remove dummy load and reconnect plug to J102.
- \*f. Set the signal generator to 1,751,500 cyc.  $\pm$ 200 cycles with .1 mv output. Set the IF BANDWIDTH selectors to 3.5 KC LSB. Remove the plug from J102 on the 3.5 KC LSB strip, and insert 50 ohm dummy load. Voltage across the load should be .5V RMS. Adjust R116, if necessary, to obtain this result. Remove dummy load and reconnect plug to J102.
- \*g. Set the signal generator to 1,753,500 cyc  $\pm$ 500 cycles with 1 mv output. Set the IF BANDWIDTH selectors to 7.5KC LSB. Remove the plug from J102 on the 7.5 KC LSB strip, and insert a 50 ohm dummy load. The voltage across the load should be .5V RMS. Adjust R116, if necessary, to obtain this condition. Remove dummy load and reconnect plug to J102.
- \*h. Check of AM Function and MANUAL GAIN Control -
1. Set the signal generator to 1.75 mcs, modulated with 1 KC at 30%. Set signal generator output at 1 mv.
  2. On SBS-11, set DETECTION switch to AM. Set channel A IF BANDWIDTH selector to 3.5 KC USB, and Channel B IF BANDWIDTH selector to 3.5 KC LSB position.
  3. A 1 KC tone should be heard in each monitor.
  4. Place AGC SELECTOR switch to MANUAL. With MANUAL GAIN control fully CCW, no audio should be heard. As this control is moved clockwise, audio output should increase.
  5. Set MANUAL GAIN control fully CCW. Set AGC SELECTOR to CH. A.

\*RECORD ON TEST DATA SHEET



# TMC SPECIFICATION

NO. S 1237

REV:

COMPILED:

CHECKED:

APPD:

SHEET 8

OF 13

TITLE:

## \*6. Sensitivity and Dynamic AGC Characteristic Check -

- a. Set controls on HFR-2 as follows:
  1. BAND - BAND #1 - 2-3mc
  2. TUNE - 2.5 mcs.
- b. Set NIXIE selector on HFS-1 to 0 2 . 5 0 0 0.
- c. Set IF BANDWIDTH selector on SBS-11 to 7.5 KC USB position.
- d. Synchronize the RF head at 2.5 mcs. Lock the TUNE control.
- e. Place the DETECTION switches on SBS-11 to SSB.
- f. Connect a signal generator via a 20 db pad to J1001 on the HFR-2. Set the frequency to 2.5015 mcs, UNMODULATED, and the output to 100 uv. A 1.5 KC tone should be heard.

NOTE: Because of the 20 db pad, the actual input to J1001 on the HFR-1 is 10 uv; that is, actual input = sig. gen. output ÷ 10.

- g. Reduce the output of the signal generator to zero. The RF LEVEL meter should fall to zero.
- h. Slowly and carefully increase the signal generator output, noting the RF LEVEL meter on the HFR-2. Note the signal generator output the instant the RF LEVEL meter deflects from zero. Divide the reading by ten. The result is receiver sensitivity. It should be 1 uv or less.
- i. Increase the signal generator output to 100,000 uv. Set CH. A LINE LEVEL adjust for a reading of 0 VU. Decrease signal generator output to 10 uv. The LINE LEVEL indication should not fall below -3 VU.
- j. Repeat the sensitivity and AGC check at the center of the remaining 7 bands, off setting the signal generator about 1.5 KC above the synthesizer frequency.

## \*7. Signal PLUS Noise/Noise Check -

- a. Tune the RF unit to 2.5 mcs. Set the NIXIE selectors to 2.5000 mcs. Synchronize the system.
- b. Set the Channel A and B IF BANDWIDTH selectors to 7.5 KC USB.
- c. Set the DETECTION switches to SSB.
- d. Slide out the SBS-11 drawer.
- e. Connect a signal generator at 2.5 mcs, via a 20 db pad, to J1001 of HFR-2. Set the signal generator output to 10 uv, and tune slightly above 2.5 mcs to produce approximately 50 cycle audible tone. Connect a Ballantine Model 314 VTVM to terminals 2 and 4 of TB-9001 (audio output box mounted on side of RAK) and 600 ohm resistor to terminals 7 and 9. Set Ballantine range to 100V full scale.

\*RECORD ON TEST DATA SHEET

# TMC SPECIFICATION

NO. S 1237

REV:

COMPILED:

CHECKED:

APPD:

SHEET 9 OF 13

TITLE:

- f. Set the AGC SELECTOR to MANUAL. Adjust the MANUAL GAIN control fully cw.
- g. Adjust the Channel A LINE LEVEL ADJUST for 0 VU indication on the Channel A line level meter. The Ballantine meter should read approximately 24V. Note: The DB indication on the Ballantine.
- h. Remove the signal generator output connection. The Ballantine indication should drop by at least 15 db.
- i. Repeat the Signal-Plus-Noise-To-Noise check at 14mc and 28mc.

## \*8. Two-Tone Test

- a. Set up the test equipment as shown below. As an alternate method, a sideband generator system with Model CBE Sideband Exciter, may be used in place of the two signal generators.

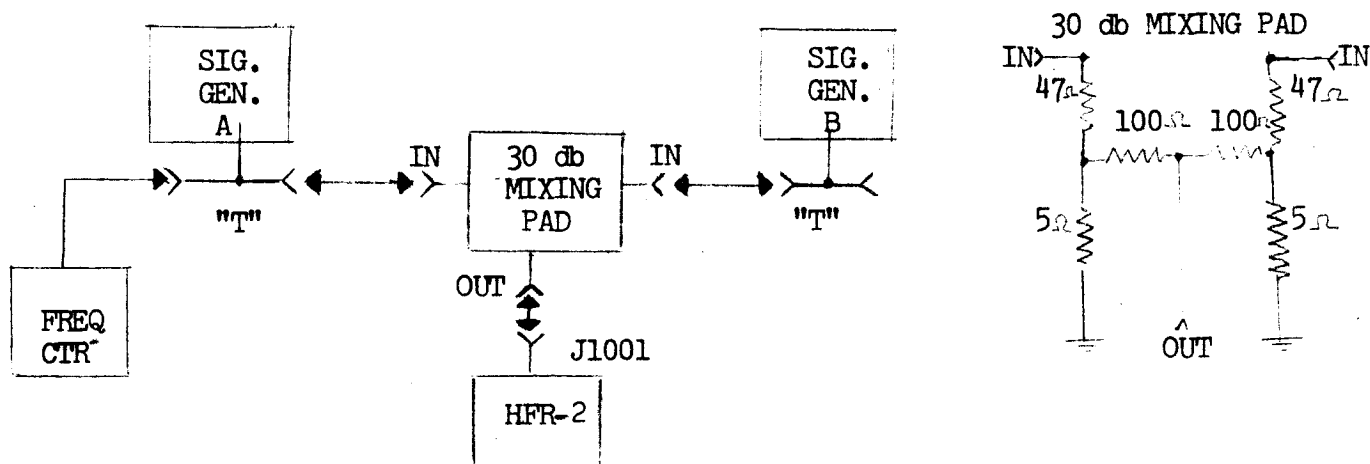

- b. Set signal generator "A" to 2.501 mcs, .3 volts output.
- c. Connect the frequency counter to the "T" at signal generator "B". Adjust signal generator "B" for .3 volts output at 2.501575 mcs.
- d. Adjust controls, selectors and switches on the HFS-2 and HFR-2 to synthesize the receiver at 2.5 mcs. When the system is synchronized, place the TUNE-SYNC-OPERATE switch to OPERATE.
- e. Place the Channel B IF BANDWIDTH selector to the 3.5KC USB position.
- f. Connect audio analyzer between pins 12 and 14 of TB-9001, set controls as follows:
  1. POWER switch ON.
  2. VERT. CALIB. SELECTOR to DB.
  3. SWEEP RANGE SELECTOR to 20KC log.
  4. SCALE SELECTOR to 0.5
  5. INPUT MULT. to XL K.
  6. INPUT POT. -Set the control so that the top of the two tones is on the 20db line of the screen. The total distortion products should be 40db down. Record on Test Data Sheet

\*RECORD ON TEST DATA SHEET

# TMC SPECIFICATION

NO. S 1237

REV:

COMPILED:

CHECKED:

APPD:

SHEET 10 OF 13

TITLE:

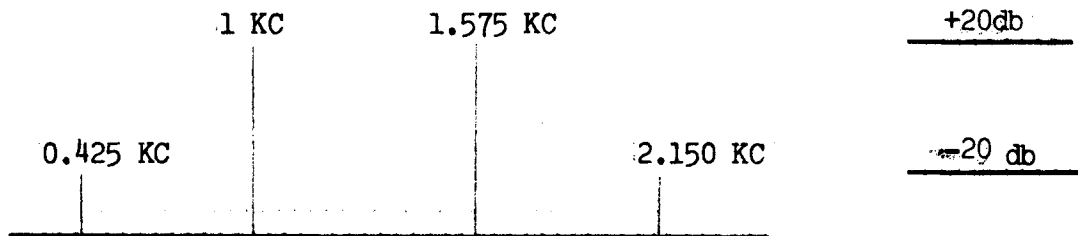

## \*9. Ant. Box Assembly -

- a. Connect antenna to connector on rear terminal box.
- b. Tune in WWV on the receiver.
- c. Adjust for Channel A operation and switch off Channel B.
- d. Set Channel A, LINE LEVEL ADJUST, to 0 VU on meter.
- e. Connect AC VTVM to terminals strip marked REC. 1, CHAN. A. The meter will indicate the signal received.
- f. Switch Channel A off. Adjust for Channel B operation and set LINE LEVEL ADJUST to 0 VU on meter.
- g. Move AC VTVM to CHAN. B terminals. The meter will indicate the signal received. Remove antenna; the signal will drop in amplitude.

\*RECORD ON TEST DATA SHEET

# TMC SPECIFICATION

NO. S 1237

REV:

COMPILED:

CHECKED:

APPD:

SHEET 11 OF 13

TITLE:

THE TECHNICAL MATERIEL CORPORATION

MAMARONECK, N.Y.

DDR-551B TEST DATA SHEET #1

SERIAL NO.: \_\_\_\_\_

MFG. NO.: \_\_\_\_\_

B-1d	Line voltage at convenience outlets is 117 VAC $\pm 10\%$	_____ VOLTS
B-2a	Blowers operate	_____ OK
C-1	Standby, Time delay and operate indicators function, with proper timing sequence.	_____ OK
C-2	Voltage at TP-8001 and TP-8002 is exactly 200 volts.	_____ OK
C-3	Synthesizer, HFO and Stability check	_____ OK
C-3a	Symmetrical swing of SYNC meter	_____ OK
C-4c	CARRIER LEVEL and DRIFT meters	_____ OK
C-4d	FADE and DRIFT ALARM; DRIFT meter	_____ OK
C-4e	CARRIER SELECTOR to RCC - no change	_____ OK
C-4f	FADE and CARRIER	_____ OK
C-5b	IF strips properly installed	_____ OK
C-5d-g	.5 volt $\pm 10\%$ reading obtained on USB and LSB strips; R-116 on USB and LSB strips locked.	_____ OK
C-5h	AM Function and MANUAL GAIN control	_____ OK

# TMC SPECIFICATION

NO. S 1237

REV:

COMPILED:

CHECKED:

APPD:

SHEET 12 OF 13

TITLE:

## DDR-551B TEST DATA SHEET #2

C-6	Sensitivity 2.5 mcs (1 uv or better)	_____ uv
	AGC check 2.5 mcs (3 db or less)	_____ db
	Sensitivity 3.5 mcs (1 uv or better)	_____ uv
	AGC check 3.5 mcs (3 db or less)	_____ db
	Sensitivity 5 mcs (1 uv or better)	_____ uv
	AGC check 5 mcs (3 db or less)	_____ db
	Sensitivity 7 mcs (1 uv or better)	_____ uv
	AGC check 7 mcs (3 db or less)	_____ db
	Sensitivity 10 mcs (1 uv or better)	_____ uv
	AGC check 10 mcs (3 db or less)	_____ db
	Sensitivity 14 mcs (1 uv or better)	_____ uv
	AGC check 14 mcs (3 db or less)	_____ db
	Sensitivity 20 mcs (1 uv or better)	_____ uv
	AGC check 20 mcs (3 db or less)	_____ db
	Sensitivity 28 mcs (1 uv or better)	_____ uv
	AGC check 28 mcs (3 db or less)	_____ db
C-7	Signal plus noise/noise 2.5 mcs (15db or better)	_____ db
	Signal plus noise/noise 14 mcs (15db or better)	_____ db
	Signal plus noise/noise 28 mcs (15db or better)	_____ db
C-8	Two Tone Test 2.5 mcs (record level of 3rd order products)	_____ db
	Two Tone Test 14 mcs (40 db down or better)	_____ db
	Two Tone Test 28 mcs (40 db down or better)	_____ db
C-9	ANT. BOX ASSEMBLY	_____ OK

# TMC SPECIFICATION

NO. S 1237

REV:

COMPILED:

CHECKED:

APPD:

SHEET 13 OF 13

TITLE:

## DDR-551B TEST DATA SHEET #3

The manufacturing and serial numbers of the units contained in this cabinet are listed below:

	MFG. #	SERIAL #
HFR-2	_____	_____
HFS-2	_____	_____
SBS-11	_____	_____
BSP-2	_____	_____
HFP-1	_____	_____

DATE: \_\_\_\_\_

TESTER: \_\_\_\_\_

