

RR-111

THE TECHNICAL MATERIEL CORPORATION
MAMARONECK, NEW YORK

Property of:
THE TECHNICAL MATERIEL CORPORATION
MAMARONECK, NEW YORK

THIS DRAWING IS THE PROPERTY OF THE TECHNICAL MATERIEL CORPORATION AND IS LOANED TO THE USER FOR HIS INFORMATION ONLY. IT IS NOT TO BE REPRODUCED OR USED IN ANY MANNER WITHOUT THE WRITTEN PERMISSION OF THE TECHNICAL MATERIEL CORPORATION.

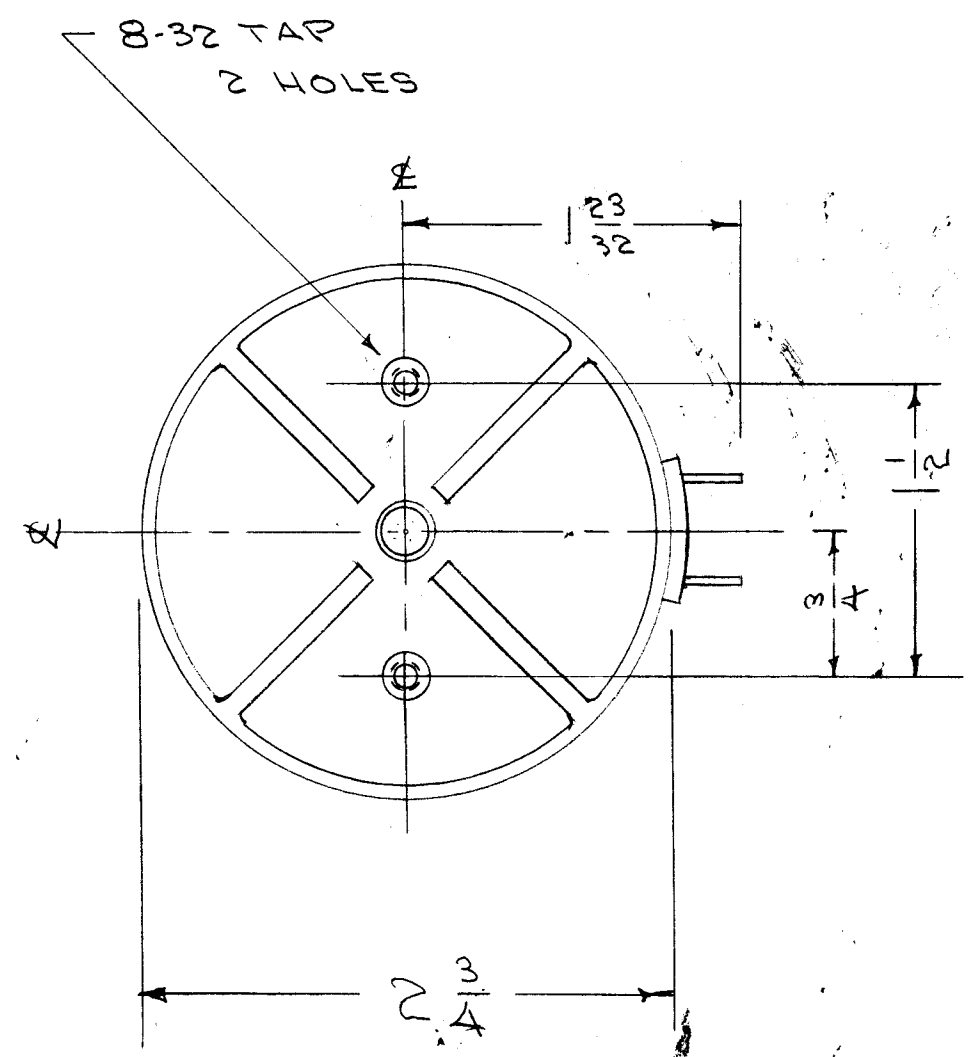

TERMINAL IMPEDANCE - 600/600
 ATTENUATION - 20 STEPS, 2 db per STEP
 TAPERED ON LAST STEP TO CUT-OFF
 (INFINITY.)
 NO DETENTS
 CONTACT SPACING - 15° BETWEEN CENTERS.
 ° ROTATION - 300°
 CONTINUOUS RATING - 0.6 WATTS
 PEAK AUDIO RATING - 2.5 WATTS

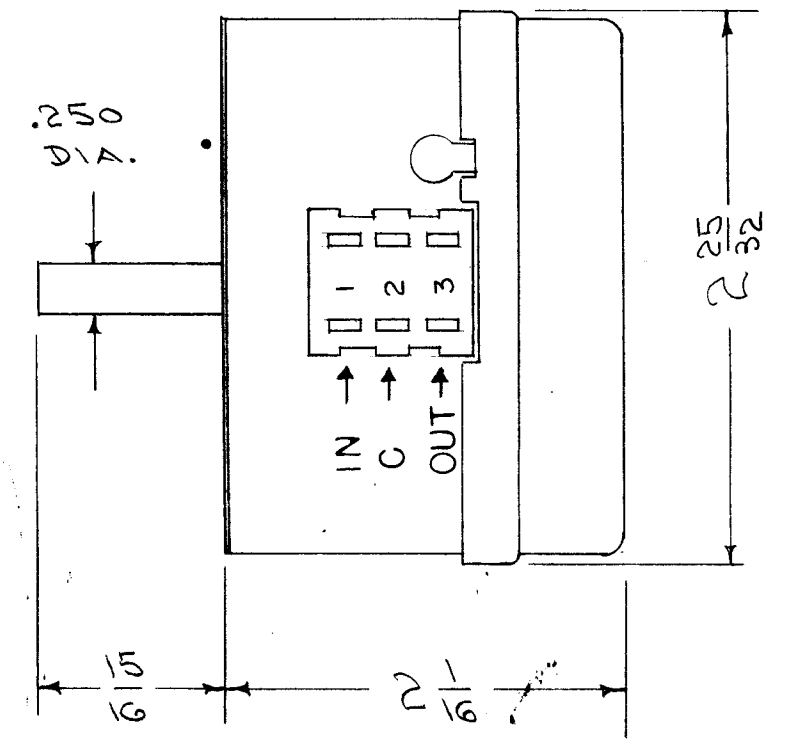

DIMENSIONS FOR REF. ONLY

REF. THE DAVEN CO. TYPE T-321-G

ISSUE	ITEM	CHANGED FROM	DATE	CH. NO.	DRAFTS	CHECKER	ENG. APP.
TOLERANCES			SCALE:				
DEC. DIM. ±			MAXIMUM ALLOWABLE TOLERANCES HAVE BEEN DETERMINED AND ANY DEVIATIONS WILL BE CAUSE FOR REJECTION.				
FRAC. DIM. ±			REMOVE ALL BURRS AND SHARP EDGES				
ANGULAR DIM. ±							

1	RSA-2			10-31-56
REQ. PER UNIT	MODEL	PROJECT NO.	ASS'Y. NO.	DATE
USED ON				

REQ. ITEM	PART NO.	DESCRIPTION	SYMBOL
		THE TECHNICAL MATERIEL CORP. MAMARONECK, NEW YORK	
STOCK SIZE		ATTENUATOR, "T" TYPE	
MATERIAL			
		10/31/56	AJJ.
TYPE & TEMPER	HEAT TREAT. SPEC.	DRAWN	CHECKED
		P.L.K.	RR-111
FINISH & SPEC. NO.		ELEC. DES. APP.	MECH. DES. APP.