

STANDARD DRAWING

RIVET DIA.	HOLE SIZE & DRILL No.	5052 ALUMINUM RIVET 7178 ALUMINUM MANDREL										MONEL RIVET ZINC PLATED 1050 STEEL MANDREL ZINC PLATED									
		D	H	h	W	L	G	GRIP RANGE	RIVET CODE No. E	TYP. ULT. STRENGTH SHEAR	TYP. ULT. STRENGTH TENSILE	D	H	h	W	L	G	GRIP RANGE	RIVET CODE No. E	TYP. ULT. STRENGTH SHEAR	TYP. ULT. STRENGTH TENSILE
3/32	.096-.100 #41	.094	.188	.024	.057	.212	.020-.125	32													
7/64	.113-.117 #33														.190	.020-.070	319				
						.170	.020-.062	41							.190	.020-.070	419				
						.232	.063-.125	42							.240	.071-.120	424				
						.294	.126-.187	43							.290	.121-.170	429	420	630		
						.419	.251-.312	44	150	217	.125	.236	.025	.076	.350	.171-.230	435				
						.481	.313-.375	46							.400	.231-.280	440				
						.254	.020-.125	52							.190	.020-.050	519				
						.379	.126-.250	54							.240	.051-.100	524				
						.504	.251-.375	56	235	330	.156	.263	.028	.090	.300	.101-.160	530				
						.629	.376-.500	58							.370	.161-.230	537	560	840		
						.277	.020-.125	62							.240	.020-.090	624				
						.402	.126-.250	64							.300	.091-.150	630				
						.527	.251-.375	66							.360	.151-.200	636				
						.652	.376-.500	68	320	450	.187	.320	.040	.114	.390	.201-.230	639	940	1410		
						.777	.501-.625	610							.500	.231-.340	650				
															.650	.341-.490	665				
															.750	.491-.590	675				
1/4	.257-.261 F														.500	.151-.300	850				
															.700	.301-.500	870	1600	2400		

REVISIONS					
SYM	DESCRIPTION	DATE	E.M.N. NO.	DRAFT	CHKD
Ø	ORIGINAL RELEASE FOR PRODUCTION	2/27/67	Ø	CV.	

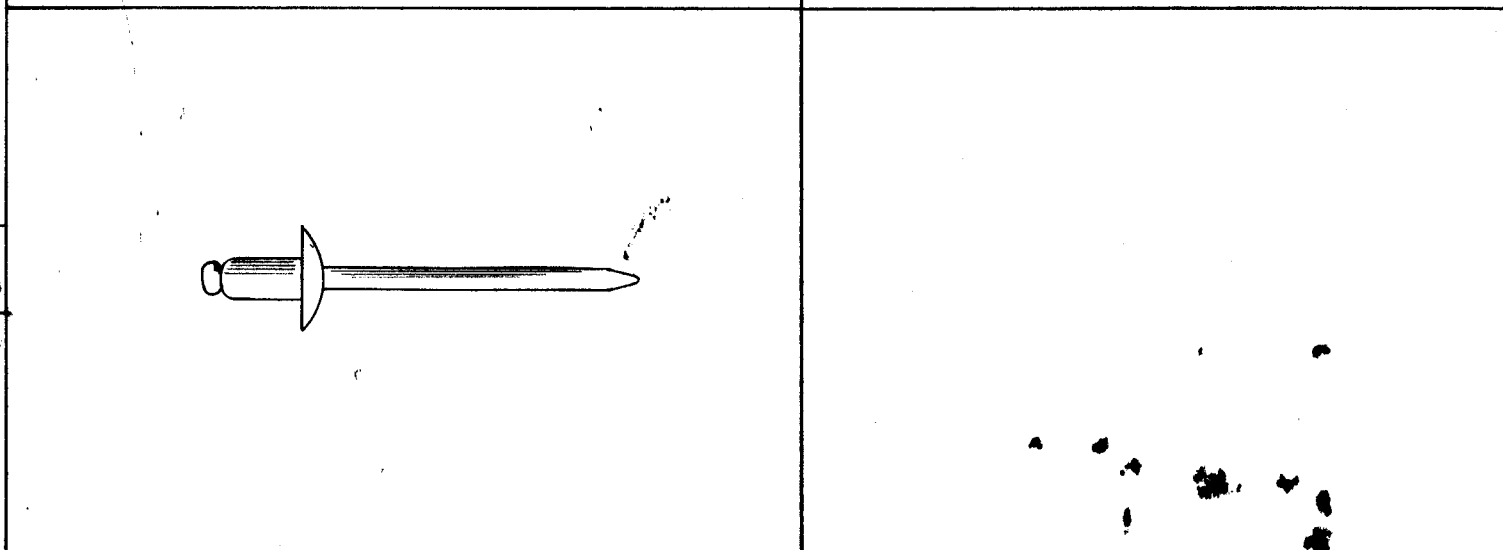
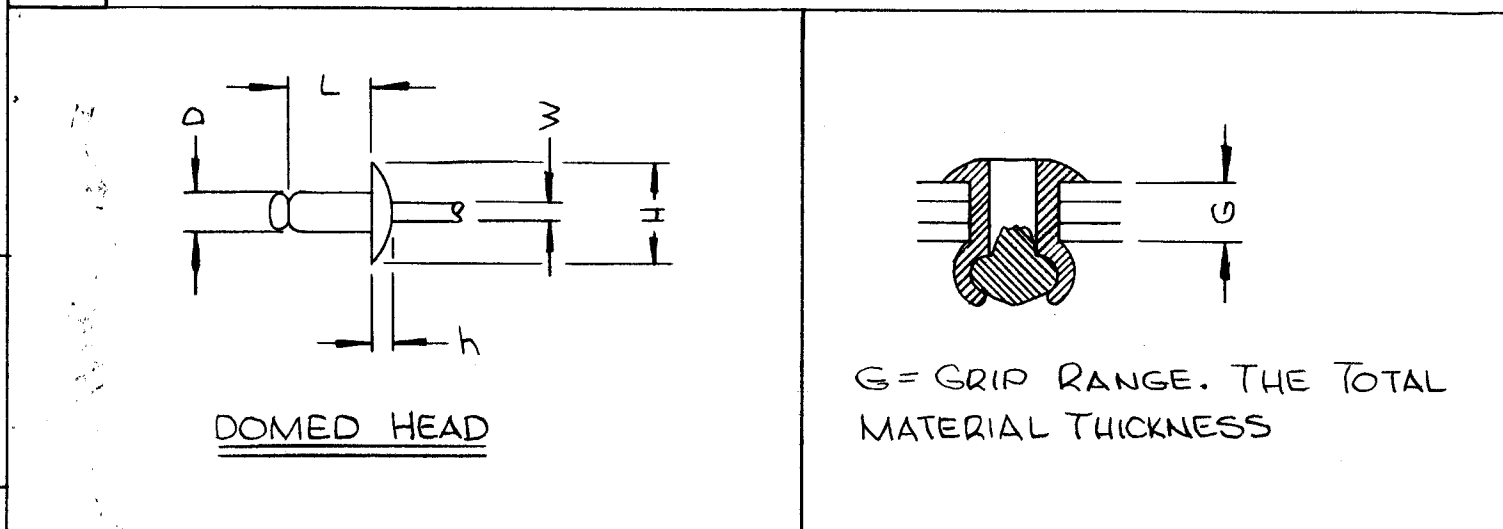

NOTE: USE TMC TOOL (TP142) FOR INSTALLATION OF RIVETS

TMC PART No. SHALL BE IN THE FOLLOWING FORM

RI100 094-32

BASIC TMC P/N RIVET DIA (COL "D") RIVET CODE No (SEE CHART\*)

REQ'D.	ITEM	PART NUMBER	DESCRIPTION	SYMBOL
LIST OF MATERIAL				
MATERIAL			THE TECHNICAL MATERIEL CORP. MAMARONECK, NEW YORK	
SEE NOTES				
FINISH			TITLE	
SEE NOTES			RIVET, BLIND, EXPANSIVE	
UNLESS OTHERWISE SPECIFIED DIMENSIONS ARE IN INCHES AND INCLUDE CHEMICALLY APPLIED OR PLATED FINISHES			DRAWN <i>WJG</i> CHECKED <i>QCB</i> ELECT. DES. <i>WJG</i> MECH. DES. <i>WJG</i>	DATE 11.3.66 DATE DATE DATE 2-3-67
DECIMALS .X ± .05 .XX ± .01 .XXX ± .005			FRACTIONS ± 1/64 ANGLES ± 0° 30'	FINAL APPROV. <i>WJG</i> DATE 2/27/67 SHEET REV. LTR.

Q'TY./UNIT	MODEL USED ON	ASS'Y. NO.
	CODE	S401-443

NOTES

THE CONTENTS OF THIS DRAWING ARE THE EXCLUSIVE PROPERTY OF THE TECHNICAL MATERIEL CORP. ITS UNAUTHORIZED USE OR REPRODUCTION IN WHOLE OR IN PART IS STRICTLY FORBIDDEN.