

IF IT IS FOUND DESIRABLE TO CHANGE ANY TOLERANCE OR OTHER DETAIL SPECIFIED ON THIS DRAWING NOTIFY THE PURCHASER PROMPTLY.

MAXIMUM ALLOWABLE TOLERANCES HAVE BEEN DETERMINED AND DEVIATIONS WILL BE CAUSE FOR REJECTION. REMOVE ALL BURRS AND SHARP EDGES

TOLERANCE -  $\pm 10\%$   
TAPER - LINEAR } ONLY AVAILABLE "A"

RA-100 E

RESISTANCE VALUES AVAILABLE AS STANDARD	
1	400
2	500
4	750
6	1000
10	2000
15	3000
20	5,000
25	7,500
30	10,000
40	15,000
50	20,000
60	25,000
75	30,000
100	40,000
200	50,000
300	

LETTER DES.	SHAFT LENGTH		LENGTH OF FLAT
	ROUND OR FLATTED	SLOTTED	
A		5/8	
C		3/4	
D	7/8	7/8	.375 $\pm .010$
E	1	1	.500 "
G	1 1/4	1 1/4	.625 "
H	1 1/2	1 1/2	.625 "
J	2	2	.625 "
K	2 1/2	2 1/2	2.125 "
L	1 3/4	1 3/4	.625 "

SWITCH	
A	NO SWITCH
B	SPSTSW
C	DPSTSW

SHAFT STYLE	
F	FLATTED
R	ROUND
S	SLOTTED
X	LOCKING (SLOTTED)

TEMP. COEF.		
S	STANDARD	160 PPM
Q	SPECIAL	20 PPM

TYPE DESIGNATION TO BE IN FOLLOWING FORM

RA-100 A S F D 103 A

COMPONENT SWITCH TEMP. COEF. SHAFT STYLE SHAFT LENGTH RES. TOL. & TAPER

STANDARD DRAWING

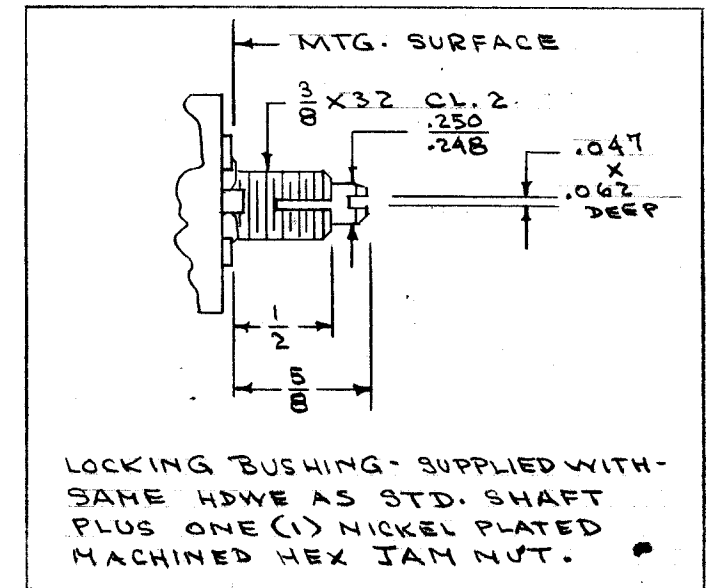
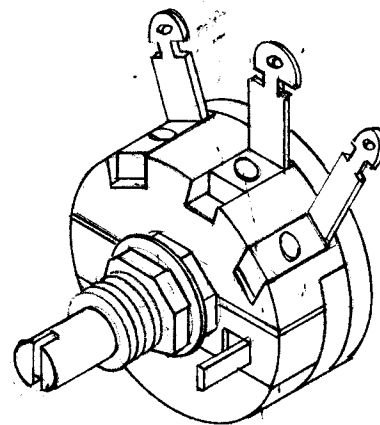
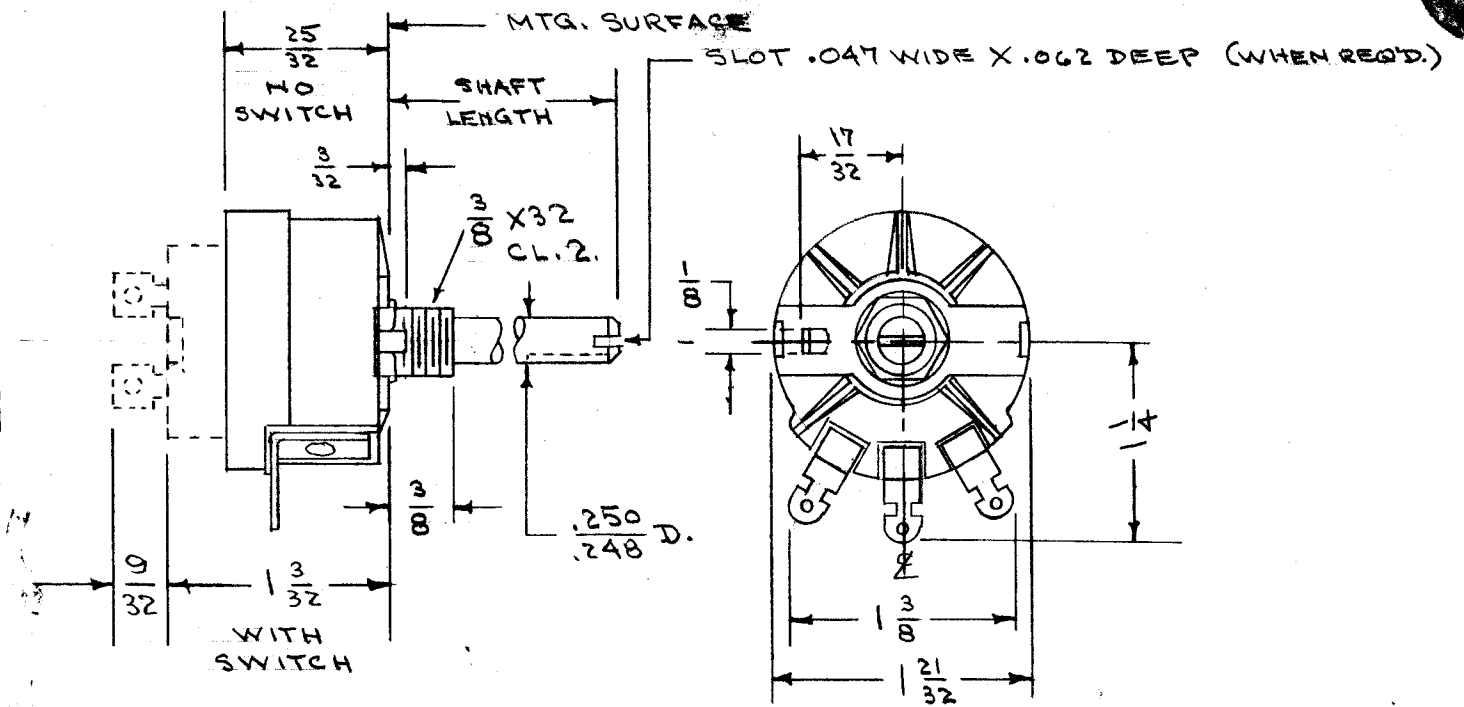

LOCKING BUSHING - SUPPLIED WITH SAME HDWE AS STD. SHAFT PLUS ONE (1) NICKEL PLATED MACHINED HEX JAM NUT.

POWER RATING	WATTS
LINEAR RESIST. CONTROL	3
TAPERED CONTROL	2

REF: CLAROSTAT MFG. CO. SERIES 5B

NOTE: STANDARD SHAFT UNITS ARE SUPPLIED WITH ONE (1) NICKEL PLATED MACHINE HEX. MTG. NUT AND ONE (1) INTERNAL TOOTH LOCKWASHER.

REQ.	ITEM	PART NO.	DESCRIPTION	SYMBOL
			THE TECHNICAL MATERIEL CORP. MAMARONECK. NEW YORK	
			RESISTOR, ADJUSTABLE	
			W. W. 3 WATT	
			TYPE & TEMPER	CDR-10-654 KZ WDE
			HEAT TREAT. SPEC.	DRAWN: JAIDe ELEC. DES. APP. MECH. DES. APP. A. J. J.
			FINISH & SPEC. NO.	RA-100 E

ISSUE	ITEM	CHANGED FROM	DATE	CN. NO.	DRAFTS	CHECKER	ENG. APP.
E	1	SHAFT LENGTH L" ADDED	12/15/57	5	P.B.	JAIDe	WDE
D	2	WAS 4 WATTS	11/1/57	4	JAIDe	WDE	WDE
C	1	COMPLETE REVISION	10/6/54	3	E.D.D.	JAIDe	WDE

ALL OTHERS	DEC. DIM. $\pm$ FRAC. DIM. $\pm$ ANGULAR DIM. $\pm$	SCALE:	DRILL, PUNCH, COMMERCIAL STOCK SIZES AND MANUFACTURERS TOLERANCES ARE NOT INCLUDED.	Per. UNIT	MODEL	PROJECT NO.	ASSY. NO.	DATE	USED ON
------------	-----------------------------------------------------------	--------	-------------------------------------------------------------------------------------	-----------	-------	-------------	-----------	------	---------