

REQ. PER UNIT	USED ON			PX 875	Ø
	MODEL	ASS'Y. NO.	DATE		
1	RTMU-1	A4052	12-12-64		

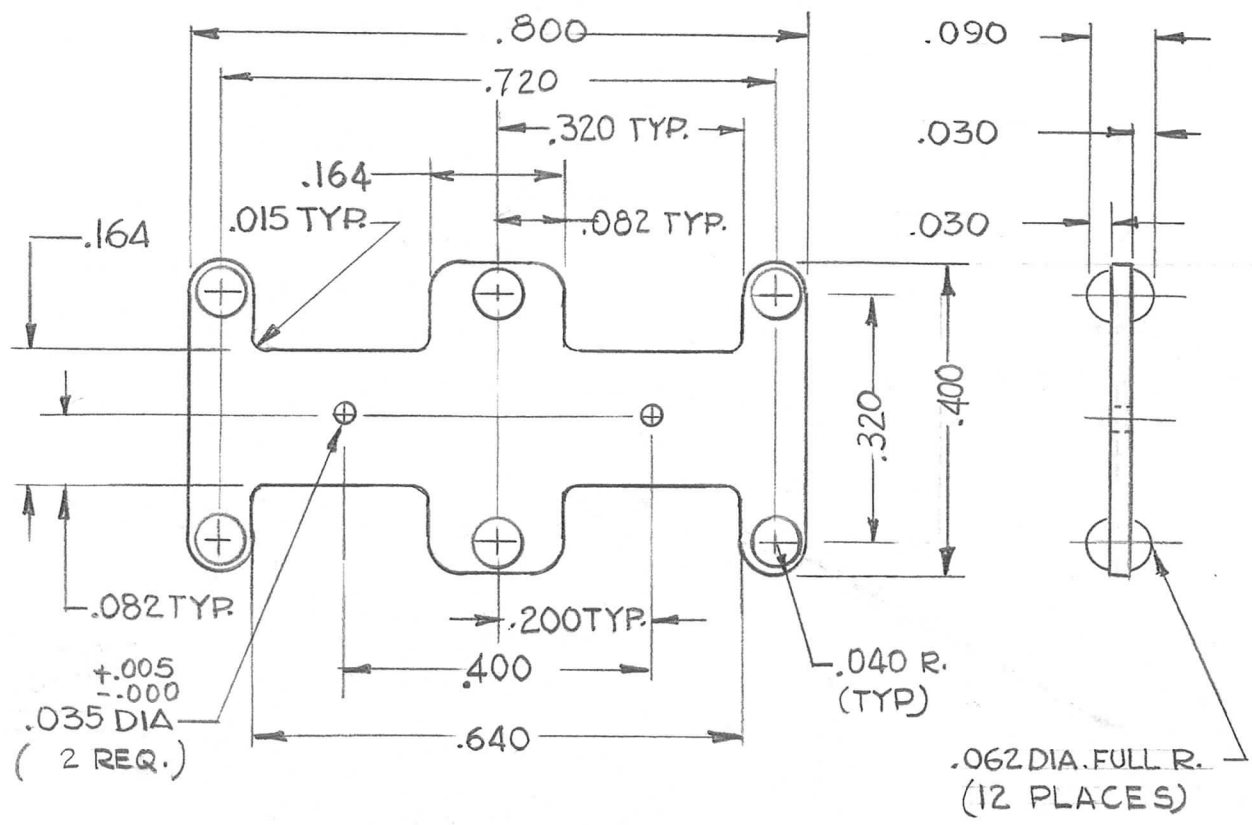

PX 875-2
(MFG. RC-RP800090-1A)

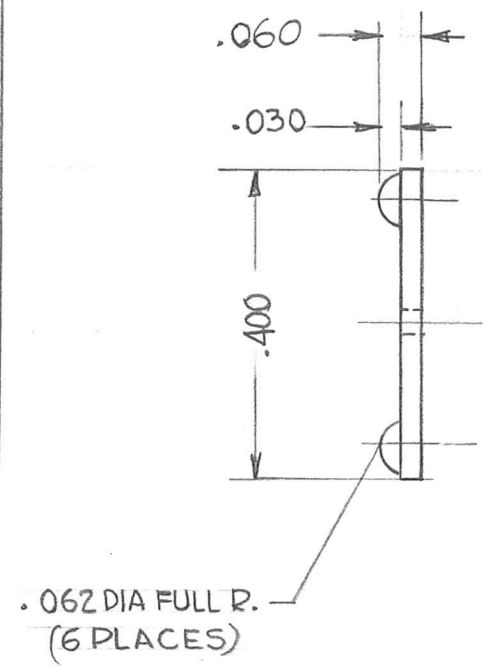

PX 875-1
(SAME FRONT VIEW AS PX 875-2)
(MFG. RGRP 800060-2A)

REQ.	ITEM	PART NO.	EATON	DESCRIPTION	SYMBOL	
				THE TECHNICAL MATERIEL CORP. MAMARONECK. NEW YORK		
Ø	ORIGINAL RELEASE FOR PRODUCTION	2.865	Ø	RFI		
X	EXPER. RELEASE	12-14-64		G.D.L. J.M.		
SYM	DESCRIPTION	DATE	CH. NO.	DRAFTS	CHECKER	ENG. APP.
UNLESS OTHERWISE SPECIFIED DIMENSIONS ARE IN INCHES AND INCLUDE CHEMICALLY APPLIED OR PLATED FINISHES		SCALE DO NOT SCALE				
DECIMALS .X ± .05 .XX ± .01 .XXX ± .005	TOLERANCES	FRACTIONS ± 1/64 ANGLES ± 0° 30'	CODE C	5401-354		
		TYPE & TEMPER		HEAT TREAT. SPEC.		
		FINISH & SPEC. NO.		ELEC. DES. APP.	MECH. DES. APP.	
		G.D.L. 12-14-64		W. JORDAN 2/8/65	W. JORDAN 2/8/65	PX 875 Ø