

| REQ. PER UNIT | USED ON | | |
|---------------|---------------|------------|--------|
| | MODEL | ASS'Y. NO. | DATE |
| 4 | TER-25K/600B | | 9-9-63 |
| 4 | TER-18K/600BF | | 9-9-63 |

PX-776 | Ø

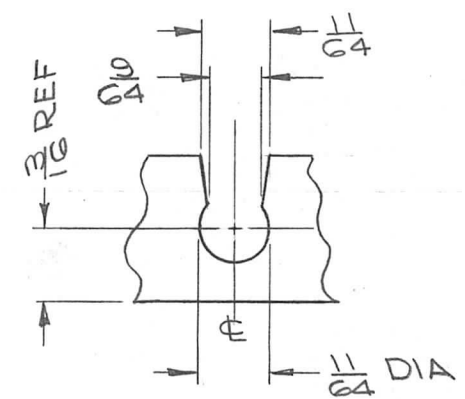
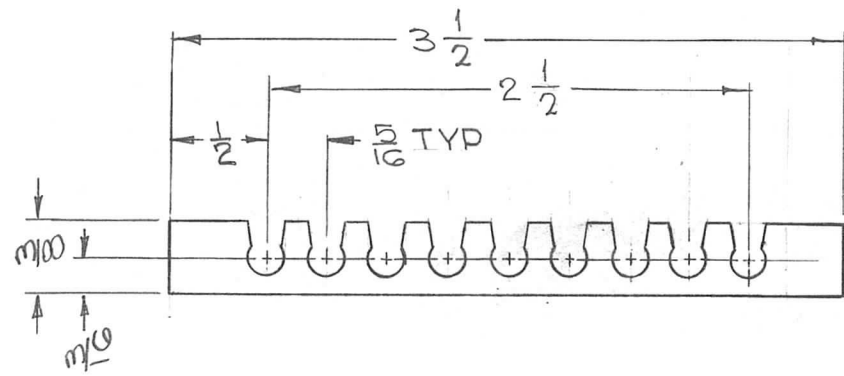

~ CUTOUT DETAIL - 9 REQ ~

| | | | | | | | REQ. ITEM | PART NO. | F. BUDETTI | DESCRIPTION | SYMBOL |
|---|---------------------------------|-----------|---------|--------|---------|---------------|--------------------|-------------------|------------------------------|-----------------|----------------|
| | | | | | | | 1/4 THK | | THE TECHNICAL MATERIEL CORP. | | |
| | | | | | | | STOCK SIZE | | MAMARONECK, NEW YORK | | |
| Ø | ORIGINAL RELEASE FOR PRODUCTION | 4/2/65 | AA | SRG | | | TEFLON | | SPACER, COIL | | |
| X1 | TER 18K/600BF WAS TER 15K/600BF | 1-13-64 | | SRG | | | | | | | |
| SYM | DESCRIPTION | DATE | CH. NO. | DRAFTS | CHECKER | ENG. APP. | MATERIAL | | | | |
| UNLESS OTHERWISE SPECIFIED DIMENSIONS ARE IN INCHES AND INCLUDE CHEMICALLY APPLIED OR PLATED FINISHES | | | | | | SCALE | | | | | |
| | | | | | | 1:1 | | | | | |
| DECIMALS | | FRACTIONS | | CODE | | TYPE & TEMPER | | HEAT TREAT. SPEC. | DRAWN | CHECKED | FINAL APPROVAL |
| .X ± .05 | | ± 1/64 | | | | | | | | | |
| .XX ± .01 | | ANGLES | | | | | | | | | |
| .XXX ± .005 | | ± 0° 30' | | | | | | | | | |
| | | | | | | | FINISH & SPEC. NO. | | ELEC. DES. APP. | MECH. DES. APP. | PX-776 Ø |