

PX-605 B

| TMC PART NO. | "A" QUAN. REQ. | "B"     | "C"  | USED ON |
|--------------|----------------|---------|------|---------|
| PX-605-1     | 10             | 4 3/16  | .359 | CL-266  |
| PX-605-2     | 9              | 3 13/16 | .359 | CL-266  |
| PX-605-3     | 10             | 5 1/2   | 1/2  | CL-267  |
| PX-605-4     | 9              | 5       | 1/2  | CL-267  |

NOTICE TO PERSONS RECEIVING THIS DRAWING

THE TECHNICAL MATERIEL CORPORATION claims proprietary right in the material disclosed hereon. This drawing is issued in confidence for engineering information only and may not be reproduced or used to manufacture anything shown hereon without permission from THE TECHNICAL MATERIEL CORPORATION to the user. This drawing is loaned for mutual assistance and is subject to recall at any time.

Property of:  
THE TECHNICAL MATERIEL CORPORATION  
MAMARONECK, NEW YORK

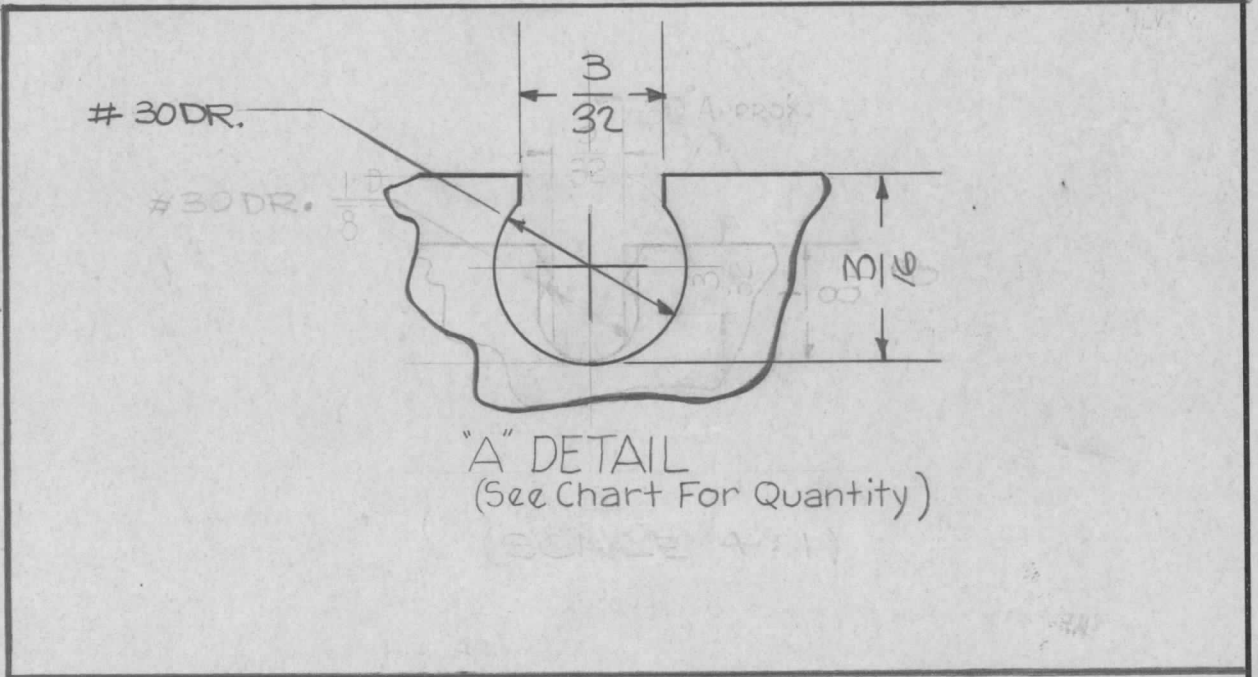
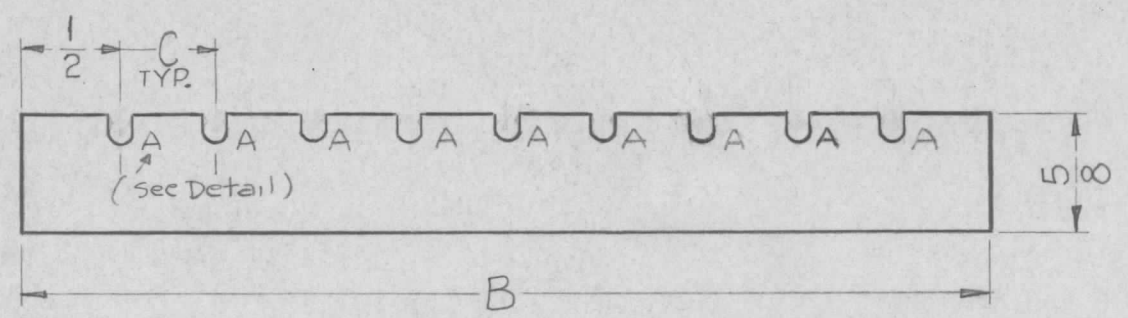

| SYM | DESCRIPTION                     | DATE    | CH. NO. | DRAFTS      | CHECKER     | ENG. APP.   |
|-----|---------------------------------|---------|---------|-------------|-------------|-------------|
| B   | DIM. 3/16 WAS 1/8. ("A" DETAIL) | 11/76   | 15215   | H.V.V.      | J.C.B.      | [Signature] |
| A   | "A" DETAIL COMPLETELY REVISED   | 6/19/65 | 14203   | [Signature] | [Signature] | [Signature] |

UNLESS OTHERWISE SPECIFIED:  
DIMENSIONS ARE IN INCHES  
TOLERANCES ON FRACTIONS ± 1/64 DECIMALS ± .005 ANGLES ± 1/2°

SCALE:  
MAXIMUM ALLOWABLE TOLERANCES HAVE BEEN DETERMINED AND ANY DEVIATIONS WILL BE CAUSE FOR REJECTION. REMOVE ALL BURRS AND SHARP EDGES

|               |              |         |            |        |
|---------------|--------------|---------|------------|--------|
| REQ. PER UNIT | MODEL        | SECTION | ASS'Y. NO. | DATE   |
|               | TER-3500-300 |         |            | 2-6-61 |

| REQ. ITEM     | PART NO.            | DESCRIPTION   | SYMBOL                          |                   |       |         |                |  |  |             |             |    |  |
|---------------|---------------------|---|---------------------------------|-------------------|-------|---------|----------------|--|--|-------------|-------------|----|--|
|               | 1/8" THK STOCK SIZE | THE TECHNICAL MATERIEL CORP. MAMARONECK, NEW YORK   |                                 |                   |       |         |                |  |  |             |             |    |  |
|               | TEFLON MATERIAL     | SPACER, COIL  |                                 |                   |       |         |                |  |  |             |             |    |  |
|               |                     | <table border="1"> <tr> <td>TYPE &amp; TEMPER</td> <td>HEAT TREAT. SPEC.</td> <td>DRAWN</td> <td>CHECKER</td> <td>FINAL APPROVAL</td> </tr> <tr> <td></td> <td></td> <td>[Signature]</td> <td>[Signature]</td> <td>2B</td> </tr> </table> | TYPE & TEMPER                   | HEAT TREAT. SPEC. | DRAWN | CHECKER | FINAL APPROVAL |  |  | [Signature] | [Signature] | 2B |  |
| TYPE & TEMPER | HEAT TREAT. SPEC.   | DRAWN   | CHECKER                         | FINAL APPROVAL    |       |         |                |  |  |             |             |    |  |
|               |                     | [Signature]   | [Signature]                     | 2B                |       |         |                |  |  |             |             |    |  |
|               |                     | FINISH & SPEC. NO.  | ELEC. DES. APP. MECH. DES. APP. | PX-605 B          |       |         |                |  |  |             |             |    |  |