

REQ. PER. UNIT	USED ON			PX-525	C
	MODEL	ASS'Y. NO.	DATE		
1	GPT-40K	AT-101	2-19-60		

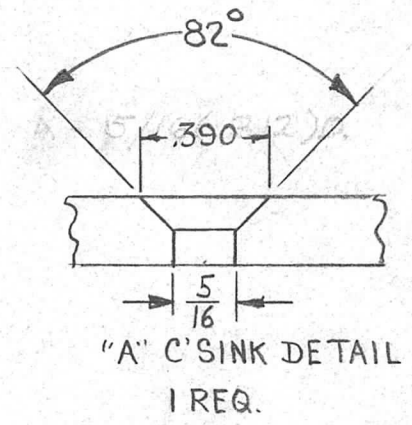
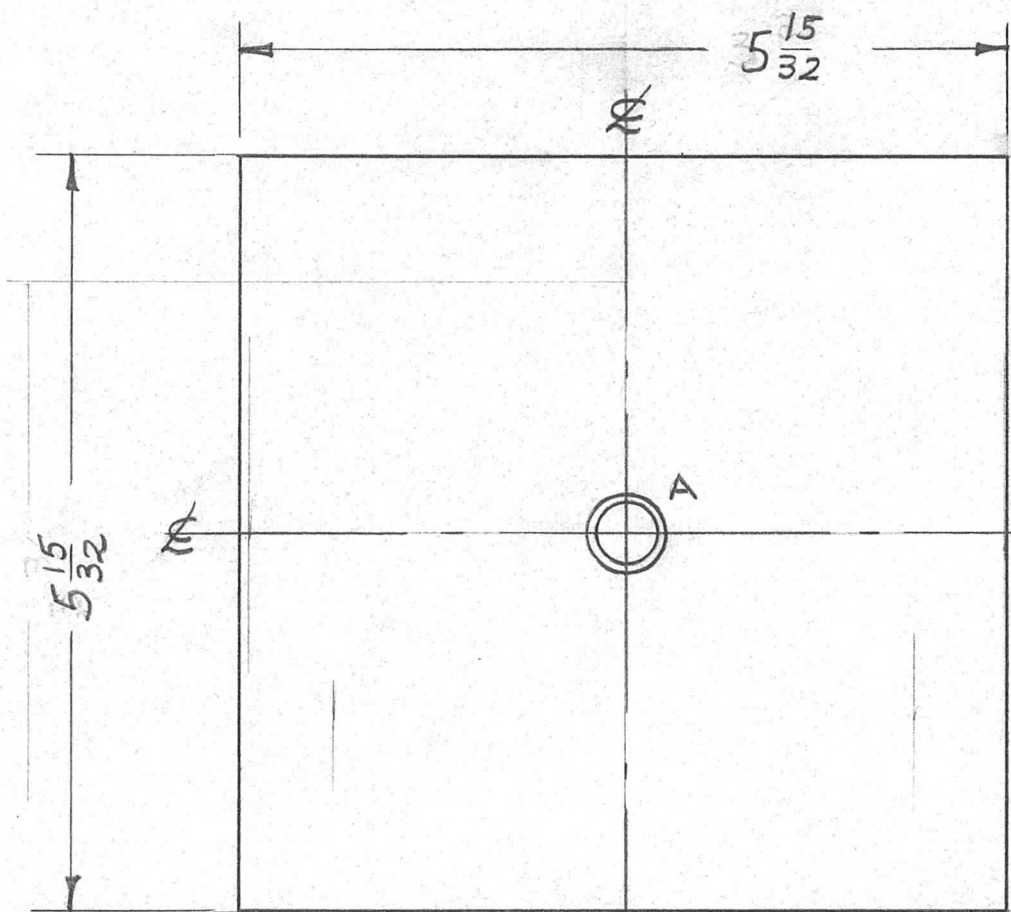

ISSUE	ITEM	CHANGED FROM	DATE	CH. NO.	DRAFTS	CHECKER	ENG. APP.	REQ. ITEM	PART NO.	DESCRIPTION	SYMBOL		
C	1	ON DETAIL "A" 82° ADD.	10.21.64	12684	lrb	JCS	[Signature]			THE TECHNICAL MATERIEL CORP. MAMARONECK, NEW YORK PLATE CONTACT BUTTON FEED THRU	C		
B	2	MAT. WAS EPOXY						1/4 TH'K.					
B	1	5 15/32 WAS 3 31/32	4-4-60	1972	ms	JLD		STOCK SIZE					
A	2	C'SINK DETAIL ADDED						SILICONE GLASS					
A	1	"A" WAS 5/16 D.	3-11-60		ms	VO	[Signature]						
TOLERANCES			SCALE:			MATERIAL		G7		DRAWN			
DEC. DIM. ±			MAXIMUM ALLOWABLE TOLERANCES HAVE BEEN DETERMINED AND ANY DEVIATIONS WILL BE CAUSE FOR REJECTION. REMOVE ALL BURRS AND SHARP EDGES			TYPE & TEMPER		HEAT TREAT. SPEC.		CHECKED			
FRAC. DIM. ±						FINISH & SPEC. NO.		ELEC. DES. APP		MECH. DES. APP		FINAL APPROVAL	
ANGULAR DIM. ±												[Signature] [Signature] PX-525	