

REQ. PER. UNIT	USED ON			PX-516	A
	MODEL	ASS'Y. NO.	DATE		
1	GPT-40K	AX-209	2-12-60		

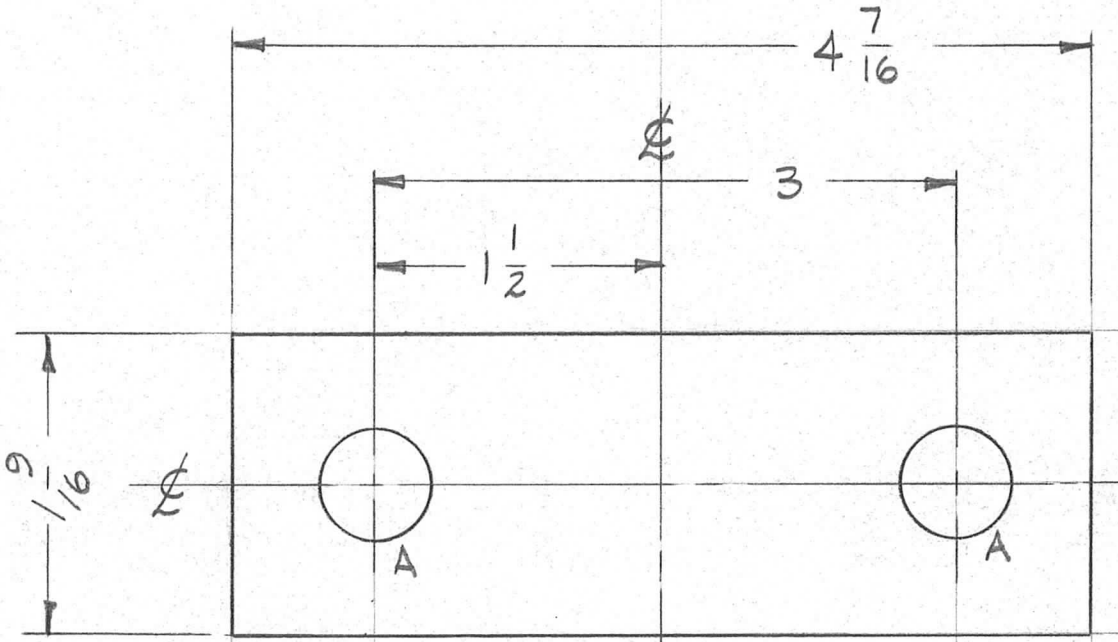

A - 9/16 (.562) DIA. 2 REQ'D.

								REQ. ITEM	PART NO.	DESCRIPTION	SYMBOL		
								1/4 THICK		THE TECHNICAL MATERIEL CORP.			
								STOCK SIZE		MAMARONECK, NEW YORK			
								SILICONE GLASS		SUB PLATE, FEED THRU			
								MATERIAL		PA - SECTION			
A	1	MAT. WAS EPOXY	3-28-60	1951	918	ma	16	G7	TORILLO JDe	DOB			
ISSUE	ITEM	CHANGED FROM	DATE	CH. NO.	DRAFTS	CHECKER	ENG. APP.	TYPE & TEMPER	HEAT TREAT. SPEC.	DRAWN	CHECKED	FINAL APPROVAL	
TOLERANCES			SCALE: #										
DEC. DIM. ±			MAXIMUM ALLOWABLE TOLERANCES HAVE BEEN DETERMINED AND ANY DEVIATIONS WILL BE CAUSE FOR REJECTION. REMOVE ALL BURRS AND SHARP EDGES										
FRAC. DIM. ± 1/64													
ANGULAR DIM. ±													
								FINISH & SPEC. NO.		ELEC. DES. APP		MECH. DES. APP	
										PX-516		A	