

PX-504D

HOLES  
A ~ 13/64 (.203) DIA.  
B ~ 1/16 DIA.

REQ.  
11  
2

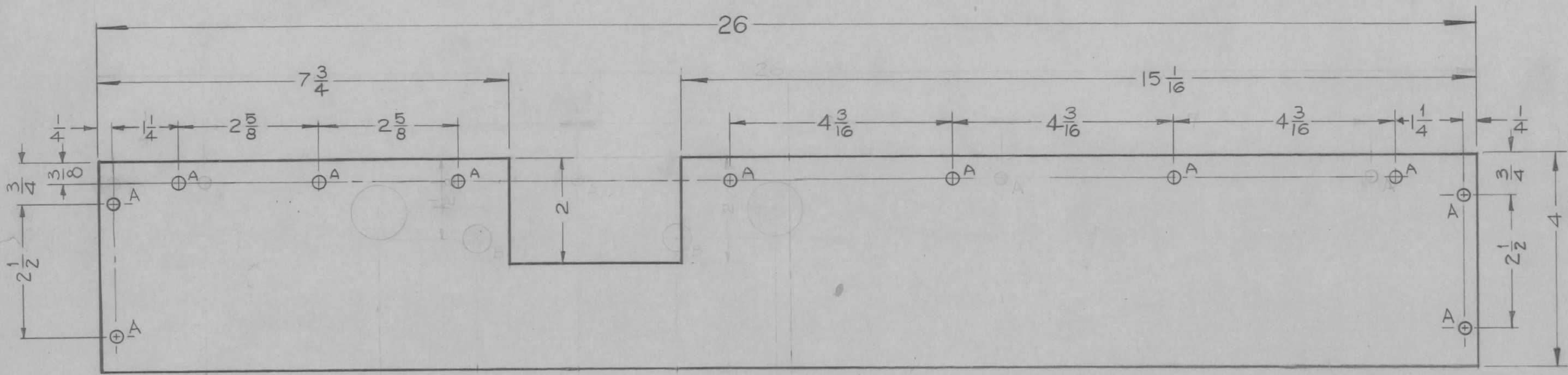

LD-979 2-28 Mc  
LD-872 (2) for Spare Parts only

REF ~ TMC DWG NO. LD-791 (2) for Spare Parts Only

D	2	for Spare Parts Only Note Added to LD-791 (2)	1/28/60	3602	DM	JCB	QB
	1	LD-872 REF ADDED					
C	3	2" X 3-3/16 CUTOUT	6	25	Cy	file	QB
	2	(3) "A" HOLES ADDED	24	32			
	1	(2) "B" HOLES DELETED	60				
B		ADD TWO "B" HOLES	4-4-60	1993	Cy	file	QB
A	2	QUAN WAS 2 PER UNIT	3-29-60	1961	MG	file	QB
	1	MAT WAS EPOXY					

ISSUE	ITEM	CHANGED FROM	DATE	CH. NO.	DRAFTS	CHECKER	ENG. APP.
TOLERANCES			SCALE: 1/2" = 1"				
DEC. DIM. ±			MAXIMUM ALLOWABLE TOLERANCES HAVE BEEN DETERMINED AND ANY DEVIATIONS WILL BE CAUSE FOR REJECTION.				
FRAC. DIM. ± 1/64			REMOVE ALL BURRS AND SHARP EDGES				
ANGULAR DIM. ±							

1	AX-209	GPT-40K	1-23-60
REQ. PER UNIT	MODEL	PROJECT NO.	DATE
		ASS'Y. NO.	
USED ON			

REQ. ITEM	PART NO.	DESCRIPTION	SYMBOL
	1/4" THK.	THE TECHNICAL MATERIEL CORP.	
	STOCK SIZE	MAMARONECK. NEW YORK	
	SILICONE GLASS	SUPPORT, CAPACITOR	
	MATERIAL	FRONT	
G7		DR M... LA... QB	
TYPE & TEMPER	HEAT TREAT. SPEC.	DRAWN	CHECKED
		QB	Y... QB
FINISH & SPEC. NO.		ELEC. DES. APP.	MECH. DES. APP.
			PX-504 D