

REQ. PER. UNIT	USED ON			PX-481
	MODEL	ASS'Y. NO.	DATE	
1	ATSTU-2		6-11-59	

A - $\frac{9}{64}$ (.140) 4 - REQ'D
 B - $\frac{1}{2}$ (.500) D - 1 "

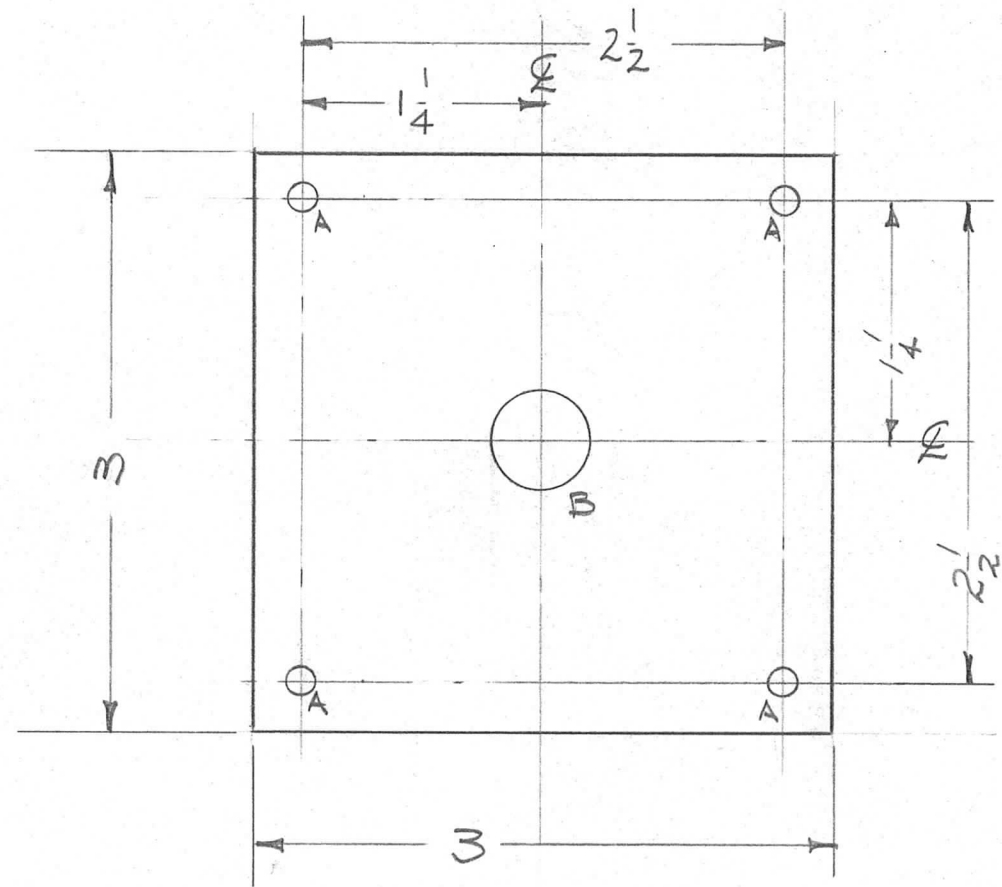

ISSUE	ITEM	CHANGED FROM	DATE	CH. NO.	DRAFTS	CHECKER	ENG. APP.	REQ. ITEM	PART NO.	DESCRIPTION	SYMBOL				
								$\frac{1}{4}$		THE TECHNICAL MATERIEL CORP.					
								STOCK SIZE		MAMARONECK, NEW YORK					
								TEFLON		PLATE MTG. OUTPUT TERMINAL					
								MATERIAL		ATS-50(70) TU2					
TOLERANCES			SCALE:							<i>10/11/59</i>	<i>file</i>	<i>APB</i>			
DEC. DIM. \pm			MAXIMUM ALLOWABLE TOLERANCES HAVE BEEN DETERMINED AND ANY DEVIATIONS WILL BE CAUSE FOR REJECTION. REMOVE ALL BURRS AND SHARP EDGES					TYPE & TEMPER	HEAT TREAT. SPEC.	DRAWN	CHECKED	FINAL APPROVAL			
FRAC. DIM. $\pm \frac{1}{64}$															
ANGULAR DIM. \pm															
								FINISH & SPEC. NO.		ELEC. DES. APP.	MECH. DES. APP.	PX-481			