

REQ. PER. UNIT	USED ON			PX-479	A
	MODEL	ASS'Y. NO.	DATE		
2	AX-120		9-9-59		

B- #36 DRILL - 120° APART 3 REQ.

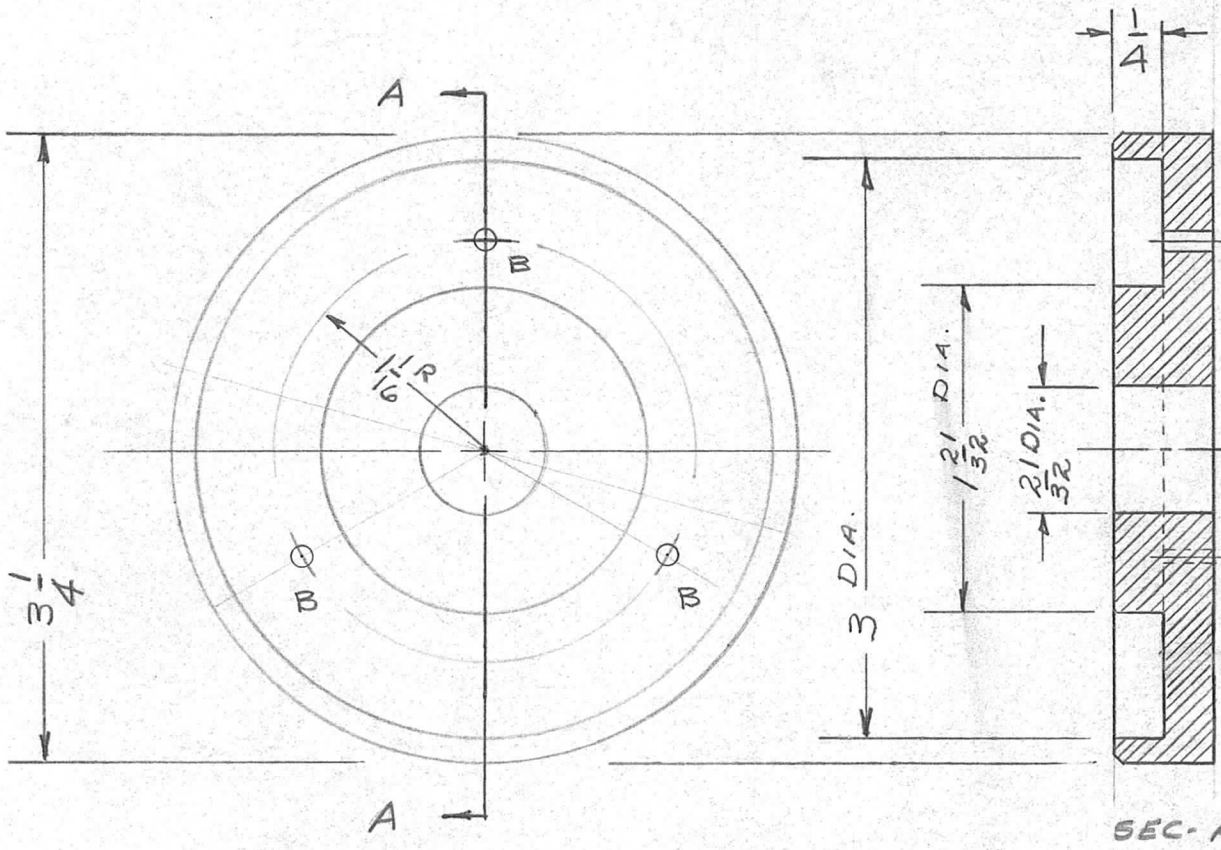

NOTICE TO PERSONS RECEIVING THIS DRAWING

THE TECHNICAL MATERIEL CORPORATION claims proprietary right in the material disclosed hereon. This drawing is issued in confidence for engineering information only and may not be reproduced or used to manufacture anything shown hereon without permission from THE TECHNICAL MATERIEL CORPORATION to the user. This drawing is loaned for mutual assistance and is subject to recall at any time.

Property of:
THE TECHNICAL MATERIEL CORPORATION
MAMARONECK, NEW YORK

SEC-A-A

								REQ. ITEM	PART NO.	DESCRIPTION			SYMBOL				
								1/2 THICK		THE TECHNICAL MATERIEL CORP.							
								STOCK SIZE		MAMARONECK, NEW YORK							
								SILICONE		SPACER, CORE, ANT. TUNER							
								MATERIAL									
								G-7	CR	arc		Jide		OMP			
								TYPE & TEMPER		HEAT TREAT. SPEC.		DRAWN		CHECKED		FINAL APPROVAL	
								CR				S.G.					
								FINISH & SPEC. NO.		ELEC. DES. APP		MECH. DES. APP		PX-479		A	
ISSUE		ITEM	CHANGED FROM	DATE	CH. NO.	DRAFTS	CHECKER	ENG. APP.									
A		1	MATL. WAS MELAMINE	10-24-62	7526	2	Jide	OMP									
TOLERANCES				SCALE:													
DEC. DIM. ±				MAXIMUM ALLOWABLE TOLERANCES HAVE BEEN DETERMINED AND ANY DEVIATIONS WILL BE CAUSE FOR REJECTION.													
FRAC. DIM. ± 1/64				REMOVE ALL BURRS AND SHARP EDGES													
ANGULAR DIM. ±																	