

IF IT IS FOUND DESIRABLE TO CHANGE ANY TOLERANCE OR OTHER DETAIL SPECIFIED ON THIS DRAWING NOTIFY THE PURCHASER PROMPTLY.

PX-264 D

MAXIMUM ALLOWABLE TOLERANCES HAVE BEEN DETERMINED AND DEVIATIONS WILL BE CAUSE FOR REJECTION. REMOVE ALL BURRS AND SHARP EDGES

REQ. PER UNIT	USED ON			
	MODEL	PROJECT NO.	ASS'Y. NO.	DATE
2	GPR	297		3-7-55
1	SBE-1-2			7-24-57
1	SBE-3	AP-101		11-30-58

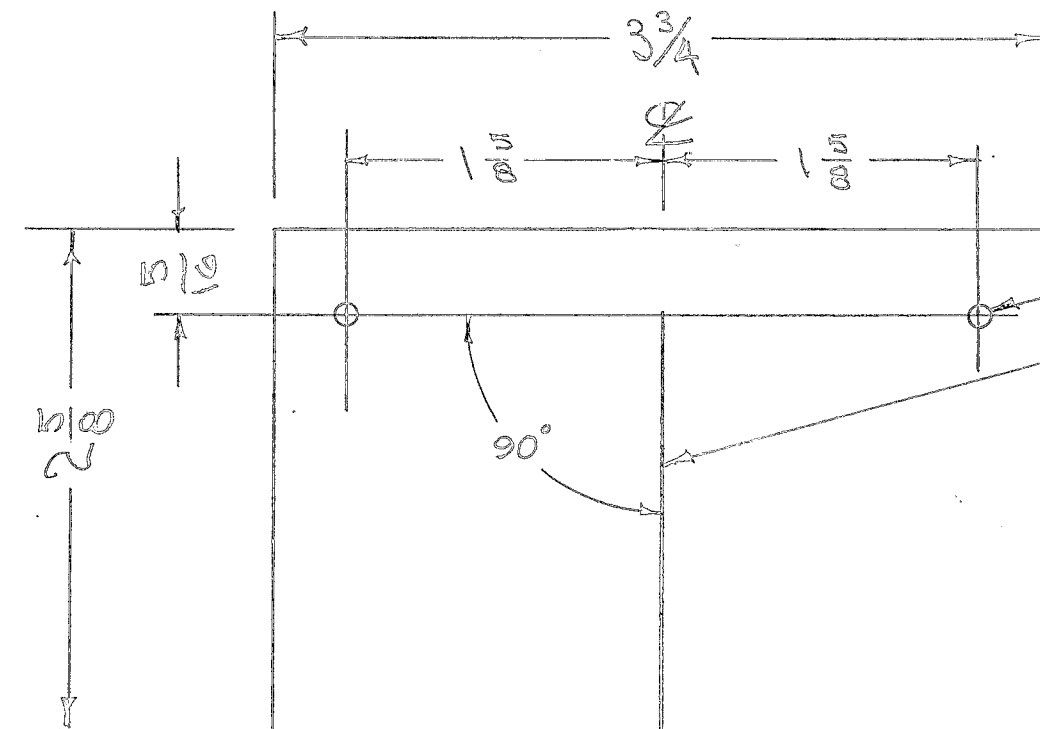

REQ.	ITEM	PART NO.	DESCRIPTION	SYMBOL
		.040 ± .015	THE TECHNICAL MATERIEL CORP.	
		STOCK SIZE	MAMARONECK, NEW YORK	
		PLEXIGLASS. —H—	DIAL FIDUCIARY	
		MATERIAL	G.P.R.	
		WEIGHT PER PC.		
		TYPE & TEMPER	CD. 87-95	###
		DRAWN	ELEC. DES. APP.	MECH. DES. APP.
		HEAT TREAT. SPEC.	G.T.O	
		FINISH & SPEC. NO.	CHECKED	FINAL APPROVAL
				PX-264 D

ISSUE	ITEM	CHANGED FROM	DATE	CN. NO.	DRAFTS	CHECKER	ENG. APP.
D	1	Stock Size Tol. Added	1/28/52	4	J.M.C.		
C	1	3/16 WAS 5/64	6/5/56	3	J.M.C.	C.S.P.	
B	1	HOLES WERE #32 DRILL	8/2/55	2	J.M.C.	J.M.C.	
A	1	90° ANGLE ADDED					
		5/16 WAS 7/16	6/1/51	1	J.M.C.	J.M.C.	

TOLERANCES		SCALE
ALL OTHERS	DEC. DIM. ± FRAC. DIM. ± 1/64 ANGULAR DIM. ± 1/2°	DRILL, PUNCH, COMMERCIAL STOCK SIZES AND MANUFACTURERS TOLERANCES ARE NOT INCLUDED.