

IF IT IS FOUND DESIRABLE TO CHANGE ANY TOLERANCE OR OTHER DETAIL SPECIFIED ON THIS DRAWING NOTIFY THE PURCHASER PROMPTLY.

PX-224 A

MAXIMUM ALLOWABLE TOLERANCES HAVE BEEN DETERMINED AND DEVIATIONS WILL BE CAUSE FOR REJECTION. REMOVE ALL BURRS AND SHARP EDGES

USED ON

AMT. PER UNIT	MODEL	PROJECT NO.	ASSY. NO.	DATE
SEE NOTE	TAC-1	132	A-787	1-28-54

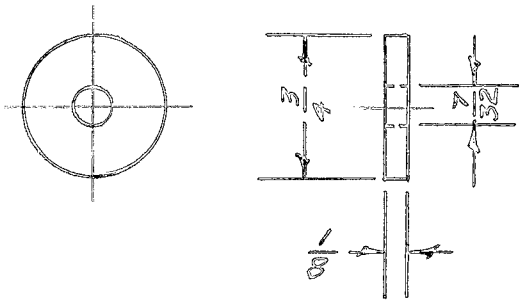

PX-224-1
4 PER UNIT

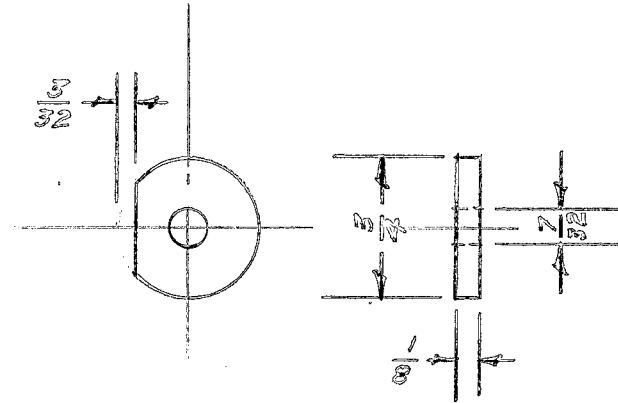

PX-224-2
4 PER UNIT

REQ.	ITEM	PART NO.	DESCRIPTION	SYMBOL
		5/16" D.	THE TECHNICAL MATERIEL CORP. MAMARONECK, NEW YORK	
		STOCK SIZE		
		TEFLON	WASHER, CONDENSOR SUPPORT	
		MATERIAL	WEIGHT PER PC.	
			TAC-1	
		TYPE & TEMPER	16	amb
			DRAWN	W.E.
			ELEC. DES. APP.	
			MECH. DES. APP.	
		HEAT TREAT. SPEC.	checked	
			CHECKED	
		FINISH & SPEC. NO.		
			FINAL APPROVAL	
			PX-224	A

A	1	PX-224-2 ADDED	1/15/54	1	15	J.A.D.	W.D.E.
ISSUE	ITEM	CHANGED FROM	DATE	CN. NO.	DRAFTS	CHECKER	ENG. APP.

TOLERANCES			SCALE FULL				
ALL OTHERS	DEC. DIM. ±	FRAC. DIM. ±	DRILL, PUNCH, COMMERCIAL STOCK SIZES AND MANUFACTURERS TOLERANCES ARE NOT INCLUDED.				
	ANGULAR DIM. ±						