

IF IT IS FOUND DESIRABLE TO CHANGE ANY TOLERANCE OR OTHER DETAIL SPECIFIED ON THIS DRAWING NOTIFY THE PURCHASER PROMPTLY.

PX-197

B

MAXIMUM ALLOWABLE TOLERANCES HAVE BEEN DETERMINED AND DEVIATIONS WILL BE CAUSE FOR REJECTION. REMOVE ALL BURRS AND SHARP EDGES

USED ON				
AMT PER UNIT	MODEL	PROJECT NO.	ASS'Y. NO.	DATE
2	TAC-1	132	A-646	2-28-54

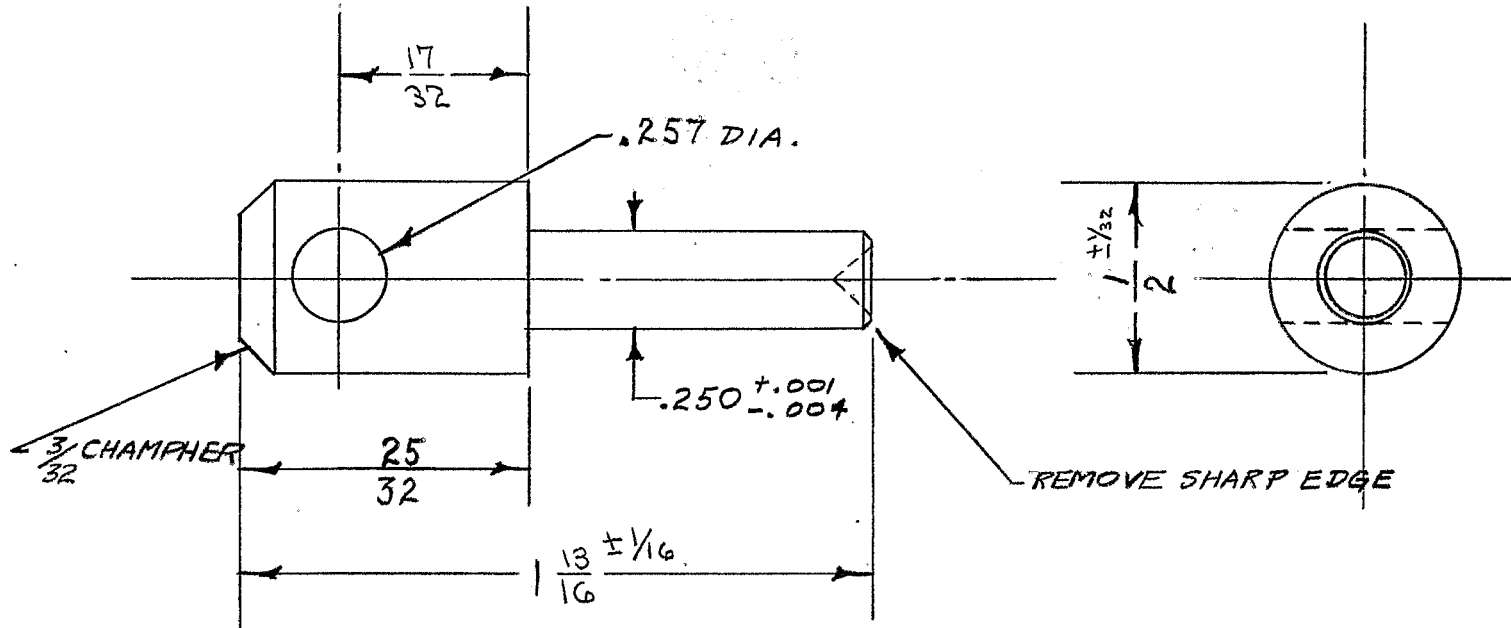

\* FUNGUS PROOFING PER TMC SPECIFICATION S-113

REQ.	ITEM	PART NO.	DESCRIPTION	SYMBOL
		1/2 D. ROD	THE TECHNICAL MATERIEL CORP.	
		STOCK SIZE	MAMARONECK, NEW YORK	
		PHENOLIC	CONNECTING ROD	
		MATERIAL	TAC-1	
		WEIGHT PER PC.		
		LINEN BASE	15 12-16-53	
		TYPE & TEMPER	ARB	WDC
		HEAT TREAT. SPEC.	DRAWN	ELEC. DES. APP.
		FINISH & SPEC. NO.	MECH. DES. APP.	
			CHECKED	FINAL APPROVAL
				PX-197
				B

ISSUE	ITEM	CHANGED FROM	DATE	CN. NO.	DRAFTS	CHECKER	ENG. APP.
B		S113 ADDED	4/13/64	11186	A.M.	Hale	WDC
A	2	17/32 WAS 1/2	3/10/54	W.D.C.	C.D.D.	B.B.	WDC
	1	25/32 WAS 3/4					

TOLERANCES		SCALE
ALL OTHERS	DEC. DIM. ± FRAC. DIM. ± 1/64 ANGULAR DIM. ±	1/16

DRILL, PUNCH, COMMERCIAL STOCK SIZES AND MANUFACTURERS TOLERANCES ARE NOT INCLUDED.