

APPLICATION			REVISIONS						
QTY	MODEL USED ON	ASS'Y NO.	LTR	DESCRIPTION	DATE	E.M.N.NO	DRAFT	CHKD	APPD
3	A'W 101-4	AX 5263	Ø	ORIGINAL RELEASE	1-3-99		GDL		

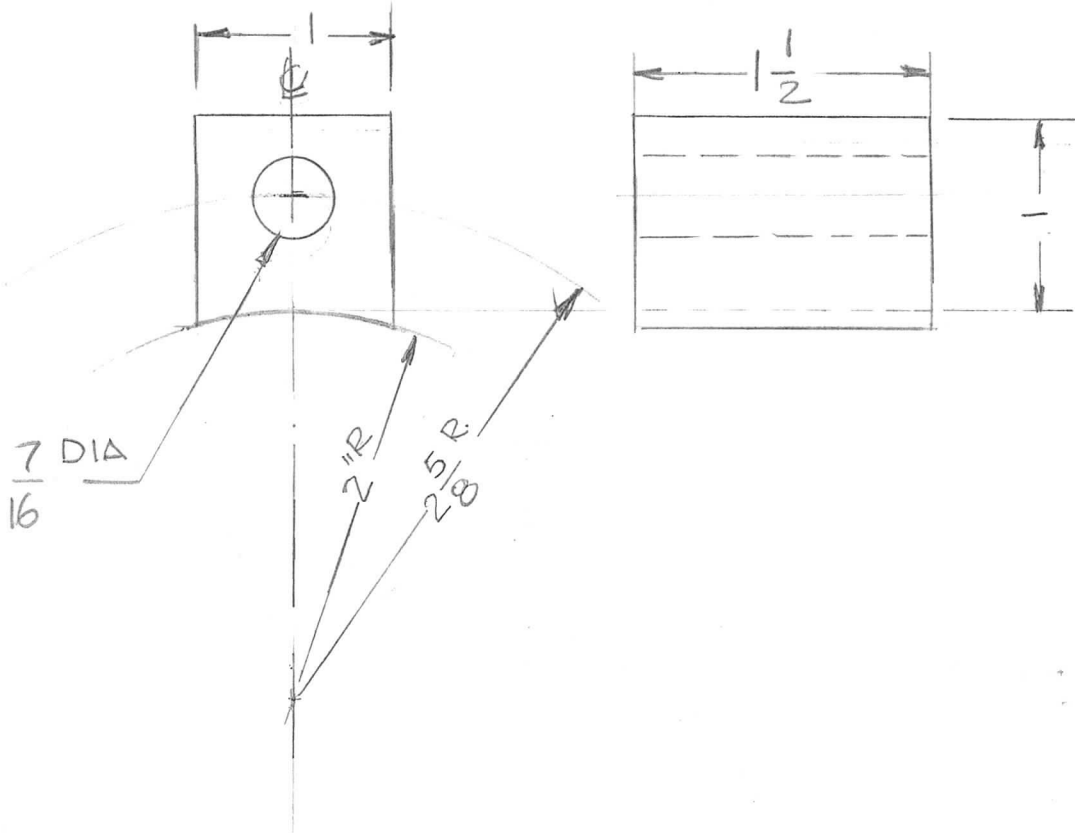

UNLESS OTHERWISE SPECIFIED DIMENSIONS ARE IN INCHES AND INCLUDE CHEMICALLY APPLIED OR PLATED FINISHES		REQ'D	ITEM	PART NUMBER	DESCRIPTION	SYM.
DECIMALS: .X ± .05, .XX ± .01, .XXX ± .005 FRACTIONS: 1/64 TOLS.: ANGLES 0° -30'		LIST OF MATERIAL				
MATERIAL 1x1x1/2 COLD ROLL STEEL		FINAL APPROVAL <i>JCB</i>		THE TECHNICAL MATERIEL CORP.		
FINISH NICKEL PLATE		MECH. DES.		MAMARONECK, NEW YORK		
		ELECT. DES.		SUPPORT, BASE		
		CHECKED				
		DRAWN <i>GDL</i>		DATE 8-22-88		

NOTICE TO PERSONS RECEIVING THIS DRAWING THE TECHNICAL MATERIEL CORPORATION claims proprietary right in the material disclosed hereon. This drawing is issued in confidence for engineering information only and may not be reproduced or used to manufacture anything shown hereon without permission from THE TECHNICAL MATERIEL CORPORATION to the user. This drawing is loaned for mutual assistance and is subject to recall at any time.				SIZE A	CODE IDENT. NO. 82679	DWG NO. PO 351	ISSUE Ø
SCALE 1:1		SHEET		OF			