

THE CONTENTS OF THIS DRAWING ARE THE EXCLUSIVE PROPERTY OF THE TECHNICAL MATERIEL CORP. ITS UNAUTHORIZED USE OR REPRODUCTION IN WHOLE OR IN PART IS STRICTLY FORBIDDEN.

REQ. PER UNIT

AX-354

USED ON

MODEL

ASS'Y. NO.

DATE

6-12-62

PO-246

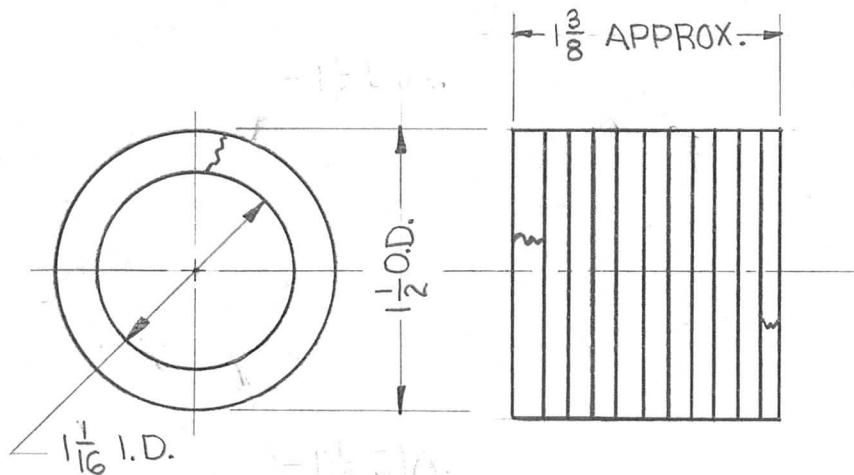

REQ.	ITEM	PART NO.	PRITCHARD DESCRIPTION		SYMBOL	
		7/32	THE TECHNICAL MATERIEL CORP.			
		STOCK SIZE	MAMARONECK, NEW YORK			
		FLAX.	PACKING,			
		MATERIAL	STUFFING TUBE			
SYM	DESCRIPTION	DATE	CH. NO.	DRAFTS	CHECKER	ENG. APP.
UNLESS OTHERWISE SPECIFIED: DIMENSIONS ARE IN INCHES TOLERANCES ON FRAC. ± 1/64 DEC. ± .005 ANGLES ± 1/2°		SCALE: DO NOT SCALE				
		MAXIMUM ALLOWABLE TOLERANCES HAVE BEEN DETERMINED AND ANY DEVIATIONS WILL BE CAUSE FOR REJECTION. REMOVE ALL BURRS AND SHARP EDGES				
		TYPE & TEMPER	HEAT TREAT. SPEC.	DRAWN	CHECKED	FINAL APPROVAL
				R. Lanchin	J. We	BF
		FINISH & SPEC. NO.	ELEC. DES. APP.	MECH. DES. APP.	PO-246	