

IF IT IS FOUND DESIRABLE TO CHANGE ANY TOLERANCE OR OTHER DETAIL SPECIFIED ON THIS DRAWING NOTIFY THE PURCHASER PROMPTLY.

PO-122

MAXIMUM ALLOWABLE TOLERANCES HAVE BEEN DETERMINED AND DEVIATIONS WILL BE CAUSE FOR REJECTION. REMOVE ALL BURRS AND SHARP EDGES

REQ. PER UNIT

USED ON

REQ. PER UNIT	MODEL	PROJECT NO.	ASS'Y. NO.	DATE
1	KS-85-X	J-227		8-21-53

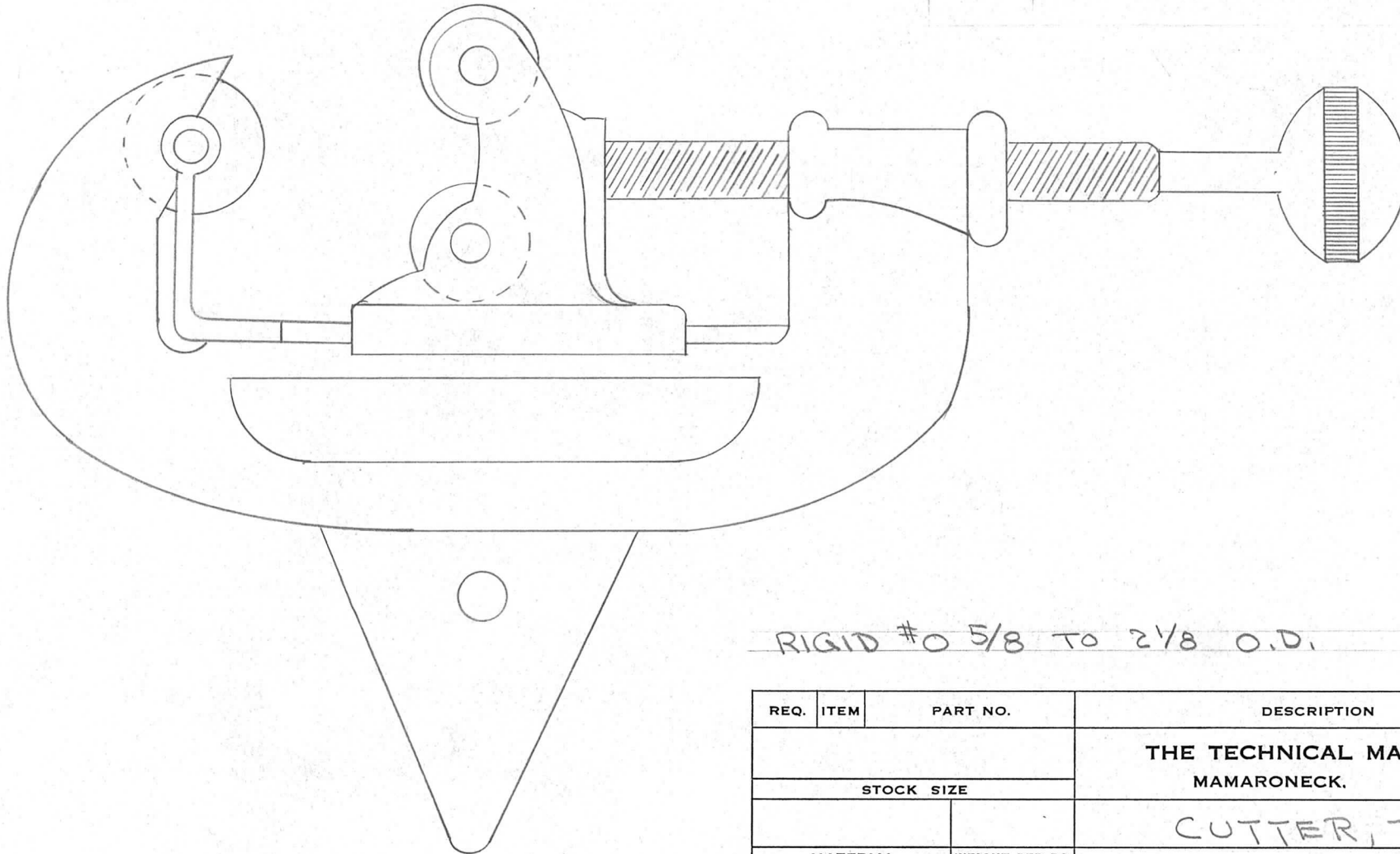

RIGID #0 5/8 TO 2 1/8 O.D.

REQ.	ITEM	PART NO.	DESCRIPTION	SYMBOL
			THE TECHNICAL MATERIEL CORP. MAMARONECK. NEW YORK	
STOCK SIZE			CUTTER, TUBING	
MATERIAL		WEIGHT PER PC.		
TYPE & TEMPER			<i>AKC</i>	
			DRAWN	MECH. DES. APP.
HEAT TREAT. SPEC.			<i>AKC</i>	
			CHECKED	FINAL APPROVAL
FINISH & SPEC. NO.			<i>AKC</i>	

ISSUE	ITEM	CHANGED FROM	DATE	CN. NO.	DRAFTS	CHECKER	ENG. APP.

TOLERANCES

SCALE

ALL OTHERS

DEC. DIM. ±
FRAC. DIM. ±
ANGULAR DIM. ±

DRILL, PUNCH, COMMERCIAL STOCK SIZES AND MANUFACTURERS TOLERANCES ARE NOT INCLUDED.

PO-122