

IF IT IS FOUND DESIRABLE TO CHANGE ANY TOLERANCE OR OTHER DETAIL SPECIFIED ON THIS DRAWING NOTIFY THE PURCHASER PROMPTLY.

MAXIMUM ALLOWABLE TOLERANCES HAVE BEEN DETERMINED AND DEVIATIONS WILL BE CAUSE FOR REJECTION. REMOVE ALL BURRS AND SHARP EDGES

PO-108

USED ON

MODEL	PROJECT NO.	ASS'Y. NO.	DATE
AMC-6	190		4-15-16

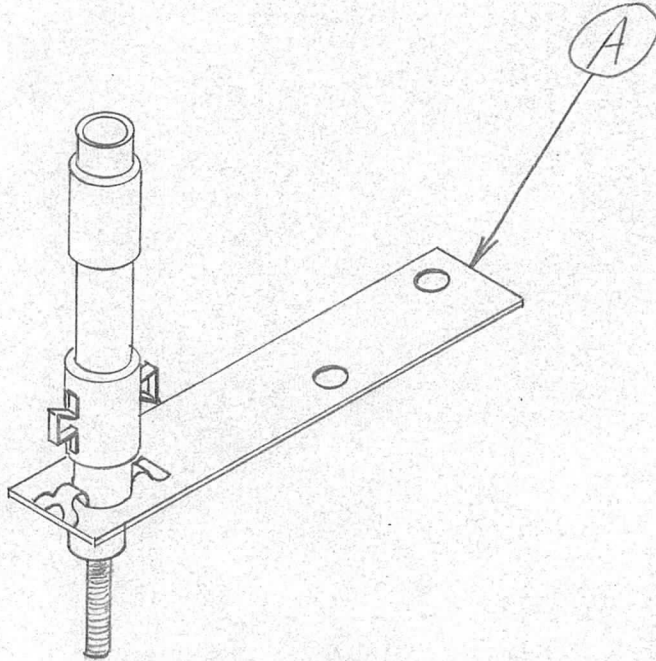

NOTE :

SUPPLIED AS TWO PARTS WITH MOUNTING BRACKET "A"

REF: GRAY BURNE CORP. VARI LOOP STICK

REQ.	ITEM	PART NO.	DESCRIPTION	SYMBOL
			THE TECHNICAL MATERIEL CORP. MAMARONECK, NEW YORK	
		STOCK SIZE	INDUCTOR VARIABLE	
		MATERIAL	WITH BRACKET	
		WEIGHT PER PC.		
		TYPE & TEMPER	4-15-53	
		HEAT TREAT. SPEC.	DRAWN	ELEC. DES. APP. MECH. DES. APP.
		FINISH & SPEC. NO.	CHECKED	FINAL APPROVAL
				PO-108

ISSUE	ITEM	CHANGED FROM	DATE	CN. NO.	DRAFTS	CHECKER	ENG. APP.
TOLERANCES			SCALE				
ALL OTHERS	DEC. DIM. ± FRAC. DIM. ± ANGULAR DIM. ±	DRILL, PUNCH, COMMERCIAL STOCK SIZES AND MANUFACTURERS TOLERANCES ARE NOT INCLUDED.					