

| REQ. PER UNIT | USED ON | | |
|---------------|-------------------|------------|---------|
| | MODEL | ASS'Y. NO. | DATE |
| 4 | GPT-200K (AX-395) | A-2821 | 9-10-63 |
| 3 | GPT-200K (AX-395) | A-2822 | 9-10-63 |
| 3 | GPT-200K (AX-395) | A-2823 | 9-10-63 |

PM-984 ~~Ø~~

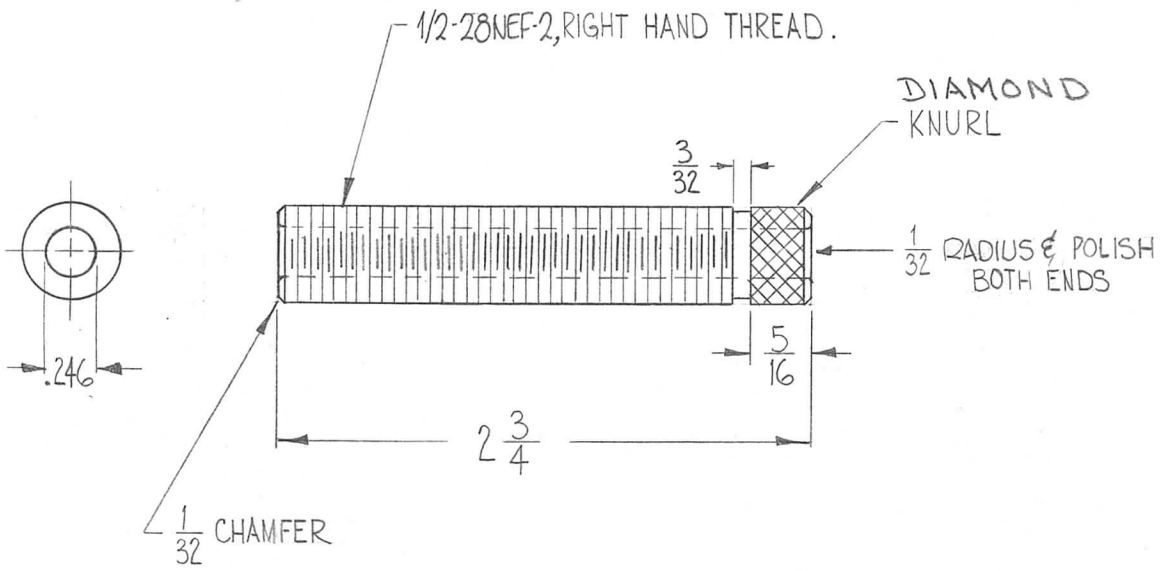

| REQ. | ITEM | PART NO. | F. BUDETTI | DESCRIPTION | SYMBOL | | | | | | |
|---|---------------------------------|---|------------|--|---------|-----------|--------------------|-------------------|-----------------|---------|----------------|
| | | 1/2 THK. | | THE TECHNICAL MATERIEL CORP. MAMARONECK. NEW YORK | Ø | | | | | | |
| | | STAINLESS STEEL | | | | | | | | | |
| Ø | ORIGINAL RELEASE FOR PRODUCTION | 3/23/64 | | ROD, THREADED | | | | | | | |
| SYM | DESCRIPTION | DATE | CH. NO. | DRAFTS | CHECKER | ENG. APP. | MATERIAL | | | | |
| UNLESS OTHERWISE SPECIFIED DIMENSIONS ARE IN INCHES AND INCLUDE CHEMICALLY APPLIED OR PLATED FINISHES | | SCALE | 1" = 1" | | | | (NON MAGNETIC) | W.A. FRANCO | QAQB | Rode | 3/23/64 |
| DECIMALS .X ± .05 .XX ± .01 .XXX ± .005 | TOLERANCES | FRACTIONS ± 1/64 ANGLES ± 0° 30' | CODE | A | | | TYPE & TEMPER | HEAT TREAT. SPEC. | DRAWN | CHECKED | FINAL APPROVAL |
| | | | | | | | S104 PASSIVATE | | 2B RB | BC | PM-984 |
| | | | | | | | FINISH & SPEC. NO. | ELEC. DES. APP. | MECH. DES. APP. | | Ø |