

THE CONTENTS OF THIS DRAWING ARE THE EXCLUSIVE PROPERTY OF THE TECHNICAL MATERIEL CORP. ITS UNAUTHORIZED USE FOR REPRODUCTION IN WHOLE OR IN PART IS STRICTLY FORBIDDEN.

|               |                   |            |         |        |   |
|---------------|-------------------|------------|---------|--------|---|
| REQ. PER UNIT | USED ON           |            |         | PM-864 | 0 |
|               | MODEL             | ASS'Y. NO. | DATE    |        |   |
| 1             | GPT-200K (AS-123) | A-2681     | 5-23-63 |        |   |

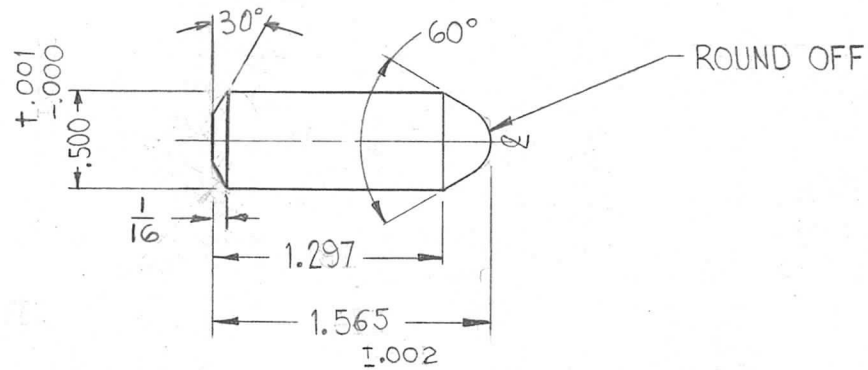

|   |             |   |         |                     |         |           |           |                    |  |                 |                |  |
|---|-------------|---|---------|---------------------|---------|-----------|-----------|--------------------|--|-----------------|----------------|--|
|   |             |   |         |                     |         |           | REQ. ITEM | PART NO.           | F. BUDETTI   | DESCRIPTION     | SYMBOL         |  |
|   |             |   |         |                     |         |           |           | 1/2 DIA.           | THE TECHNICAL MATERIEL CORP.<br>MAMARONECK, NEW YORK |                 |                |  |
|   |             |   |         |                     |         |           |           | STAINLESS STEEL    | SHAFT, DETENT  |                 |                |  |
|   |             |   |         |                     |         |           |           | MATERIAL           |  |                 |                |  |
| ○ ORIGINAL RELEASE FOR PRODUCTION   | 3-6-64      |   |         |                     |         |           |           | 303                | W.A. FRANCO  | aa              | RAC 4-7-64     |  |
| SYM   | DESCRIPTION | DATE                                      | CH. NO. | DRAFTS              | CHECKER | ENG. APP. |           |                    |  |                 |                |  |
| UNLESS OTHERWISE SPECIFIED<br>DIMENSIONS ARE IN INCHES AND INCLUDE<br>CHEMICALLY APPLIED OR PLATED FINISHES |             | SCALE                                     |         | FULL (DO NOT SCALE) |         |           |           |                    |  |                 |                |  |
| DECIMALS<br>.X ± .05<br>.XX ± .01<br>.XXX ± .005  | TOLERANCES  | FRACTIONS<br>± 1/64<br>ANGLES<br>± 0° 30' | CODE    | A                   |         |           |           |                    |  |                 |                |  |
|   |             |   |         |                     |         |           |           | S104-PASSIVATE     | DRWN   | CHECKED         | FINAL APPROVAL |  |
|   |             |   |         |                     |         |           |           | FINISH & SPEC. NO. | ELEC. DES. APP.                                      | MECH. DES. APP. | PM-864 0       |  |