

THE CONTENTS OF THIS DRAWING ARE THE EXCLUSIVE PROPERTY OF THE TECHNICAL MATERIEL CORP. ITS UNAUTHORIZED USE FOR REPRODUCTION IN WHOLE OR IN PART IS STRICTLY FORBIDDEN.

REQ. PER UNIT	USED ON			PM-836	B
	MODEL	ASS'Y. NO.	DATE		
1	TU-2		4-2-63		

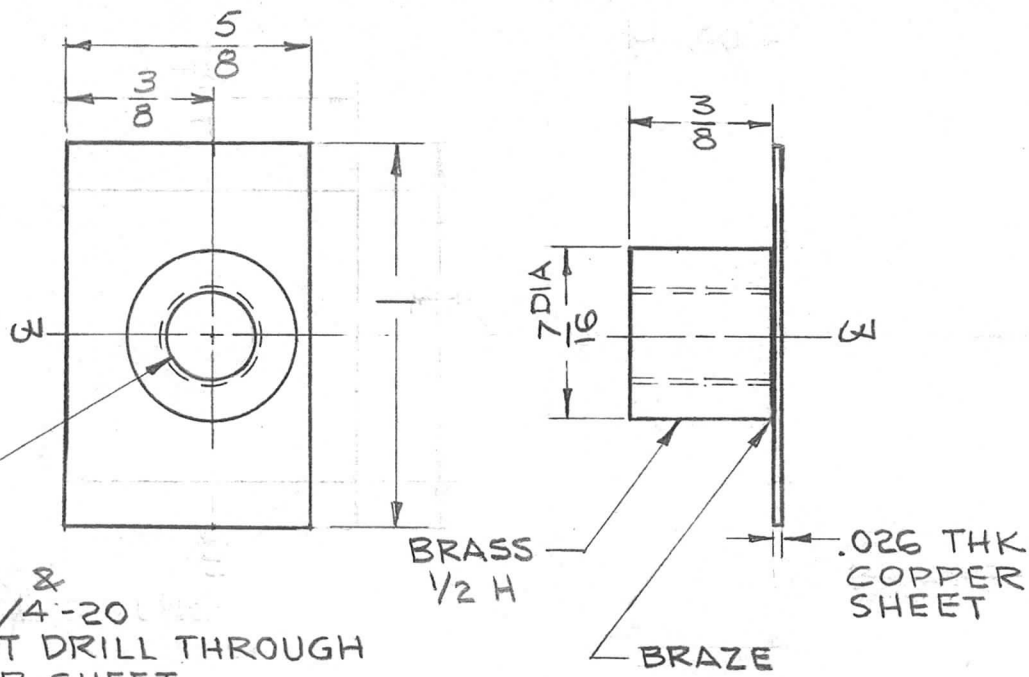

DRILL & TAP 1/4-20
DO NOT DRILL THROUGH
COPPER SHEET

REQ.	ITEM	PART NO.	PRITCHARD DESCRIPTION				SYMBOL
		SEE PICTORIAL STOCK SIZE	THE TECHNICAL MATERIEL CORP. MAMARONECK, NEW YORK				
B	ADDED 3/8 DIM & 5/8 WAS 3/4 DELE. REF: PM 836	5.1.68	18903	HS	EFM		
A	1" WAS 3/4	2.23.66	15836	HLA	MM		
SYM	DESCRIPTION	DATE	CH. NO.	DRAFTS	CHECKER	ENG. APP.	
UNLESS OTHERWISE SPECIFIED DIMENSIONS ARE IN INCHES AND INCLUDE CHEMICALLY APPLIED OR PLATED FINISHES		SCALE					
DECIMALS .X ± .05 .XX ± .01 .XXX ± .005		TOLERANCES		FRACTIONS ± 1/64 ANGLES ± 0° 30'		CODE	
				TYPE & TEMPER		HEAT TREAT. SPEC.	
				DRAWN		CHECKED	
				FINISH & SPEC. NO.		ELEC. DES. APP.	
				DRAWN		CHECKED	
				FINAL APPROVAL			
				PM-836		B	